

# CONCRETE TECHNOLOGY LAB MANUAL

DEPARTMENT OF CIVIL ENGINEERING



**MARRI LAXMAN REDDY**  
**INSTITUTE OF TECHNOLOGY AND MANAGEMENT**

(AN AUTONOMOUS INSTITUTION)

(Approved by AICTE, New Delhi & Affiliated to JNTUH, Hyderabad)

Accredited by NBA and NAAC with 'A' Grade & Recognized Under Section 2(f) & 12(B) of the UGC act, 1956

2022-2023



**MARRI LAXMAN REDDY**  
**INSTITUTE OF TECHNOLOGY AND MANAGEMENT**

(AN AUTONOMOUS INSTITUTION)

(Approved by AICTE, New Delhi & Affiliated to JNTUH, Hyderabad)

Accredited by NBA and NAAC with 'A' Grade & Recognized Under Section 2(f) & 12(B) of the UGC act, 1956

## **CERTIFICATE**

This is to certify that this manual is a bonafide record of practical work in the **Concrete Technology Lab in First Semester of Third year B. Tech (Civil) programme** during the academic year **2022-23**. The book is prepared by **Ms. Nanditha Mandava, Mr. B. Mahender, Assistant Professor, Department of Civil Engineering.**

Signature of HOD

Signature of Dean Academics

Signature of Principal

## INDEX

<u>S. No</u>	<u>CONTENT</u>	<u>PAGE NO</u>
1	PREFACE	i
2	ACKNOWLEDGEMENT	ii
3	GENERAL INSTRUCTIONS	iii
4	SAFETY PRECAUTIONS	iv
5	INSTITUTE VISION AND MISSION	v
6	DEPARTMENT VISION AND MISSION	vi
7	PROGRAMME EDUCATIONAL OBJECTIVES	vi
8	PROGRAM SPECIFIC OUTCOMES	vi
9	PROGRAMME OUTCOMES	vii - viii
10	COURSE STRUCTURE, OBJECTIVES AND OUTCOMES	ix – x
11	TESTS ON CEMENT	1
12	NORMAL CONSISTENCY OF CEMENT	2 – 3
13	FINENESS OF CEMENT	3 – 5
14	INITIAL AND FINAL SETTING TIME OF CEMENT	6 – 9
15	SPECIFIC GRAVITY OF CEMENT	10 – 12
16	SOUNDNESS OF CEMENT	13 – 15
17	COMPRESSIVE STRENGTH OF CEMENT	16 - 19
18	TESTS ON AGGREGATE	20
19	SIEVE ANALYSIS AND GRADATION ZONE	21 – 25
20	BULKING OF SAND	26 – 28
21	BULKING OF SAND, BULK AND COMPACT DENSITIES OF FINE & COARSE AGGREGATE	29 - 32
22	TESTS ON FRSH CONCRETE	33
23	SLUMP TEST	34 – 37

## INDEX

24	COMPACTION FACTOR STRESS	38 – 41
25	VEE – BEE TEST	42 – 45
26	FLOW TABLE TEST	46 – 48
<b>27</b>	<b>TESTS ON SELF-COMPACTING CONCRETE</b>	<b>49</b>
28	SLUMP CONE	50 – 52
29	V FUNNEL	53 – 55
30	L BOX	56 – 58
<b>31</b>	<b>TESTS ON HARDENED CONCRETE</b>	<b>59</b>
32	COMPRESSION TEST ON CUBES AND CYLINDERS	60 – 65
33	FLEXURE TEST	66 – 69
34	SPLITTING TENSILE TEST	70 – 72
35	MODULUS OF ELASTICITY	73 – 75
<b>36</b>	<b>NON-DESTRUCTIVE TEST OF CONCRETE</b>	<b>76</b>
37	REBOUND HAMMER	77 – 80
38	ULTRA SONIC PULSE VELOCITY	81 – 83

## **PREFACE**

This book entitled “Concrete Technology Lab Manual” is intended for the use of fifth semester (i.e., III - I) B. Tech (civil) students of Marri Laxman Reddy Institute of Technology and Management, Dundigal, Hyderabad. The main objective of the Concrete Technology Lab Manual is to teach the student basic concrete fundamentals in various civil engineering applications. This book lays foundation of certain basic concepts and skills that can be repeatedly employed by the students in their future endeavours. The main aim of this book is to develop the habit of scientific reasoning and providing answers to all the doubts that arise during the course of conducting experiments. The book was written as per the new syllabus prescribed by the JNTUH university in a simple language. Some of the additional experiments apart from the syllabus also included in the book. These experiments will help the students to expertise in the analysis and reporting the water quality for drinking purpose. Hence, we hope this book serve for better understanding by the student community with all details of experiments

By,  
Ms. Nanditha Mandava

Mr. B. Mahender  
Asst Professor, Department of civil engineering

## ACKNOWLEDGEMENT

It was really a good experience, working at Highway Engineering & Concrete Technology Lab. First, I would like to thank Mr. B. Mahender, Asst. Professor, Department of Civil Engineering, Marri Laxman Reddy Institute of technology & Management for giving the technical support in preparing the document.

I express my sincere thanks to Mr. K. Murali, Head of the Department of Civil Engineering, Marri Laxman Reddy Institute of technology & Management, for his concern towards me and gave me opportunity to prepare Concrete Technology laboratory manual.

I am deeply indebted and gratefully acknowledge the constant support and valuable patronage of Dr. Balarengadurai Chinnaiah, Dean Academics, Marri Laxman Reddy Institute of technology & Management. I am unboundedly grateful to him for timely corrections and scholarly guidance.

I express my hearty thanks to Dr. K. Venkateswara Reddy, Principal, Marri Laxman Reddy Institute of technology & Management, for giving me this wonderful opportunity for preparing the Concrete Technology laboratory manual.

At last, but not the least I would like to thank the entire Civil Department faculties those who had inspired and helped me to achieve my goal.

By,  
Ms. Nanditha Mandava

Mr.B. Mahender  
Asst Professor, Department of civil engineering

## **GENERAL INSTRUCTIONS**

1. Students are instructed to come to Concrete Technology laboratory on time. Late comers are not entertained in the lab.
2. Students should be punctual to the lab. If not, conducted experiments will not be repeated.
3. Students are expected to come prepared at home with the experiments which are going to performed.
4. Students are instructed to display their identity cards and apron before entering into the lab.
5. Students are instructed not to bring mobile phones to the lab.
6. The equipment's and other accessories used in Concrete Technology lab should be handled with care and responsibility.
7. Any damage to the equipment's during the lab session is student's responsibility and penalty or fine will be collected from the student.
8. Students should update the records and lab observation books session wise. Before leaving the lab, the student should get his lab observation book signed by the faculty.
9. Students should submit the lab records 2/3 days in advance to the concerned faculty members in the staffroom for their correction and return.
10. Students should not move around the lab during the lab session.
11. If any emergency arises, the student should take the permission from faculty member concerned in written format.
12. The faculty members may suspend any student from the lab session on disciplinary grounds.

## **SAFETY PRECAUTIONS**

1. While working in the laboratory suitable precautions should be observed to prevent accidents.
2. Always follow the experimental instructions strictly.
3. Use the first aid box in case of any accident/mishap.
4. Never work in the laboratory unless a demonstrator or teaching assistant is present.
5. When the experiment is completed, students should disconnect the setup made by them, and should return all the components/instruments taken for the purpose.



# **INSTITUTION VISION AND MISSION**

## **VISION**

To establish as an ideal academic institution in the service of the nation, the world and the humanity by graduating talented engineers to be ethically strong, globally competent by conducting high quality research, developing breakthrough technologies, and disseminating and preserving technical knowledge.

## **OUR MISSION**

To fulfil the promised vision through the following strategic characteristics and aspirations:

- Contemporary and rigorous educational experiences that develop the engineers and managers.
- An atmosphere that facilitates personal commitment to the educational success of students in an environment that values diversity and community.
- Prudent and accountable resource management.
- Undergraduate programs that integrate global awareness, communication skills and team building.
- Leadership and service to meet society's needs
- Education and research partnerships with colleges, universities, and industries to graduate
- Education and training that prepares students for interdisciplinary engineering research and advanced problem-solving abilities.
- Highly successful alumni who contribute to the profession in the global society.

**DEPARTMENT VISION, MISSION, PROGRAMME EDUCATIONAL OBJECTIVES  
AND SPECIFIC OUTCOMES**

**VISION**

The Civil Engineering department strives to impart quality education by extracting the innovative skills of students and to face the challenges in latest technological advancements and to serve the society.

**MISSION**

Provide quality education and to motivate students towards professionalism

Address the advanced technologies in research and industrial issues

**PROGRAMME EDUCATIONAL OBJECTIVES**

The Programme Educational Objectives (PEOs) that are formulated for the civil engineering programme are listed below;

**PEO-I** solving civil engineering problems in different circumstances

**PEO-II** Pursue higher education and research for professional development.

**PEO-III** Inculcate qualities of leadership for technology innovation and entrepreneurship.

**PROGRAM SPECIFIC OUTCOMES**

**PSO 1 - UNDERSTANDING:** Graduates will have ability to describe, analyse and solve problems using mathematical, scientific, and engineering knowledge.

**PSO 2 - ANALYTICAL SKILLS:** Graduates will have an ability to plan, execute, maintain, manage, and rehabilitate civil engineering systems and processes.

**PSO 3 - EXECUTIVE SKILLS:** Graduates will have an ability to interact and work effectively in multi disciplinary teams.

## **PROGRAMME OUT COMES**

1. **Engineering knowledge:** Apply the knowledge of mathematics, science, engineering fundamentals, and an engineering specialization to the solution of complex engineering problems.
2. **Problem analysis:** Identify, formulate, review research literature, and analyze complex engineering problems reaching substantiated conclusions using first principles of mathematics, natural sciences, and engineering sciences.
3. **Design/development of solutions:** Design solutions for complex engineering problems and design system components or processes that meet the specified needs with appropriate consideration for the public health and safety, and the cultural, societal, and environmental considerations.
4. **Conduct investigations of complex problems:** Use research-based knowledge and research methods including design of experiments, analysis and interpretation of data, and synthesis of the information to provide valid conclusions.
5. **Modern tool usage:** Create, select, and apply appropriate techniques, resources, and modern engineering and IT tools including prediction and modeling to complex engineering activities with an understanding of the limitations.
6. **The engineer and society:** Apply reasoning informed by the contextual knowledge to assess societal, health, safety, legal and cultural issues and the consequent responsibilities relevant to the professional engineering practice.
7. **Environment and sustainability:** Understand the impact of the professional engineering solutions in societal and environmental contexts, and demonstrate the knowledge of, and need for sustainable development.
8. **Ethics:** Apply ethical principles and commit to professional ethics and responsibilities and norms of the engineering practice.
9. **Individual and team work:** Function effectively as an individual, and as a member or leader in diverse teams, and in multidisciplinary settings.
10. **Communication:** Communicate effectively on complex engineering activities with the engineering community and with society at large, such as, being able to comprehend and write effective reports and design documentation, make effective presentations, and give and receive clear instructions.
11. **Project management and finance:** Demonstrate knowledge and understanding of the engineering and management principles and apply these to one's own work, as a member and leader in a team, to manage projects and in multidisciplinary environments.
12. **Life-long learning:** Recognize the need for, and have the preparation and ability to engage in independent and life-long learning in the broadest context of technological change.

# **COURSE STRUCTURE, OBJECTIVES & OUTCOMES**

## **COURSE STRUCTURE**

Concrete Technology lab will have a continuous evaluation during 5<sup>th</sup> semester for 25 sessional marks and 50 end semester examination marks.

Out of the 25 marks for internal evaluation, day-to-day work in the laboratory shall be evaluated for 15 marks and internal practical examination shall be evaluated for 10 marks conducted by the laboratory teacher concerned.

The end semester examination shall be conducted with an external examiner and internal examiner. The external examiner shall be appointed by the principal / Chief Controller of examinations

## **COURSE OBJECTIVE**

The objective of this lab is to teach the student basic concrete fundamentals in various civil engineering applications, especially mix designs with admixtures.

## **COURSE OUTCOME**

At the end of the course, the student will be able to: Master the design of various mix proportions for concrete required for different civil engineering applications.

1. Evaluate the strength of cement
2. Analyze the characteristics of aggregates.
3. Perform the tests on fresh concrete
4. Evaluate the strength of the hardened concrete
5. Evaluate the strength of structure

## **COURSE ARTICULATION MATRIX (CO - PO / PSO MAPPING):**

<b>Program outcomes</b>	<b>1</b>	<b>2</b>	<b>3</b>	<b>4</b>	<b>5</b>	<b>6</b>	<b>7</b>	<b>8</b>	<b>9</b>	<b>10</b>	<b>11</b>	<b>12</b>	<b>PSO 1</b>	<b>PSO 2</b>	<b>PSO 3</b>
CE317.1	3	3	3	3	3	0	0	0	0	0	0	3	3	3	3
CE317.2	3	3	2	3	3	0	0	0	0	0	0	3	3	3	3
CE317.3	3	3	2	3	3	0	0	0	0	0	0	3	3	3	3
CE317.4	3	3	2	3	3	0	0	0	0	0	0	3	3	3	3
CE317.5	3	1	3	3	3	0	0	0	0	0	0	3	3	3	3
Total	15	13	12	15	15	0	0	0	0	0	0	15	15	15	15
Average	3	2.6	2.4	3	3	0	0	0	0	0	0	3	3	3	3

## LIST OF EXPERIMENTS

### **I. Test on Cement**

1. Normal Consistency and fineness of cement.
2. Initial setting time and final setting time of cement.
3. Specific gravity of cement
4. Soundness of cement.
5. Compressive strength of cement.
6. Workability test on concrete by compaction factor, slump and Vee-bee.

### **II. Test on Aggregate**

1. Sieve Analysis and gradation charts (Job mix formula using Rothfuch's charts)
2. Bulking of sand, Bulk and compact densities of fine and coarse aggregates

### **III. Test on Fresh Concrete**

1. Slump test
2. CF (compact factor stress)
3. Vee-bee Test
4. Flow Table Test

### **IV. Test on hardened concrete**

1. compression test on cubes & Cylinders
2. flexure test
3. Splitting Tensile Test
4. Modulus of Elasticity

### **V. Non-Destructive Test of Concrete**

1. Rebound Hammer
2. Ultrasound pulse velocity (UPV)

# **1. TESTS ON CEMENT**

## EXPERIMENT 1

### NORMAL CONSISTENCY OF CEMENT

#### AIM:

Normal consistency test is used to optimum percentage of water content required for a cement paste.

#### APPARATUS:

1. Vicat apparatus (conforming to IS: 5513 - 1976) with plunger (10 mm in diameter)
2. Vicat mould
3. Gauging trowel
4. Measuring jar
5. Balance
6. Tray.

#### INTRODUCTION:

The standard consistency of a cement paste is defined as that consistency which will permit the Vi-cat plunger to penetrate to a point 5 to 7 mm from the bottom of the Vicat mould. For finding out initial setting time, final setting time, soundness of cement and compressive strength of cement, it is necessary to fix the quantity of water to be mixed in cement in each case. This experiment is intended to find out the quantity of water to be mixed for a given cement to give a cement paste of normal consistency and can be done with the help of Vi-cat apparatus.

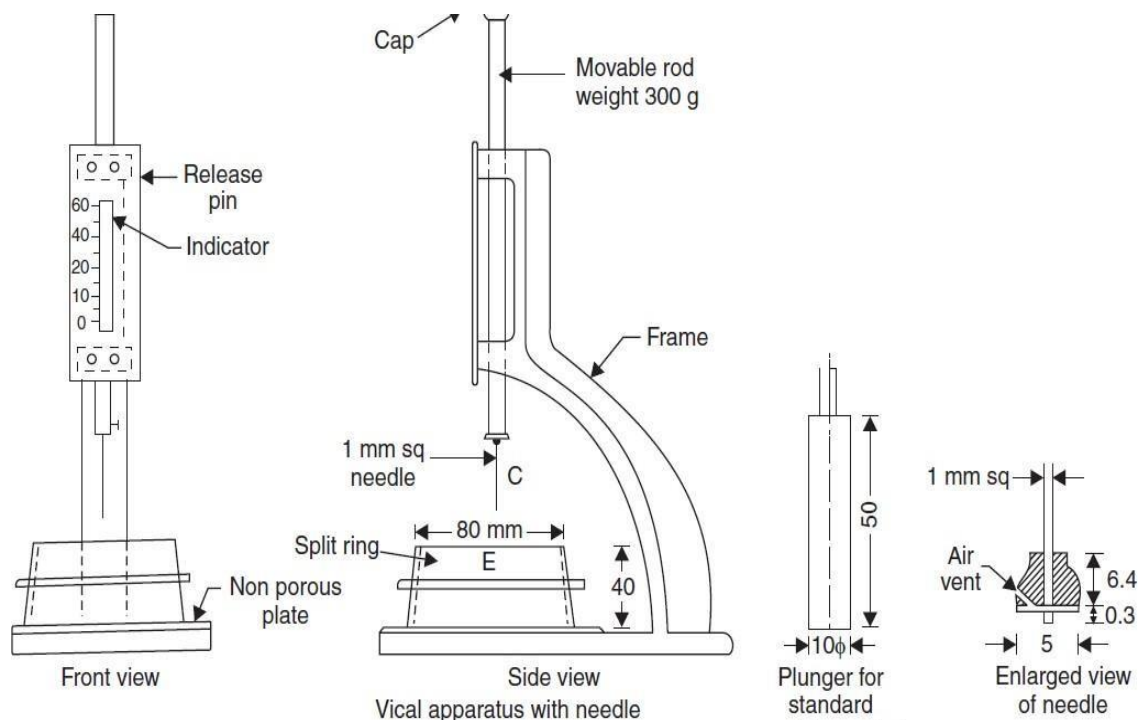

#### PROCEDURE:

1. Prepare a paste of weighed quantity of cement (300 grams) with a weighed quantity of potable or distilled water, starting with 28% water of 300g of cement.
2. The percentage of water to be taken according to the room temperature  $27 \pm 5^{\circ}\text{C}$ .

3. Take care that the time of gauging is not less than 3 minutes, not more than 5 minutes and the gauging shall be completed before setting occurs.
4. The gauging time shall be counted from the time of adding the water to the dry cement until commencing to fill the mould.
5. Fill the Vi-cat mould with this paste, the mould resting upon a non-porous plate.
6. After completely filling the mould, trim off the surface of the paste, making it in level with the top of the mould. The mould may slightly be shaken to expel the air.
7. Place the test block with the mould, together with the non-porous resting plate, under the rod bearing the plunger (10mm diameter), lower the plunger gently to touch the surface of the test block and quickly release, allowing it to penetrate into the paste.
8. This operation shall be carried out immediately after filling the mould.
9. Prepare trial pastes with varying percentages of water and test as described above until the amount of water necessary for making the standard consistency as defined above is obtained.
10. Express the amount of water as a percentage by weight of the dry cement.

**CALCULATIONS:**

1 gm per cc = 1 ml of water

$$P = \frac{W}{C} \times 100$$

Where P = percentage of water (b)

W = water required in ml (c)

C = weight of cement required (a).

**OBSERVATIONS:**

S.No	Weight of cement taken in gms (a)	Water taken in % (b)	Water taken in ml (c)	Plunger penetration (mm)	Consistency of cement in % by weight b/a * 100
1	400	28	112		
2	400	30			
3	400	32			
4	400	34			
5	400	36			

**RESULT:** Normal consistency for the given sample of cement is \_\_\_\_\_.

**FINENESS OF CEMENT**

**AIM:**

To determine the fineness of the given sample of cement by sieving.

**APPARATUS:**

1. IS-90-micron sieve conforming to IS:460-1965
2. Standard balance
3. Weights
4. Brush.



## INTRODUCTION:

The fineness of cement has an important bearing on the rate of hydration and hence on the rate of gain of strength and on the rate of evolution of heat. Finer cement offers a greater surface area for hydration and hence the faster and greater the development of strength. Increase in fineness of cement is also found to increase the drying shrinkage of concrete. Fineness of cement is tested either by sieving or by determination of specific surface by air-permeability apparatus. Specific surface is the total surface area of all the particles in one gram of cement.

## FINENESS BY SIEVING:

### PROCEDURE:

1. Weigh accurately 100 g of cement and place it on a standard 90 microns IS sieve.
2. Break down any air-set lumps in the cement sample with fingers.
3. Continuously sieve the sample giving circular and vertical motion for a period of 15 minutes.
4. Weigh the residue left on the sieve. As per IS code the percentage residue should not exceed 10%.

### OBSERVATIONS:

S. No	Weight of sample taken(g)	Weight of residue(g)	Fineness (%)

Average fineness of cement is \_\_\_\_\_.

**RESULT:** Fineness of given sample of cement is \_\_\_\_\_.

### VIVA QUESTIONS:

1. What is the percentage of water required for preparing 1:3 cement sand mortar for compressive strength test?
2. What is significance of the test?
3. What are IS specifications for compressive strength of 1:3 cement sand mortar after 3 days and 7 days?
4. What is the minimum number of specimens to be made or each age of testing?
5. How do you determine the compressive strength of cement?
6. How is the curing of a test specimen done?
7. Why should not the specimen be allowed to dry until they are tested?
8. What is the rate of loading?
9. What do you understand by standard consistency?
10. What is the weight of the moving part of the vicat apparatus?
11. What are the dimensions of the plunger?
12. What is importance of the test?

13. What precautions do you observe in performing the above tests?
14. What is the field test to test the fineness of cement?
15. What is the diameter of the plunger?
16. As per the IS code the % of cement on the sieve shouldn't exceed?
17. State the importance of this test?
18. \_\_\_\_\_% of water for 300g of cement.
19. \_\_\_\_\_microns sieve is used for the experiment.
20. What is meant by the normal consistency of the cement?
21. What precautions do you observe in performing the above tests?
22. What are the specifications for setting times of various types of cements recommended for use on a construction site?
23. What is the initial setting time of cement?
24. What is the final setting time of cement?
25. What is meant by plasticity?
26. Explain about elasticity of cement.
27. What are the initial setting time for self - compacting concrete?
28. What are the final setting time for self - compacting concrete?
29. Cement should sieve in \_\_\_\_\_no.
30. What is the field test of fineness of cement?
31. Fineness of cement\_\_\_\_\_.
32. Give the difference between normal consistency and standard consistency.
33. What is standard consistency?
34. When the cement paste is tested within the gauging time. What is the value of gauging time?
35. How many moulds required for compression strength test of cement?
36. Write the formula for normal consistency.
37. Calculate standard consistency (%) when 100 ml of water is added in 1000 g of cement.
38. What is the normal consistency for OPC?
39. For making cement paste, what is the amount of water we need?
40. The relative humidity of laboratory should be \_\_\_\_\_for standard consistency.
41. What are the ingredients of cement?
42. Write the chemical composition of cement.
43. Write short note on hydration.
44. What are the properties of Ordinary Portland cement?
45. Differentiate between flash set and false set of cement.
46. List out various tests on Cement?
47. Initial Setting Time of OPC?
48. Final Setting Time of OPC?
49. List out Grades of Cement available in Market?
50. \_\_\_\_\_is not use to make Portland Cement (PC)?

## EXPERIMENT 2

### INITIAL AND FINAL SETTING TIMES OF CEMENT

#### AIM:

To determine the initial and final setting times for the given sample of cement.

#### APPARATUS:

1. Vicat apparatus (conforming to IS: 5513-1976) with attachments
2. Balance
3. Weights
4. Gauging trowel.

#### INTRODUCTION:

In actual construction dealing with cement, mortar or concrete, certain time is required for mixing, transporting and placing. During this time cement paste, mortar, or concrete should be in plastic condition. The time interval for which the cement products remain in plastic condition is known as the setting time. Initial setting time is regarded as the time elapsed between the moment that the water is added to the cement to the time that the paste starts losing its plasticity. The final setting time is the time elapsed between the moment the water is added to the cement, and the time when the paste has completely lost its plasticity and has attained sufficient firmness to resist certain pressure. The constituents and fineness of cement is maintained in such a way that the concrete remains in plastic condition for certain minimum time. Once the concrete is placed in the final position, compacted and finished it should lose its plasticity in the earliest possible time so that it is least vulnerable to damages from external destructive agencies. This time should not be more than 10 hours which is referred to as final setting time. Initial setting time should not be less than 30 minutes.

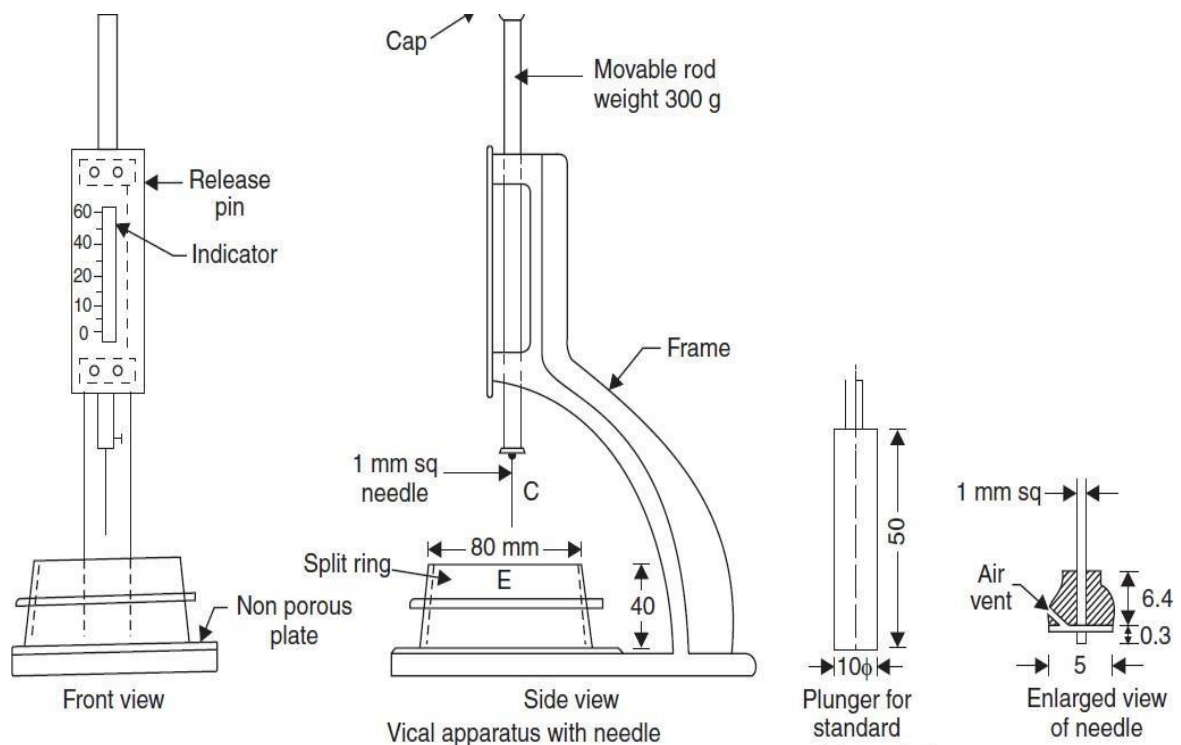

**PROCEDURE:**

Preparation of Test Block:

1. Prepare a neat cement paste by gauging 300 grams of cement with 0.85 times the water required to give a paste of standard consistency (0.85P).
2. Potable or distilled water shall be used in preparing the paste.
3. The paste shall be gauged in the manner and under the conditions prescribed in determination of consistency of standard cement paste.
4. Start a stop-watch at the instant when water is added to the cement.
5. Fill the mould with the cement paste gauged as above the mould resting on a nonporous plate.

Fill the mould completely and smooth off the surface of the paste making it level with the top of the mould. The cement block thus prepared in the mould is the test block.

**DETERMINATION OF INITIAL SETTING TIME:**

1. Place the test blocks confined in the mould and rest it on the non-porous plate, under the rod bearing initial setting needle, lower the needle gently in contact with the surface of the test block and quickly release, allowing it to penetrate into the test block.
2. In the beginning, the needle will completely pierce the test block.
3. Repeat this procedure until the needle, when brought in contact with the test block and released as described above, fails to pierce the block to a point 5 to 7 mm measured from the bottom of the mould shall be the initial setting time.

**DETERMINATION OF FINAL SETTING TIME:**

1. Replace the needle of the Vicat apparatus by the needle with an annular attachment.
2. The cement shall be considered as finally set when, upon applying the needle gently to the surface of the test block, the needle makes an impression there on, while the attachment fails to do so.
3. The period elapsed between the time when water is added to the cement and the time at which the needle makes an impression on the surface of test block while the attachment fails to do so shall be the final setting time.

**PRECAUTIONS:**

Clean appliances shall be used for gauging. All the apparatus shall be free from vibration during the test. The temperature of water and that of the test room, at the time of gauging shall be  $27^{\circ}\text{C} + 20^{\circ}\text{C}$ . Care shall be taken to keep the needle straight.

**OBSERVATIONS:**

Time in minutes	
Height in mm fails to penetrate	

**RESULT:**

Initial setting time for the given sample of cement =

Final setting time for the given sample of cement =

## VIVA QUESTIONS:

1. What do you understand by initial and final setting times of a cement sample?
2. What precautions do you observe in performing the above tests?
3. What are the specifications for setting times of various types of cements recommended for use on a construction site?
4. What is the amount of water to be added for initial setting time?
5. What is the difference between setting and hardening?
6. Differentiate between density and specific gravity of a material.
7. State the importance of this test.
8. Name other methods that can be used for finding the specific gravity of cement.
9. What is the effect on the specific gravity value if the air bubbles are not removed completely?
10. Why is a constant temperature bath used in this experiment?
11. What is the initial setting time of cement?
12. What is the final setting time of cement?
13. How much amount of water is required for cement consistency?
14. What are the initial setting times for self-compacting concrete?
15. What are the final setting times for self-compacting concrete?
16. What is the apparatus used for this experiment?
17. State the purpose of this experiment?
18. What is the temperature of the test room?
19. What precautions do you observe in performing the above tests?
20. What is the specific gravity of the cement?
21. What is the percentage of water required for preparing 1:3 cement sand mortar for compressive strength test?
22. What is the significance of the test?
23. What are the IS specifications for compressive strength of 1:3 cement sand mortar after 3 days and 7 days?
24. What is the minimum number of specimens to be made for each age of testing?
25. How do you determine the compressive strength of cement?
26. What is the difference between setting and hardening?
27. Differentiate between density and specific gravity of a material.
28. State the importance of this test.
29. Name other methods that can be used for finding the specific gravity of cement.
30. Explain about plasticity of cement.
31. In cement hardening process, \_\_\_\_\_ instants are very important.
32. Initial setting time of OPC should not be less than \_\_\_\_\_.
33. Final setting time of cement should not be more than \_\_\_\_\_.
34. In the soundness test, the whole assembly is immersed in water for \_\_\_\_\_.
35. Initial setting time of Low Heat Cement should not be less than \_\_\_\_\_.
36. If  $t_1$  = Time at which water is first added to cement,  
 $t_2$  = Time when needle fails to penetrate 5 mm to 7 mm from bottom of the mould,  
 $t_3$  = Time when the needle makes an impression, but the attachment fails to do so, then what is initial setting time?
37. If  $t_1$  = Time at which water is first added to cement,  
 $t_2$  = Time when needle fails to penetrate 5 mm to 7 mm from bottom of the mould,  
 $t_3$  = Time when the needle makes an impression, but the attachment fails to do so, then what is final setting time?
38. What is the capacity of measuring cylinder?
39. In cement hardening process, \_\_\_\_\_ instants are very important.

40. What is the admixture used to increase the setting time of concrete?
41. Define plastic stage
42. What do you mean by elastic stage?
43. How the water content is calculated to get the standard consistency?
44. Mention the dimensions of the needle used in Vicat apparatus.
45. Give the dimensions of the cylindrical mould.
46. Dimension of the plunger used for normal consistency.
47. The plate used under the cylindrical mould is non – porous plate (TRUE / FALSE).
48. Draw the diagram of release pin indicator.
49. Draw the diagram of enlarged view of needle.
50. Give any two instructions of storing cement.

### **EXPERIMENT 3**

## **SPECIFIC GRAVITY OF CEMENT**

### **AIM:**

To determine the specific gravity of given sample of hydraulic cement.

### **APPARATUS:**

1. Physical balance
2. Specific gravity bottle of 50ml capacity
3. Clean kerosene.

### **INTRODUCTION:**

Specific gravity is defined as the ratio between weight of a given volume of material and weight of an equal volume of water. To determine the specific gravity of cement, kerosene is used which does not react with cement.



### **PROCEDURE:**

1. Clean and dry the specific gravity bottle and weigh it with the stopper (W1).
2. Fill the specific gravity bottle with cement sample at least half of the bottle and weigh with stopper (W2).
3. Fill the specific gravity bottle containing the cement, with kerosene (free of water) placing the stopper and weigh it (W3).
4. While doing the above do not allow any air bubbles to remain in the specific gravity bottle.
5. After weighing the bottle, the bottle shall be cleaned and dried again.
6. Then fill it with fresh kerosene and weigh it with stopper (W4).
7. Remove the kerosene from the bottle and fill it with full of water and weigh it with stopper (W5).
8. All the above weighing should be done at the room temperature of  $27^{\circ}\text{C} + 10^{\circ}\text{C}$ .

**OBSERVATIONS:**

Description of item	Trial 1	Trial 2	Trial 3
Weight of empty bottle W1 g			
Weight of bottle + Cement W2 g			
Weight of bottle + Cement + Kerosene W3 g			
Weight of bottle + Full Kerosene W4 g			
Weight of bottle + Full Water W5 g			

Specific gravity of Kerosene  $S_k = W4 - W1 / W5 - W1$ .

Specific gravity of Cement  $S_c = W2 - W1 / ((W4 - W1) - (W3 - W2)) * S_k S_c$   
 $= (W2 - W1) * (W4 - W1) / ((W4 - W1) - (W3 - W2)) * (W5 - W1)$

**PRECAUTION:**

1. Only kerosene which is free of water shall be used.
2. At time of weighing the temperature of the apparatus will not be allowed to exceed the specified temperature.
3. All air bubbles shall be eliminated in filling the apparatus and inserting the stopper.
4. Weighing shall be done quickly after filling the apparatus and shall be accurate to 0.1 mg.
5. Precautions shall be taken to prevent expansion and overflow of the contents resulting from the heat of the hand when wiping the surface of the apparatus.

**RESULT:**

Average specific gravity of given sample of cement =

**VIVA QUESTIONS:**

1. Differentiate between density and specific gravity of a material.
2. State the importance of this test.
3. Name other methods that can be used for finding the specific gravity of cement
4. What is the effect on the specific gravity value if the air bubbles are not removed completely
5. Why constant temperature bath is used in this experiment.
6. Why do we use kerosene or naphtha in this experiment?
7. Define the slump of concrete
8. State the significance of slump test
9. How do you determine the slump of the concrete?
10. Differentiate by sketches the terms of true slump, shear and collapse type of slumps.
11. What are the precautions to be taken while conducting this experiment?
12. What is the purpose of conducting this experiment?



13. What is the specific gravity of the kerosene?
14. What is the specific gravity of the cement?
15. What is the capacity of the specific gravity bottle?
16. What should be the room temperature while conducting the experiment?
17. Why do we use kerosene to determine the specific gravity of cement?
18. Why are we calculating this value for cement?
19. What is the significance of specific gravity of cement?
20. What is the other name for the specific gravity bottle?
21. What is significance of the test?
22. What are IS specifications for compressive strength of 1:3 cement sand mortar after 3 days and 7 days?
23. What is the minimum number of specimens to be made or each age of testing?
24. What do you understand by standard consistency?
25. What is the weight of the moving part of the vicat apparatus?
26. What are the dimensions of the plunger?
27. How do you determine the slump of the concrete?
28. Differentiate by sketches the terms of true slump, shear and collapse type of slumps
29. Define the workability and consistency of freshly mixed concrete
30. The quantity of gypsum is added\_\_\_\_\_to\_\_\_\_\_%.
31. What do you mean by specific gravity?
32. Which type of apparatus used in specific gravity of cement test?
33. What is the capacity of pycnometer?
34. According to IS, how much of specific gravity of cement is preferred?
35. What do you mean by soundness?
36. Which type of apparatus used in soundness of cement test?
37. According to IS, how much of soundness of cement is preferred?
38. What is the disadvantage, if soundness is too high?
39. Which components enhance the soundness property in cement?
40. Why we have to test the soundness of test?
41. Give the formula for specific gravity of cement.
42. Density of cement is ranging between 3.1-3.16g/cc by this, cement is 3.16 times heavier than water of the same volume. (TRUE/ FALSE).
43. If the specific gravity is 3.19, then the pores in cement are filled with the moisture content. (TRUE/ FALSE).
44. If the cement is exposed to extreme moisture content due to bad weather conditions, then the specific gravity of cement may go up to 3.19. (TRUE/ FALSE).
45. The IS code for Specific gravity test is\_\_\_\_\_.
46. The specific gravity of Kerosene is\_\_\_\_\_.
47. The specific gravity of water is\_\_\_\_\_.
48. A good cement should have the Specific gravity of\_\_\_\_\_.
49. The practical will be done within\_\_\_\_\_temperature.
50. It is a value to calculate whether the material is able to sink or float on water. Every material has some specific gravity. The value is normally in digits like 0.1 – 100. If the value is less than 1, then the material will float on water. If the value is greater than 1, then the material will sink. (TRUE/ FALSE).

## EXPERIMENT 4

### SOUNDNESS OF CEMENT

#### AIM:

To determine the soundness of the given sample of cement by "Le Chatelier" Method.

#### APPARATUS:

1. Le Chatelier apparatus conforming to IS 5514-1969
2. Balance
3. Weights
4. Water bath.

#### INTRODUCTION:

It is essential that the cement concrete shall not undergo appreciable change in volume after setting. This is ensured by limiting the quantities of free lime, magnesia and sulphates in cement which are the causes of the change in volume known as unsoundness. Unsoundness in cement does not come to surface for a considerable period of time. This test is designed to accelerate the slaking process by the application of heat and discovering the defects in a short time. Unsoundness produces cracks, distortion and disintegration there by giving passage to water and atmospheric gases which may have injurious effects on concrete and reinforcement. The apparatus for conducting the test consists of small split cylinder of spring brass or other suitable metal of 0.5mm thickness forming a mould 30 mm internal diameter and 30mm high. On either side of the split mould are attached to indicators with pointed ends, the distance from these ends to the centre of the cylinder being 165 mm. The mould shall be kept in good condition with the jaws not more than 50mm apart.



**PROCEDURE:**

1. Place the lightly oiled mould on a lightly oiled glass sheet and fill it with cement paste formed by gauging cement with 0.78 times the water required to give a paste of standard consistency.
2. The paste shall be gauged in the manner and under the conditions prescribed in determination of consistency of standard cement paste, taking care to keep the edges of the mould gently together
3. While this operation is being performed cover the mould with another piece of glass sheet, place a small weight on this covering glass sheet and immediately submerge the whole assembly in water at a temperature of 27<sup>0</sup>C- 20<sup>0</sup>C and keep there for 24 hours.
4. Measure the distance separating the indicator points.
5. Submerge the moulds again in water at the temperature prescribed above.
6. Bring the water to boiling, with the mould kept submerged for 25 to 30 minutes, and keep it boiling for three hours.
7. Remove the mould from the water allow it to cool and measure the distance between the indicator points.
8. The difference between these two measurements represents the expansion of the cement.
9. For good quality cement this expansion should not be more than 10mm.

**OBSERVATIONS:**

Initial distance between the indicator points in mm =

Final distance between the indicator points in mm =

Expansion in mm =

final length - initial length =

**RESULT:**

Expansion in mm.

**VIVA:**

1. What is the purpose of conducting this experiment?
2. What are the precautions to be taken while conducting the experiment?
3. What should be the lime content in the cement?
4. What should be the temperature of water?
5. What is the thickness of the split cylinder?
6. What are the dimensions of the split cylinder?
7. For the good quality of cement the expansion should not be more than\_\_\_\_\_.
8. How many minutes the mould should be submerged in the boiling water?
9. \_\_\_\_\_times of water required for the consistency of cement.
10. What is the metal used to make the split cylinder?
11. Is there any field test for the soundness test?
12. Mention the distance between the glass plates?

13. The quantity of gypsum is added \_\_\_\_\_ to \_\_\_\_\_ %.
14. The quantity of gypsum is added depends upon the \_\_\_\_\_ content.
15. The unsoundness in cement is due to the presence of \_\_\_\_\_.
16. The magnesia content allowed in cement is limited to \_\_\_\_\_.
17. What is meant sampling?
18. Explain heat of hydration.
19. What is the composition of lime in cement?
20. Mention 5 types of cements.
21. How do you determine the slump of the concrete?
22. Differentiate by sketches the terms of true slump, shear and collapse type of slumps
23. Define the workability and consistency of freshly mixed concrete
24. Excess of \_\_\_\_\_ amount causes cement unsound.
25. What do you understand by initial and final setting times of a cement sample
26. What precautions do you observe in performing the above tests?
27. What are is specifications for setting times of various types of cements recommended for use on a construction site
28. Explain about rapid hardening cement.
29. What are the uses of low heat cement?
30. What are the properties of quick setting cement?
31. How does soundness affect the strength of cement?
32. What is the purpose of the Soundness Test in cement?
33. How can the soundness of cement be reduced?
34. What is the correct value of soundness of cement?
35. What is the use of soundness test of cement?
36. What is the soundness test of cement?
37. What is expensive cement?
38. What is composite cement?
39. What is the effect in soundness of cement due to aeration of cement specified in IS 12269?
40. Name the apparatus for soundness test of cement.
41. Apparatus used for Soundness of Cement?
42. State the reasons of unsoundness of cement.
43. Explain the role of gypsum in cement.
44. Brief the Le - Chatelier apparatus along with its limitations.
45. What should be the temperature during the practical is conducting?
46. Initial distance between the indicator points in mm \_\_\_\_\_.
47. Final distance between the indicator points in mm \_\_\_\_\_.
48. Give the limit of expansion \_\_\_\_\_.
49. Give the internal diameter of the cylinder mould.
50. What is the external diameter of the mould.

## **EXPERIMENT 5**

### **COMPRESSIVE STRENGTH OF CEMENT**

#### **AIM:**

To determine the compressive strength of standard cement mortar cubes compacted by means of standard vibration machine.

#### **APPARATUS:**

1. Vibration machine and cube moulds of size 7.06 cms (Conforming to IS: 4031- 1988).

#### **STANDARD SAND:**

The standard sand to be used in the test shall conform to IS: 650-1991 or sand passing 100 percent through 2 mm sieve and retained 100 percent on 90 microns IS sieve. 2mm to 1mm 33.33 percent 1mm to 500 microns 33.33 percent 500mm to 90 microns 33.33 percent.

#### **INTRODUCTION:**

The compressive strength of cement mortars is determined in order to verify whether the cement conforms to IS specifications and whether it will be able to develop the required compressive strength of concrete. The average compressive strength of at least three mortar cubes (area of the face 50 cm<sup>2</sup>) composed of one part of cement and three parts of standard sand should satisfy IS code specifications.



#### **PROCEDURE:**

Mix proportions and mixing:

1. Clean appliances shall be used for mixing and the temperature of the water and that of the test room at the time when the above operations are being performed shall be  $27 \pm 2^{\circ}\text{C}$ .
2. Place in a container a mixture of cement and standard sand in the proportion of 1:3 by weight mix it dry, with a trowel for one minute and then with water until the mixture is of uniform colour.
3. The quantity of water to be used shall be as specified below.
4. In any element, it should not take more than 4 minutes to obtain uniform coloured mix.

5. If it exceeds 4 minutes the mixture shall be rejected, and the operation repeated with a fresh quantity of cement, sand and water.
6. The material for each cube shall be mixed separately and the quantity of cement standard sand and water shall be as follows: Cement 200 gms Standard sand 600 gms, Water  $(P/4 + 3)$  percent of combined weight of cement and sand, where p is the percentage of water required to produce a paste of standard consistency.

#### **MOULDING SPECIMENS:**

1. In assembling the moulds ready for use, cover the joints between the halves of the mould with a thin film of petroleum jelly and apply a similar coating of petroleum jelly between the contact surfaces of the bottom of the mould and its base plate in order to ensure that no water escapes during vibration.
2. Treat the interior faces of the mould with a thin coating of mould oil.
3. Place the assembled mould on the table of the vibration machine and firmly hold it in position by means of suitable clamps.
4. Securely attach a hopper of suitable size and shape at the top of the mould to facilitate filling and this hopper shall not be removed until completion of the vibration period.
5. Immediately after mixing the mortar, place the mortar in the cube mould and rod with a rod.
6. The mortar shall be rodded 20 times in about 8 seconds to ensure elimination of entrained air and honey combing.
7. Place the remaining quantity of mortar in the hopper of the cube mould and rod again as specified for the first layer and then compact the mortar by vibrations.
8. The period of vibration shall be two minutes at the specified speed of  $12,000 + 400$  vibrations per minute.
9. At the end of vibration remove the mould together with the base plate from the machine and finish the top surface of the cube in the mould by smoothing surface with the blade of a trowel.

#### **CURING SPECIMEN:**

1. Keep the filled moulds at a temperature of  $27 \pm 20$  C in an atmosphere of at least 90 % relative humidity for about 24 hours after completion of vibration.
2. At the end of that period remove them from the moulds.
3. Immediately submerge in clean fresh water and keep them under water until testing.
4. The water in which the cubes are submerged shall be renewed every 7 days and shall be maintained at a temperature of  $27 \pm 20$  C.
5. After they have been taken out and until they are tested the cubes shall not be allowed to become dry.

#### **TESTING:**

1. Test three cubes for compressive strength at the periods mentioned under the relevant specification for different hydraulic cements, the periods being reckoned from the completion of vibration.
2. The compressive strength shall be the average of the strengths of three cubes for each period of curing.

3. The cubes shall be tested on their sides without any packing between the cube and the steel plates of the testing machine.
4. One of the platens shall be carried base and shall be self-adjusting and the load shall be steadily and uniformly applied starting from zero at a rate of 350 Kgs/Cm<sup>2</sup>/ min. The cubes are tested at the following periods Ordinary Portland cement 3, 7 and 28 days. Rapid hardening Portland cement 1 and 3 days. Low heat Portland cement 3 and 7 days.

#### **CALCULATION:**

Calculate the compressive strength from the crushing load and the average area over which the load is applied.

Express the results in N/mm<sup>2</sup> to the nearest 0.05 mm<sup>2</sup>.

Compressive strength in N/mm<sup>2</sup> = P/A

Where P is the crushing load in N and

A is the area in mm<sup>2</sup> (5000 mm<sup>2</sup>).

#### **PRECAUTIONS:**

Inside of the cube moulds should be oiled to prevent the mortar from adhering to the sides of the mould.

#### **RESULT:**

The average compressive strength of the given cement at 3 days N/mm<sup>2</sup> at 7 days N/mm<sup>2</sup> at 28 days N/mm<sup>2</sup>.

#### **VIVA QUESTIONS:**

1. What do you understand by initial and final setting times of a cement sample
2. What precautions do you observe in performing the above tests?
3. What are is specifications for setting times of various types of cements recommended for use on a construction site
4. What is the amount of water to be added for initial setting time
5. What is difference between setting and hardening
6. Differentiate between density and specific gravity of a material.
7. State the importance of this test.
8. Name other methods that can be used for finding the specific gravity of cement.
9. What is the effect onthe specific gravity value if the air bubbles are not removed completely.
10. Why constant temperature bath is used in this experiment?
11. What is the average strength of the given cement at 3 days?
12. What are the precautions to be taken while conducting the experiment?
13. What is the significance of the experiment?
14. What is the compressive strength for rapid hardening cement at 3 days?
15. What is the compressive strength for low heat Portland cement at 7 days?
16. What is the compressive strength for ordinary Portland cement at 28 days?
17. What is the compressive strength for low heat Portland cement at 3 days?
18. What is the compressive strength for ordinary Portland cement at 7 days?
19. What is the compressive strength for rapid hardening cement at 7 days?

20. What is the compressive strength for ordinary Portland cement at 3 days?
21. What is the composition of lime in cement?
22. Mention 5 types of cements.
23. How do you determine the slump of the concrete?
24. Differentiate by sketches the terms of true slump, shear and collapse type of slumps
25. Define the workability and consistency of freshly mixed concrete
26. Excess of \_\_\_\_\_ amount causes cement unsound.
27. What do you understand by initial and final setting times of a cement sample
28. What precautions do you observe in performing the above tests?
29. What are the specifications for setting times of various types of cements recommended for use on a construction site
30. What are the properties of GGBS based cement?
31. Compressive strength test for 1:3 cement and sand \_\_\_\_\_.
32. Which Bouge's compounds are highly responsible for the setting of cement?
33. No. of Cube samples required for testing Compression Strength for 100 m<sup>3</sup> of concrete?
34. What is the standard w/c value for nominal mix of concrete?
35. Equipment used to test Compression Strength of Cement?
36. What does grade 33 cement indicate?
37. Ordinary Portland cement (OPC) has been classified into how many grades?
38. Grade 43 OPC is used widely for \_\_\_\_\_.
39. After how many days is the strength of cement is tested and graded according to the result?
40. The compressive strength of OPC increases with time (TRUE / FALSE).
41. Grade 43 OPC shall be rejected if it remains in bulk storage in the factory for \_\_\_\_\_.
42. The ratio of percentage of alumina to iron oxide in OPC 43 grade is \_\_\_\_\_.
43. What is the required minimum fineness for grade 53 OPC?
44. Which of the following cannot be added in 33 grade OPC after burning stage?
45. How much maximum percentage by mass of performance improvers can be added in grade 33 OPC?
46. What are the specifications of standard sand?
47. Give the formula to calculate the water content.
48. What is dimensions of the mould?
49. Give the list of IS codes for cement.
50. What is compressive strength?



## **2.TESTS ON AGGREGATE (COARSE AND FINE)**

## **EXPERIMENT 1**

### **SIEVE ANALYSIS AND GRADATION ZONE**

#### **AIM:**

The gradation and size test are used to determine aggregate particle size distribution.

#### **APPARATUS:**

AASHTO T 27 and ASTM C 136: Sieve Analysis of Fine and Coarse Aggregates

#### **INTRODUCTION:**

In a gradation and size analysis, a sample of dry aggregate of known weight is separated through a series of sieves with progressively smaller openings. Once separated, the weight of particles retained on each sieve is measured and compared to the total sample weight. Particle size distribution is then expressed as a percent retained by weight on each sieve size. Results are usually expressed in tabular or graphical format. Graphical displays almost always use the standard 0.45 power gradation graph.

#### **PROCEDURE:**

1. Obtain an aggregate sample of adequate mass from one of the following locations: aggregate stockpiles, bins, dump trucks, conveyor belt, or the roadway.
2. Mix and reduce the sample to an amount suitable for testing. This process of reducing a sample size is often referred to as “splitting” the sample.
3. Dry the test sample to a constant mass and determine the sample’s dry mass.
4. If using the washed procedure, place the dry sample in a container and cover with water. Agitate the sample to completely separate all particles finer than the No. 200 (0.075 mm) sieve from the coarser aggregate, and to bring the fine material into suspension. Immediately decant the wash water containing the suspended solids over a nest of sieves consisting of a No. 200 (0.075 mm) sieve and an upper sieve with openings in the range of No. 8 (2.36 mm) to No. 16 (1.18 mm).
5. If using the washed procedure, repeat step 4 until the wash water is clear.
6. If using the washed procedure, return the material retained on the nested sieves to the washed sample by flushing with water. Dry the washed sample to a constant mass and allow to cool. Determine mass of the sample after washing.
7. Select applicable sieves to obtain the information required by the specifications covering the material to be tested. Sieve sizes typically used for Super pave mix design are 1½ in, 1.0

inch, ¾ inch, ½ inch, 3/8-inch, No. 4, No. 8, No. 16, No. 30, No. 50, No. 100 and No. 200 (37.5, 25.0, 19.0, 12.5, 9.5, 4.75, 2.36, 1.18, 0.600, 0.300, 0.150 and 0.075 mm) sieves. Assemble the sieves in order of decreasing size of opening from top to bottom and place the nest of sieves over a pan.

8. Pour the sample into the top sieve in the nest.
9. Sieve the material in a mechanical sieve shaker.
10. Determine the mass of the material retained on each sieve size. Record the cumulative mass retained for each sieve size (the mass retained on a specific sieve size and the mass retained on all sieves with larger openings).

### **CALCULATIONS:**

Gradation may be reported as either a percentage retained or percentage passing each sieve size.

Percentage Retained on Each Sieve

$$\text{Percent retained} = \frac{M_{\text{sieve}} \times 100}{M_{\text{total}}}$$

Percent passing = 100 – percent retained.

Where:

$M_{\text{sieve}}$  = cumulative mass retained on a sieve,  $M_{\text{total}}$  = total original sample mass

Percentage Passing Each Sieve

Percent passing = 100 – percent retained.

### **NOTE:**

Report percentages to the nearest whole number, except for the percentage passing the No. 200 (0.075 mm) sieve which is reported to the nearest 0.1 %.

### **RESULT:**

Percent retained or percent passing each sieve size by mass and material finer than the 0.075 (No. 200) sieve.

## GRADATION OF AGGREGATE:

Coarse aggregates used in concrete making contain aggregates of various sizes. This particle size distribution of the coarse aggregates is termed as “Gradation”. The sieve analysis is conducted to determine this particle size distribution. It is this matrix that is vulnerable to all ills of concrete.

## GRADATION CHARTS:

### Gradation Chart

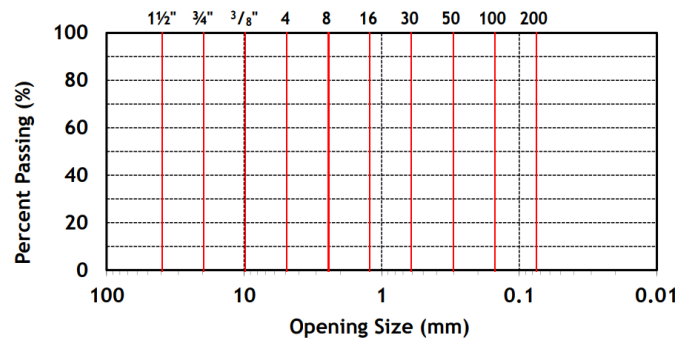

## GRADATION EXAMPLE 1:

Sample: 5/8" gravel, Initial weight: 9920g.

Sieve designation	Sieve weight empty (g)	Sieve weight full (g)	Aggregate weight retained (g)	Cumulative weight retained (g)	Cumulative percent retained (g)	Cumulative percent passing (%)
1/2 in	471	471	0			
3/8 in	428	918	490			
No. 4	423	1973	1550			
No. 8	422	2772	2350			
No. 16	417	1757	1340			
No. 30	390	2090	1700			
No. 50	365	1125	760			
No. 100	363	1113	750			
Pan	330	1390	1060			
<b>TOTAL</b>			10000 (must be within 0.3% of initial weight above)			

## GRADATION EXAMPLE 2:

Sample: 5/8" gravel, Initial weight: 9920g.

Sieve designation	Sieve weight empty (g)	Sieve weight full (g)	Aggregate weight retained (g)	Cumulative weight retained (g)	Cumulative percent retained (g)	Cumulative percent passing (%)
1/2 in				0	0.0	100.0
3/8 in				490	4.9	95.1
No. 4				2040	20.4	79.6
No. 8				4390	43.9	56.1
No. 16				5730	57.3	42.7
No. 30				7430	74.3	25.7
No. 50				8190	81.9	18.1
No. 100				8940	89.4	10.6
Pan				10000	100.0	0.0
<b>TOTAL</b>			10000 (must be within 0.3% of initial weight above)			

### VIVA:

1. In how many ways can sieve analysis can be carried out?
2. How is the percentage retained on each sieve is calculated?
3. What is a receiver in a sieve analyser?
4. The aggregate sample for the sieve analysis is placed on?
5. The sieve tests of coarse aggregate rages from?
6. Which is the limitation of performing the sieve analysis?
7. What are the types of gradation?
8. What is the other name for narrow gradation?
9. What is time of mechanical vibrator to be shaken?
10. For fine aggregates that is, sample passing through 4.75mm IS sieve, how much sample should be taken?
11. Gradation affects the properties of an aggregate. (True or false).
12. Coarse aggregate can be classified into how many groups?
13. How much percent of material which passes through a specific sieve is contained in that single-size aggregate?
14. Graded aggregate contains particles of size \_\_\_\_\_.
15. Flaky particles have \_\_\_\_\_.
16. Which size coarse aggregate is ideal for use in concrete mix?
17. Elongation index of coarse aggregates is calculated using \_\_\_\_\_.
18. In crushing test on coarse aggregates, what size particle is taken as sample?
19. What is the density of undisturbed gravel?
20. What is the symbol used for well graded gravel as per ISC system of classification?
21. What are the sizes of aggregates used in this test?

22. How many sizes of aggregates are there?
23. what is aggregate impact test?
24. What is abrasion test?
25. What are the different sizes of sieves used in this test
26. Define grades of soils.
27. How the grades of soils are classified?
28. List out the sizes of sieves used for coarse aggregate.
29. Define workability.
30. Explain about bulk density of sand.
31. According to geological origin, aggregates is/are classified into \_\_\_\_\_ types.
32. According to size, aggregates is/are classified into \_\_\_\_\_ types.
33. What is the total percentage of aggregates in concrete by volume?
34. What is the size of fine aggregates?
35. What is the size of coarse aggregates?
36. Crushed stone, gravel and ordinary sand are examples of \_\_\_\_\_

37.3 Which type of aggregate is shown here?



38.3 Which type of aggregate is shown here?



39. Aggregate crushed before the application of full load of \_\_\_\_\_
40. In crushing test, dry aggregates passing through \_\_\_\_\_ mm sieve and retained \_\_\_\_\_ mm in a cylinder.
41. According to IS: 2386 part-IV, each layer is tamped \_\_\_\_\_ times in crushing test.
42. A value less than 10 signifies an exceptionally \_\_\_\_\_ while above 35 would normally be regarded as \_\_\_\_\_
43. Los Angeles machine consists of circular drum of internal diameter \_\_\_\_\_ mm and length \_\_\_\_\_ mm.
44. Which machine is preferred for abrasion test?
45. A maximum value of \_\_\_\_\_ percent is allowed for WBM base course in Indian conditions.
46. Aggregates to be used for wearing course, the impact value shouldn't exceed \_\_\_\_\_ percent.
47. What is the range of water absorption of aggregates used in road?
48. The loss in weight should not exceed \_\_\_\_\_ percent when tested with sodium sulphate and \_\_\_\_\_ percent with magnesium sulphate solution.
49. If 60% aggregates doesn't pass through the 2.36mm sieve, then what would be the value of Aggregate impact value?
50. If the size of the coarse aggregate is, workability of concrete decreases (TRUE / FALSE).

## EXPERIMENT 2

### BULKING OF SAND

#### AIM:

To ascertain the bulking phenomena of given sample of sand.

#### APPARATUS:

1000ml measuring jar, brush.

#### INTRODUCTION:

Increase in volume of sand due to presence of moisture is known as bulking of sand. Bulking is due to the formation of thin film of water around the sand grains and the interlocking of air in between the sand grains and the film of water. When more water is added sand, particles get submerged and volume again becomes equal to dry volume of sand. To compensate the bulking effect extra sand is added in the concrete so that the ratio of coarse to fine aggregate will not change from the specified value. Maximum increase in volume may be 20 % to 40 % when moisture content is 5 % to 10 % by weight. Fine sands show greater percentage of bulking than coarse sands with equal percentage of moisture.

#### PROCEDURE:

1. Take 1000ml measuring jar.
2. Fill it with loose dry sand up to 500ml without tamping at any stage of filling.
3. Then pour that sand on a pan and mix it thoroughly with water whose volume is equal to 2% of that of dry loose sand.
4. Fill the wet loose sand in the container and find the volume of the sand which is in excess of the dry volume of the sand.
5. Repeat the procedure for moisture content of 4%, 6%, 8%, etc. and note down the readings.
6. Continue the procedure till the sand gets completely saturated i.e. till it reaches the original volume of 500ml.

#### OBSERVATIONS:

S. No	Volume of dry loose sand V1	% moisture content added	Volume of wet loose sand V2	% Bulking $\frac{V2 - V1}{V1}$
1		2%		
2		4%		
3		6%		
4		8%		
5				
6				

**GRAPH:**

Draw a graph between percentage moisture content on X-axis and percentage bulking on Y-axis. The points on the graph should be added as a smooth curve. Then from the graph, determine maximum percentage of bulking and the corresponding moisture content.

**PRECAUTIONS:**

1. While mixing water with sand grains, mixing should be thorough and uniform.
2. The sample should not be compressed while being filled in jar.
3. The sample must be slowly and gradually poured into measuring jar from its top.
4. Increase in volume of sand due to bulking should be measured accurately.

**RESULT:**

The maximum bulking of the given sand is \_\_\_\_\_ at \_\_\_\_\_ % of moisture content.

**COMMENTS:****VIVA QUESTIONS:**

1. State the importance of the compressive strength test
2. What is the minimum number of test to be conducted for each batch
3. State the sequence of mixing the ingredients of concrete
4. Why moulds are oiled before use 5. State the methods of compacting the concrete in the cube and cylinder moulds
5. How do you determine the compressive strength of the concrete?
6. Why capping is necessary for cylindrical specimens
7. State the rate of applying of load on compression specimens
8. State the nature of compression failures observed by you during testing
9. The cubes should be tested on sides and not along the direction of casting comment on this statement
10. State the relationship between cube strength and cylinder strength
11. State the importance of the test
12. State the relative bulking tendencies of fine aggregate
13. Explain void content as it implies to fine aggregate
14. How do you determine the bulking of the aggregate?
15. How would you test sand for silt and organic matter?
16. How bulking of fine aggregate is taken into account while designing a concrete mix
17. What is the reason for bulking of sand?
18. Gradation affects the properties of an aggregate. (True or false).
19. How is the percentage retained on each sieve is calculated?
20. What is a receiver in a sieve analyser?
21. What is a receiver in a sieve analyser?
22. The aggregate sample for the sieve analysis is placed on?
23. The sieve tests of coarse aggregate rages from?
24. Which is the limitation of performing the sieve analysis?
25. What are the types of gradation?



26. What is the other name for narrow gradation?
27. In which void ratio depends?
28. What is the specific gravity of coarse aggregate?
29. What is the bulk density of coarse aggregate (10mm and 20mm)?
30. What is the specific gravity of fine aggregate?
31. What do you mean by bulking?
32. "Fine aggregate do not show any bulking when it is absolutely dry". Is this statement true or false?
33. What is the percentage of bulk if fine aggregates manufactured by extremely fine sand?
34. Bulking \_\_\_\_\_ with increase in moisture.
35. Fine sand bulks \_\_\_\_\_ than coarse sand.
36. If  $h$  = height of sand when moist and  $h_1$  is the height when saturated then what is the percentage of bulking?
37. Which apparatus we don't need to calculate the bulking of fine aggregates?
38. What is bulking of coarse aggregates?
39. If the moisture content of 5 to 10% by weight, then the bulking of sand is increased by \_\_\_\_\_
40. When sand is fully dry then it's volume is \_\_\_\_\_
41. What is soundness?
42. Which apparatus we need to find soundness?
43. Why do we need to find soundness?
44. What is the maximum size of split?
45. Le Chatelier apparatus consist of \_\_\_\_\_
46. When the cement paste is filled in mould and kept in water. Then what should be the temperature of water?
47. Expansion should not be more than \_\_\_\_\_
48. If the  $Y$  is the reading of sand surface (ml) then what is the percentage of bulking?
49. What is the size of caliper?
50. What is the standard value of expansion for super sulphated cement?

## **EXPERIMENT 3**

### **BULK AND COMPACT DENSITIES OF FINE & COARSE AGGREGATE**

#### **AIM:**

To determine the specific gravity, void ratio, porosity and bulk density of given coarse and fine aggregates.

#### **APPARATUS:**

10 Kg capacity balance with weights, cylindrical containers of 1 litre and 5 litre capacities, measuring jar of 1000ml capacity.

#### **INTRODUCTION:**

The specific gravity of an aggregate is generally required for calculations in connection with cement concrete design work for determination of moisture content and for the calculations of volume yield of concrete. The specific gravity also gives information on the quality and properties of aggregate. The specific gravity of an aggregate is considered to be a measure of strength of quality of the material. Stones having low specific gravity are generally weaker than those with higher specific gravity values. The bulk density of an aggregate is used for judging its quality by comparison with normal density for that type of aggregate. It is required for converting proportions by weight into proportions by volume and is used in calculating the percentage of voids in the aggregate.

1. Specific gravity is the weight of aggregate relative to the weight of equal volume of water.
2. Void ratio is the ratio of volume of voids to the volume of solids in an aggregate.
3. Percentage of voids or porosity is the ratio of volume of voids to the total volume of a sample of an aggregate.
4. Bulk density or unit weight is the weight of material per unit volume.

#### **PROCEDURE:**

##### **COARSE AGGREGATE**

1. Find the weight of the empty container W1.
2. Take coarse aggregate in the container up to approximately half of the container and find out the weight W2.
3. Fill the container with water up to the level of the coarse aggregates so that all void space inside the aggregate is filled with water. Find its weight W3.
4. Fill the container with water after emptying it from mix of coarse aggregate and water.
5. Water should be up to the mark, up to which coarse aggregate is filled. Find its weight W4
6. Repeat the same process for another trail by taking the aggregate up to the full of the container and by filling the water up to same point.

## **OBSERVATIONS:**

Sl. No Trail 1 Trail 2

1. Weight of empty container W1.
2. Weight of container with material W2.
3. Weight of container + material + water W3.
4. Weight of container + water W4.

- i) Void ratio = Vol. of Voids / Vol of Solids  $W3 - W1 / ((W4 - W1) - (W3 - W2))$   
ii) Porosity = Vol. of Voids / Total Vol. of aggregate \*100  $W3 - W2 / (W4 - W1) * 100$   
iii) Specific gravity =  $W2 - W1 / ((W4 - W1) - (W3 - W2))$   
iv) Bulk density =  $W2 - W1 / (W4 - W1)$

## **FINE AGGREGATE:**

### **VOID RATIO AND POROSITY:**

1. Take 150 ml of dry sand (v1 ml) in clean measuring jar of 1000 ml capacity.
2. Add a measured quantity of 100 ml clean water to the above sample (v2 ml) i.e. v2=100 ml
3. Shake the jar thoroughly till all air bubbles are expelled.
4. Now note the readings against the top surface of water in the jar (V3 ml)

$$\text{Void ratio} = \frac{v1 + v2 - v3}{v3 - v2}$$

$$\text{Porosity} = \frac{v1 + v2 - v3}{v1}$$

### **SPECIFIC GRAVITY OF FINE AGGREGATES:**

1. Weigh the empty measuring jar of 1000 ml capacity = W1
2. Take the weight of empty measuring jar with 150 ml of sand Empty jar + sand =W2
3. Take the weight of empty measuring jar with 150 ml of sand and 100 ml of water Empty jar + sand + water = W3
4. Remove the mix of sand and water from bottle and fill it with water up to volume V3 then weigh it. Empty jar + water = W4
5. Specific gravity = Weight of solids / Volume of Solids  $W2 - W1 / ((W4 - W1) - (W3 - W2))$

## **RESULT:**

1. Specific gravity of course aggregate.
2. Void ratio of course aggregate.
3. Porosity of coarse aggregate.
4. Bulk density of course aggregate.
5. Specific gravity of fine aggregate.
6. Void ratio of the given fine aggregate.
7. Porosity of the given time aggregate.

## VIVA:

1. What is porosity?
2. What is permeability?
3. What is bulk density?
4. What is the difference between the density and bulk density?
5. What is specific gravity?
6. What is void ratio?
7. In which void ratio depends?
8. What is the specific gravity of coarse aggregate?
9. What is the bulk density of coarse aggregate (10mm and 20mm)?
10. What is the specific gravity of fine aggregate?
11. What is the bulk density of fine aggregate?
12. How the void ratio will be calculated?
13. In the ratio 1:4:8, which number indicates quantity of fine aggregates?
14. PGBS stands for \_\_\_\_\_.
15. Flaky particles have \_\_\_\_\_.
16. Which size coarse aggregate is ideal for use in concrete mix?
17. Compaction factor for heavily reinforced section with vibration is \_\_\_\_\_.
18. A slump of 50-100mm can be used for \_\_\_\_\_.
19. The accumulation of water on outer surface of concrete is \_\_\_\_\_.
20. State the importance of conducting the experiment?
21. The 28 days cube strength of mass concrete using aggregates of maximum size 5 cm for gravity dams should be \_\_\_\_\_.
22. Bulk density of normal weight aggregate is  $1600 \text{ kg/m}^3$  (TRUE / FALSE)
23. The unit weight of heavy weight concrete varies from \_\_\_\_\_  $\text{kg/m}^3$ .
24. The use of crushed aggregates may results in 10 to 20% higher compressive strength. Is this statement (TRUE / FALSE)?
25. S.I. unit of bulk density
26. What is void ratio?
27. The average specific gravity of natural aggregate is:
28.  $\text{Sp. Gr.} = (a-b)/c$  (TRUE / FALSE)
29. The ratio of the mass of the aggregate dried in an oven at \_\_\_\_\_ for 24 hours to the mass of the water occupying a volume equal to that of solid.
30. Aggregate abrasion value is determined by \_\_\_\_\_.
31. How many principal thermal properties are there for aggregates?
32. Coefficient of thermal expansion of concrete is \_\_\_\_\_ coefficient of thermal expansion in aggregates.
33. If the coefficient of thermal expansion of coarse aggregates and cement paste differs too much, then what happen?
34. If the coefficient of the two materials differ by more than  $5.4 \times 10^{-6}$  per  $^{\circ}\text{C}$ , then
35. For majority of aggregates, the coefficient of thermal expansion lies between approximately
36. For hydrated Portland cement, the coefficient of thermal expansion lies between approximately
37. The linear thermal coefficient of expansion lies between approximately.
38. The specific heat of the aggregates is \_\_\_\_\_.

39. The thermal conductivity of the aggregates is \_\_\_\_\_
40. "The coefficient of thermal expansion affects the heat resistance". Is this (TRUE / FALSE)?
41. A maximum value of \_\_\_\_\_ percent is allowed for WBM base course in Indian conditions.
42. Aggregates to be used for wearing course, the impact value shouldn't exceed \_\_\_\_\_ percent.
43. What is the range of water absorption of aggregates used in road?
44. The loss in weight should not exceed \_\_\_\_\_ percent when tested with sodium sulphate and \_\_\_\_\_ percent with magnesium sulphate solution.
45. If 60% aggregates doesn't pass through the 2.36mm sieve, then what would be the value of Aggregate impact value?

### **3. TESTS ON FRESH CONCRETE**

## EXPERIMENT 1

### SLUMP TEST

#### AIM:

Concrete slump test is to determine the workability or consistency of concrete mix prepared at the laboratory or the construction site during the progress of the work.

#### APPARATUS:

Mould for slump test, non-porous base plate, measuring scale, temping rod.

#### INTRODUCTION:

Concrete slump test is carried out from batch to batch to check the uniform quality of concrete during construction. The slump test is the simplest workability test for concrete, involves low cost and provides immediate results. Generally concrete slump value is used to find the workability, which indicates water-cement ratio, but there are various factors including properties of materials, mixing methods, dosage, admixtures etc. also affect the concrete slump value.

1. Very low workability: slump value 0-25mm or 0-1 inch
2. Low workability: slump value 25-50mm or 1-2 inch
3. Medium workability: slump value 50-100mm or 2-4 inch
4. High workability: slump value 100-175mm or 4-7 inch

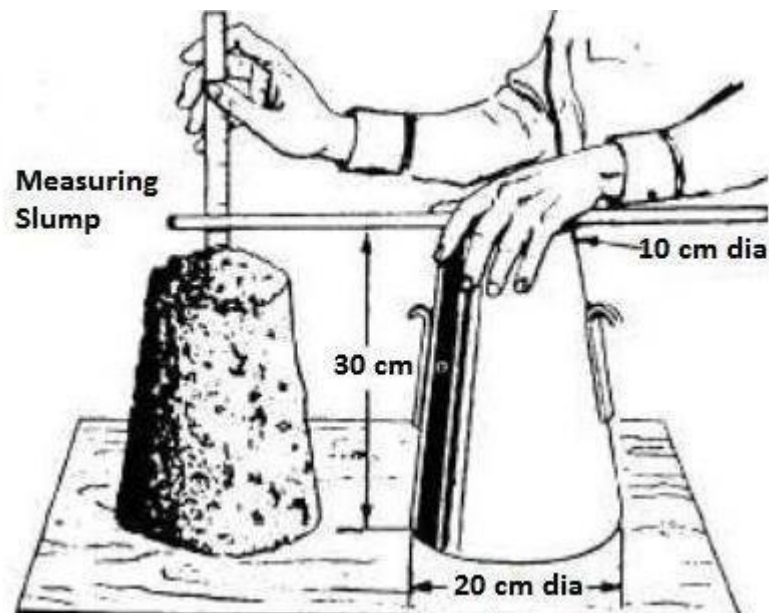

- **True Slump** – True slump is the only slump that can be measured in the test. The measurement is taken between the top of the cone and the top of the concrete after the cone has been removed as shown in figure.

- **Zero Slump** – Zero slump is the indication of very low water-cement ratio, which results in dry mixes. These type of concrete is generally used for road construction.
- **Collapsed Slump** – This is an indication that the water-cement ratio is too high, i.e. concrete mix is too wet or it is a high workability mix, for which a slump test is not appropriate.
- **Shear Slump** – The shear slump indicates that the result is incomplete, and concrete to be retested.

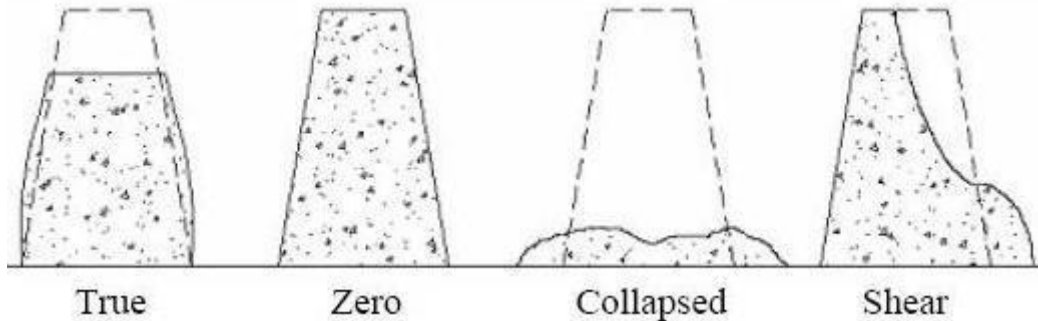

**PROCEDURE:**

1. Clean the internal surface of the mould and apply oil.
2. Place the mould on a smooth horizontal non- porous base plate.
3. Fill the mould with the prepared concrete mix in 4 approximately equal layers.
4. Tamp each layer with 25 strokes of the rounded end of the tamping rod in a uniform manner over the cross section of the mould. For the subsequent layers, the tamping should penetrate into the underlying layer.
5. Remove the excess concrete and level the surface with a trowel.
6. Clean away the mortar or water leaked out between the mould and the base plate.
7. Raise the mould from the concrete immediately and slowly in vertical direction.
8. Measure the slump as the difference between the height of the mould and that of height point of the specimen being tested.

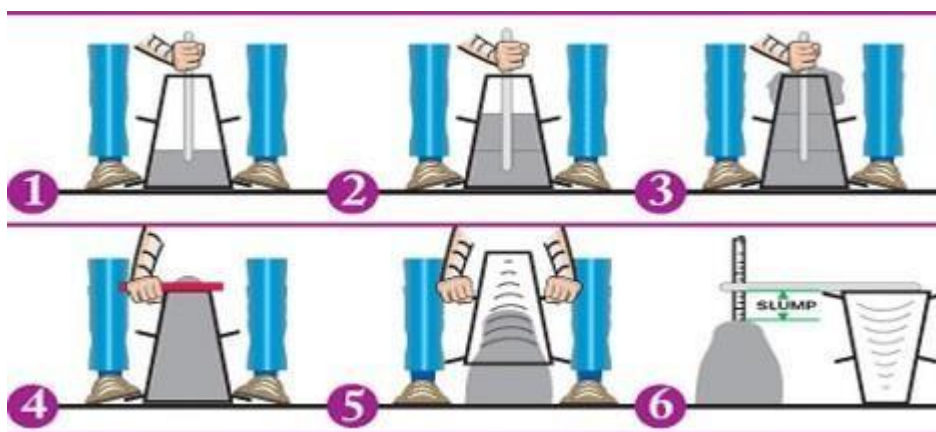

**RESULT:**

Slump for the given sample = \_\_\_\_\_mm.



**VIVA:**

1. A slump of 50-100mm can be used for\_\_\_\_\_.
2. Concrete is filled in how many layers in slump cone in slump test\_\_\_\_\_.
3. How many hoppers are there in compaction factor test?
4. What is the standard w/c value for nominal mix of concrete?
5. Slump value required for RCC Slab?
6. What is true slump?
7. Size of Concrete Cubes?
8. What are the dimensions of the slump cone?
9. List out workability tests?
10. How many strokes for each layer?
11. What is the slump value for low workability?
12. Slump value 100 – 175mm indicates\_\_\_\_\_workability.
13. What is zero slump?
14. What is collapsed slump?
15. What is shear slump?
16. What is segregation of concrete?
17. Workability means?
18. What is the density of concrete?
19. What is the slump value for medium workability?
20. What is the slump value in inch for higher workability?
21. What do you mean by workability?
22. Workability of concrete can be improved by addition
23. List out Workability Tests?
24. Slump value required for RCC Slab?
25. What is Segregation of concrete?
26. What is the standard w/c value for nominal mix of concrete?
27. How many types of tests are there to find workability?
28. These test find workability
29. Workability of concrete is measured by
30. Which test gives good results for rich mixes?
31. Which test used for low workable concretes?
32. Which test Used for high workable concretes?
33. Which test used for fiber reinforced concrete?
34. \_\_\_\_\_is practical in field test.
35. What is the compaction factor for medium degree of workability?
36. What is the Vee-Bee time for medium degree of workability?
37. The water–cement ratio is the ratio of \_\_\_\_
38. A lower ratio leads to \_\_\_\_
39. Workability can be resolved \_\_\_\_\_
40. How to improve the workability of concrete.
41. What is workability?
42. What is the compaction factor for low degree of workability?
43. What is the compaction factor for medium degree of workability?
44. What is the Vee-Bee time for medium degree of workability?
45. Clay minerals are found in most \_\_\_\_\_

46. Theoretical value for bulk modulus of clay \_\_\_\_\_
47. Young's modulus for dickite is \_\_\_\_\_
48. The grain density of the clay powders was measured using \_\_\_\_\_
49. To avoid trapped air produced by clay flocculation, we used \_\_\_\_\_ in distilled water.
50. For the cold-pressed aggregate samples, porosity, bulk and grain densities were measured with \_\_\_\_\_

## **EXPERIMENT 2**

### **CF (COMPACT FACTOR STRESS) TEST**

#### **AIM:**

Compaction factor test is the workability test for concrete conducted in laboratory.

#### **APPARATUS:**

Compaction factor apparatus consists of trowels, hand scoop (15.2 cm long), a rod of steel or other suitable material (1.6 cm diameter, 61 cm long rounded at one end) and a balance.

#### **INTRODUCTION:**

The compaction factor test is used for concrete which have low workability for which slump test is not suitable. The test is sufficiently sensitive to enable difference in workability arising from the initial process in the hydration of cement to be measured. Each test, therefore should be carried out at a constant time interval after the mixing is completed, if strictly comparable results are to be obtained. Convenient time for releasing the concrete from the upper hopper has been found to be two minutes after the completion of mixing.

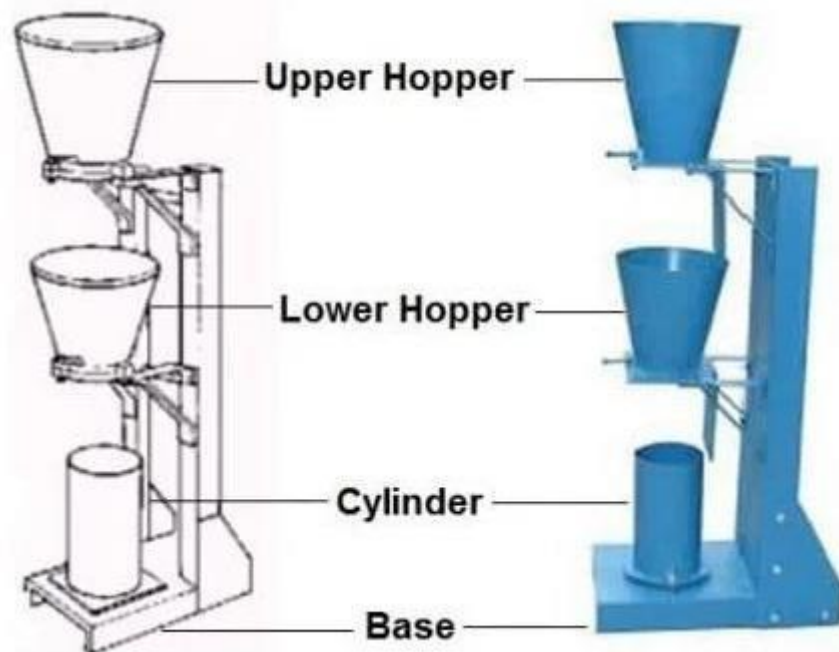

#### **PROCEDURE:**

1. Place the concrete sample gently in the upper hopper to its brim using the hand scoop and level it.
2. Cover the cylinder. Open the trapdoor at the bottom of the upper hopper so that concrete fall into the lower hopper. Push the concrete sticking on its sides gently with the rod.

3. Open the trapdoor of the lower hopper and allow the concrete to fall into the cylinder below.
4. Cut off the excess of concrete above the top level of cylinder using trowels and level it.
5. Clean the outside of the cylinder.
6. Weight the cylinder with concrete to the nearest 10 g. This weight is known as the weight of partially compacted concrete (**W1**).
7. Empty the cylinder and then refill it with the same concrete mix in layers approximately 5 cm deep, each layer being heavily rammed to obtain full compaction.
8. Level the top surface.
9. Weigh the cylinder with fully compacted. This weight is known as the weight of fully compacted concrete (**W2**).
10. Find the weight of empty cylinder (**W**).

### **CALCULATION:**

The compaction factor is defined as the ratio of the weight of partially compacted concrete to the weight of fully compacted concrete. It shall normally to be stated to the nearest second decimal place.

$$\text{Compaction Factor Value} = (W1 - W) / (W2 - W)$$

### **RESULT:**

Compaction factor of the concrete =

The Compaction factor values ranges from 0.7 to 0.95.

### **VIVA:**

1. Compaction factor for heavily reinforced section with vibration is \_\_\_\_\_.
2. Modulus of elasticity, E is calculated using \_\_\_\_\_.
3. Concrete is filled in how many layers in slump cone in slump test \_\_\_\_\_.
4. How the compaction factor value is calculated?
5. Higher compaction implies higher \_\_\_\_\_.
6. Which test is used for the high workable concretes?
7. What is the compaction factor for medium degree of workability?
8. Which test used for low workable concretes?
9. Which test gives good results for rich mixes?
10. Workability of concrete is measured by
11. How many types of tests are there to find workability?
12. What are the dimensions of upper and lower hopper?
13. What is the length and diameter of the cylinder?
14. If compaction factor of concrete is .90, then workability is \_\_\_\_\_.
15. A compaction factor of .85 for a cement concrete sample indicates \_\_\_\_\_.
16. What is meant by workability?

17. Workability of concrete can be improved by\_\_\_\_\_.
18. Workability of concrete is directly proportional to\_\_\_\_\_.
19. Workability of concrete is inversely proportional to\_\_\_\_\_.
20. The water–cement ratio is the ratio of\_\_\_\_\_.
21. IS 456 of 2000 gives the modulus of elasticity as \_\_\_\_\_
22. What is elastic strains?
23. Static modulus of elasticity of concrete has been related to its \_\_\_\_\_
24. If the value of  $f_{ck}$  is 100 then what will be the modulus of elasticity?
25. Water cement ratio is \_\_\_\_\_
26. A lower ratio leads to \_\_\_\_\_
27. For concrete exposed to a very aggressive environment the w/c should be lower than \_\_\_\_\_
28. What is the range of water in M10?
29. What is the range of water in M15?
30. What is the range of water in M20?
31. What is the range of water in M25?
32. What is the approx. quantity of water in M5?
33. What is the approx. quantity of water in M7?
34. What is the approx. quantity of water in M10?
35. What is the gel/space ratio?
36. Who has established the relation between the strength and gel/space ratio?
37. Power showed that the strength of concrete bears a specific relationship with the gel/space ratio. He found the relationship to be \_\_\_\_\_
38. What does 240 in power's experiment stands for?
39. What does  $x^3$  in power's experiment stands for?
40. What unit is present with the 240?
41. Gel/Space ratio =  $x = \text{Volume of gel} / \text{Space available} = 0.657 C / 0.319 C + W_o$ . Here C stands for?
42. Gel/Space ratio =  $x = \text{Volume of gel} / \text{Space available} = 0.657 C / 0.319 C + W_o$ . Here  $W_o$  stands for?
43. According to fig. what is the approx. value of strength of 50mm cube in MPa for gel-space ratio .6?
44. Referring to the graph below, what is the approx. value of strength of 50mm cube in MPa for gel-space ratio .8?

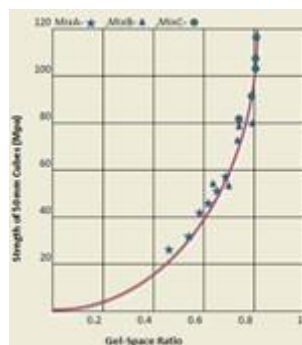

45. How many types of tests are there to find workability?
46. Workability of concrete is measured by \_\_\_\_\_
47. Which test gives good results for rich mixes?

48. Which test used for low workable concretes?
49. Which test Used for high workable concretes?
50. Which test used for fiber reinforced concrete?

## EXPERIMENT 3

### VEE - BEE TEST

#### AIM:

To determine the workability of freshly mixed concrete by using of Vee – Bee consistometer apparatus.

#### APPARATUS:

Cylindrical container, Vee-Bee apparatus (consisting of vibrating table, slump cone), Standard tamping rod, stop watch and trowels.

#### INTRODUCTION:

Vee-bee test carries out the relative effort measurement to change the mass of the concrete from a definite shape to the other. That is, as per the test, from the conical shape to the cylindrical shape by undergoing vibration process. The measurement of the effort is done by time measurement in seconds. The amount of work measured in seconds is called as the remoulding effort. The time required for the complete remoulding is a measure of the workability and is expressed in the Vee-Bee seconds. The experiment is named after the developer V Bahrmer of Sweden. The method can be also applied for dry concrete. For concrete that have slump value more than 50mm, the remoulding activity will be so fast that the measurement of time is not possible.

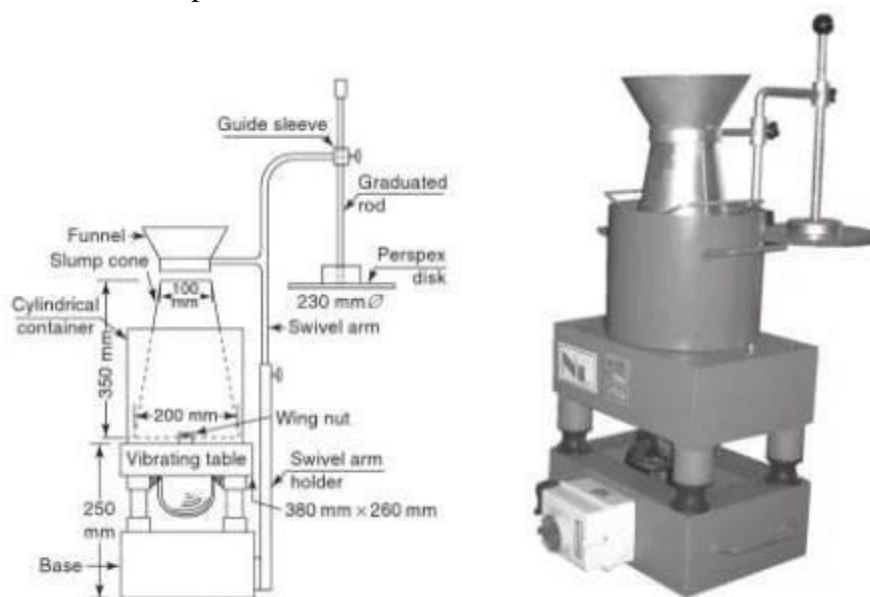

#### PROCEDURE:

1. Initially the sheet metal slump cone is placed inside the cylinder container that is placed in the consistometer. The cone is filled with four layers of concrete. Each concrete layer is one fourth the height of the cone. Each layer after pouring is subjected to twenty-five tamping with the standard tamping rod. The tamping is done with the rounded end of the rod. The strokes are

distributed in uniform manner. This must be done in such a way that the strokes conducted for the second and the subsequent layers of concrete must penetrate the bottom layers. Once the final layer has been placed and compacted, the concrete is struck off to make it in level with the help of a trowel. This makes the cone to be exactly filled.

2. After the preparation of the concrete cone, the glass disc attached to the swivel arm is moved and is placed on the top of the slump cone placed inside the cylindrical container. The glass disc has to be placed such that it touches the top of the concrete level and the reading is measured from the graduated rod.
3. Now the cylindrical cone is removed immediately by raising the cone slowly in the vertical direction. The transparent disc on the top of the concrete is placed down to the new position and the reading is determined.
4. The difference in the values measured from step 3 and step 4 will give the slump.
5. Now the electrical vibrator is switched on and at the same time we have to start the stop watch. The concrete is allowed to spread out in the cylindrical container. Until the concrete is remoulded the vibration is continued. This stage is when the surface of the concrete becomes horizontal and the concrete surface completely adheres uniformly to the transparent disc.
6. The time required for complete remoulding in seconds is recorded. This time in seconds gives us the measure of workability of the fresh concrete. This time is expressed in Vee-Bee seconds.

#### **OBSERVATION AND CALCULATIONS:**

1. Initial reading from the graduated rod, before unmoulding (a) in mm
2. The final reading on the graduated rod after removing the mould (b) in mm
3. Slump =  $a - b$  in mm
4. The time required for complete remoulding in seconds

#### **RESULT:**

Hence the consistency of the concrete is measured in \_\_\_\_\_ vee-bee seconds.



**STANDARD VALUES:**

<b>WORKABILITY DESCRIPTION</b>	<b>VEE – BEE TIME (IN SECONDS)</b>
Extremely dry	<b>32 – 18</b>
Very stiff	<b>18 – 10</b>
Stiff	<b>10 – 5</b>
Stiff plastic	<b>5 – 3</b>
Plastic	<b>3 – 0</b>
Flowing	—

**VIVA:**

1. What is Vee – Bee test?
2. State the importance of the test conducting?
3. What are the dimensions of the slump cone?
4. Who is the developer of this experiment?
5. What is the vee – bee time for extremely dry workability?
6. What is the standard value of vee – bee time for stiff plastic workability?
7. Workability Means?
8. What is Segregation of concrete?
9. What is Concrete Maturity?
10. How is aggregate impact value expressed?
11. Mix proportions of M30 grade concrete?
12. What is meant by flakiness index?
13. What are the limitations of this test?
14. Size of cube used for testing of Compression Strength of Cement?
15. Plasticizers are used for?
16. List out some of Admixtures available in market?
17. Explain about the influence of W/C ratio?
18. Nominal Mix vs Design Mix?
19. Density of Concrete?
20. What is bleeding of concrete?
21. What do you mean by workability?
22. Workability of concrete can be improved by addition\_\_\_\_\_.
23. Workability of concrete can be improved by\_\_\_\_\_.
24. Workability of concrete can be improved by\_\_\_\_\_.

- 25.2 Workability of concrete is directly proportional to \_\_\_\_\_.
- 26.2 Workability of concrete is inversely proportional to \_\_\_\_\_.
27. If compaction factor of concrete is .90, then workability is \_\_\_\_\_.
28. A compaction factor of .85 for a cement concrete sample indicates \_\_\_\_\_.
29. Adding water increases \_\_\_\_\_.
30. Why Shape and texture of aggregates is must?
31. What are the factors effect the workability of concrete?
32. How many types of tests are there to find workability?
33. Workability of concrete is measured by \_\_\_\_\_.
34. Which test gives good results for rich mixes?
35. Which test used for low workable concretes?
36. Which test Used for high workable concretes?
37. \_\_\_\_\_ is practical in field test.
38. What is the compaction factor for medium degree of workability?
39. What is the Vee-Bee time for medium degree of workability?
40. Workability can be resolved \_\_\_\_\_.
41. Which test gives good results for rich mixes?
42. Which test used for low workable concretes?
43. Which test Used for high workable concretes?
44. Which test used for fiber reinforced concrete?
45. \_\_\_\_\_ is practical in field test.
46. What is the compaction factor for medium degree of workability?
47. What is the Vee-Bee time for medium degree of workability?
48. The water–cement ratio is the ratio of \_\_\_\_\_.
49. A lower ratio leads to \_\_\_\_\_.
50. How to improve the workability of concrete?

## **EXPERIMENT 4**

### **FLOW TABLE TEST**

#### **AIM:**

To determine the workability of freshly mixed concrete by using of Vee – Bee consistometer apparatus.

#### **APPARATUS:**

Cylindrical container, Vee-Bee apparatus (consisting of vibrating table, slump cone), Standard tamping rod, stop watch and trowels.

#### **INTRODUCTION:**

As well as getting an accurate measurement of the workability of the concrete, the flow test gives an indication of the cohesion. A mix that is prone to segregation will produce a non-circular pool of concrete. Cement paste may be seen separating from the aggregate. If the mix is prone to bleeding, a ring of clear water may form after a few minutes.

#### **PROCEDURE:**

1. Before commencing test, the table top and inside of the mould is to be wetted and cleaned of all gritty material and the excess water is to be removed with a rubber squeezer.
2. The mould is to be firmly held on the centre of the table and filled with concrete in two layers, each approximately one-half the volume of the mould and rodded with 25 strokes with a tamping rod, in a uniform manner over the cross section of the mould.
3. After the top layer has been rodded, the surface of the concrete is to be struck off with a trowel so that the mould is exactly filled.
4. The mould is then removed from the concrete by a steady upward pull.
5. The table is then raised and dropped from a height of 12.5 mm, 15 times in about 15 seconds.
6. The diameter of the spread concrete is the average of six symmetrically distributed calliper measurements read to the nearest 5 mm.



## CALCULATION:

The flow of the concrete is the percentage increase in diameter of spread concrete over the base diameter of the moulded concrete, calculated from the following formula.

$$\text{Flow(\%)} = \frac{\text{Spread dia. (cm)} - 25}{25} \times 100$$

## RESULT:

The flow measured is \_\_\_\_\_percentage.

## VIVA:

1. What are the factors influencing the choice of mix proportions?
2. State the importance of the experiment?
3. What is the role of water in fresh concrete?
4. Describe the field method for assessing the workability.
5. Explain the significance of w/c ratio.
6. Discuss the factors affecting workability of concrete.
7. Explain any two tests for determining the workability of concrete?
8. How to calculate the percentage of flow?
9. What are the precautions to be taken while conducting the experiment?
10. What is flow table?
11. What is segregation of concrete?
12. What is bleeding of concrete?
13. What is the height of raising and dropping of the table?
14. What are the dimensions of the table?
15. How many strokes to be given with the tampering rod in the mould?
16. Name the apparatus for this experiment?
17. Flow table test determines the \_\_\_\_\_ of concrete.
18. The water–cement ratio is the ratio of \_\_\_\_\_.
19. A lower ratio leads to \_\_\_\_\_.
20. A lower ratio leads to \_\_\_\_\_.
21. \_\_\_\_\_ is practical in field test.
22. What is the compaction factor for medium degree of workability?
23. What is the Vee-Bee time for medium degree of workability?
24. What is concrete maturity?
25. Maturity methods provide a \_\_\_\_\_ simple approach for strength of concrete.
26. The maturity method is a \_\_\_\_\_ approach to predict the early age strength gain of concrete.
27. Maturity concept is a \_\_\_\_\_ method.
28. It \_\_\_\_\_ the quantity and \_\_\_\_\_ cost of sampling and testing
29. What does  $x^3$  in power's experiment stands for?
30. A lower ratio leads to \_\_\_\_\_
31. The material used for UHPC provides compressive strengths up to \_\_\_\_\_
32. "Where the matrix is extremely dense, a weak aggregate may become the weak". Is this statement (TRUE / FALSE)?
33. What is the compaction factor for medium degree of workability?
34. It is \_\_\_\_\_ strength and \_\_\_\_\_ permeability.

35. "High Performance concrete works out to be economical". Is it true or false?
36. "HPC is not used in high span bridges". Is it true or false?
37. Concrete having 28- days' compressive strength in the range of 60 to 100 MPa.
38. Concrete having 28-days compressive strength in the range of 100 to 150 MPa.
39. High-Performance Concrete is \_\_\_\_\_ as compared to Normal Strength Concrete.
40. The choice of cement for high-strength concrete should not be based only on mortar-cube tests but it should also include tests of compressive strengths of concrete at \_\_\_\_\_ days.
41. For high-strength concrete, a cement should produce a minimum 7-days mortar-cube strength of approximately \_\_\_\_\_ MPa.
42. \_\_\_\_\_ mm nominal maximum size aggregates gives optimum strength.
43. Due to low w/c ratio \_\_\_\_\_.
44. What could be the possible answer among the following for compressive strength of high strength concrete?
45. What could be the possible answer among the following for water cement ratio for high strength concrete?
46. Due to low w/c ratio \_\_\_\_\_.
47. Which type of aggregates are used to produce 70MPa compressive strength?
48. Maximum size of aggregates are used to produce 70MPa compressive strength is \_\_\_\_\_.
49. Maximum size of aggregates are used to produce 100MPa compressive strength is \_\_\_\_\_.
50. "In bridges, HSC is used". Is it (TRUE / FALSE)?

# **TESTS ON SELF-COMPACTING CONCRETE**

## **EXPERIMENT 1**

### **SLUMP CONE TEST**

#### **AIM:**

The slump flow test is used to determine assess the horizontal free flow of self-compacting concrete in the absence of obstructions.

#### **APPARATUS:**

1. Mould in the shape of a truncated cone with the internal dimensions 200 mm diameter at the base, 100mm diameter at the top and a height of 300 mm.
2. Base plate of a stiff non-absorbing material, at least 700mm square, marked with a circle
3. marking the central location for the slump cone, and a further concentric circle of 500mm diameter
4. Trowel
5. Scoop
6. Ruler
7. Stopwatch(optional).

#### **PROCEDURE:**

1. About 6 litres of concrete is needed to perform the test, sampled normally. Moisten the base plate and inside of slump cone, place base plate on level stable ground and the slump cone centrally on the base plate and hold down firmly.
2. Fill the cone with the scoop. Do not tamp, simply strike off the concrete level with the top of the cone with the trowel.
3. Remove any surplus concrete from around the base of the cone. Raise the cone vertically and allow the concrete to flow out freely.
4. Simultaneously, start the stopwatch and record the time taken for the concrete to reach the 00mm spread circle (This is the T50 time). floatable test, might be appropriate.
5. The T50 time is secondary indication of flow. A lower time indicates greater flow ability. The Brite EuRam research suggested that a time of 3-7 seconds is acceptable for civil engineering applications, and 2-5 seconds for housing applications.
6. In case of severe segregation most coarse aggregate will remain in the centre of the pool of concrete and mortar and cement paste at the concrete periphery. In case of minor segregation, a border of mortar without coarse aggregate can occur at the edge of the pool of concrete. If none of these phenomena appear it is no assurance that segregation will not occur since this is a time related aspect that can occur after a longer period.

#### **RESULT:**

Slump for the given sample = \_\_\_\_\_ mm

## VIVA:

1. A slump of 50-100mm can be used for\_\_\_\_\_.
2. Concrete is filled in how many layers in slump cone in slump test\_\_\_\_\_.
3. How many hoppers are there in compaction factor test?
4. What is the standard w/c value for nominal mix of concrete?
5. Slump value required for RCC Slab?
6. What is true slump?
7. Size of Concrete Cubes?
8. What are the dimensions of the slump cone?
9. List out workability tests?
10. How many strokes for each layer?
11. What is the slump value for low workability?
12. Slump value 100 – 175mm indicates\_\_\_\_\_workability.
13. What is zero slump?
14. What is collapsed slump?
15. What is shear slump?
16. What is segregation of concrete?
- 17.
18. What is the slump value for medium workability?
19. What is the slump value in inch for higher workability?
20. High strength concrete is defined purely on the basis \_\_\_\_\_
21. Use of HSC in column \_\_\_\_\_
22. Ultra-High Performance Concrete (UHPC), also known as \_\_\_\_\_
23. The material used for UHPC provides compressive strengths up to \_\_\_\_\_
24. The material used for UHPC provides flexural strengths up to \_\_\_\_\_
25. Range of modulus of elasticity for UHPC \_\_\_\_\_
26. What is the compressive strength for UHPC?
27. “Where the matrix is extremely dense, a weak aggregate may become the weak”. Is this statement true or false?
28. What is the percentage of water by weight in UHPC?
29. What is the percentage of PC by weight in UHPC?
30. What is the percentage of steel fibre by weight in UHPC?
31. What is the percentage of accelerator by weight in UHPC?
32. Creep is \_\_\_\_\_
33. If creep effect is considered at a given load, the modulus determined is referred to as \_\_\_\_\_
34. If  $\theta$  is creep coefficient then what is  $E_{long}$ ?
35. Concrete exhibits initial elastic strain which depends on \_\_\_\_\_
36. This strain increases over time due to \_\_\_\_\_
37. If the stress is removed, the specimen shows an instantaneous recovery strain\_\_\_\_\_the elastic strain on loading.
38. According to Lamond and Pielert, it's the\_\_\_\_\_that exhibits creep upon application of load on a concrete specimen.
39. When concrete is loaded it experiences a large strain upon loading known as \_\_\_\_\_.
40. Aggregate has therefore a direct effect on the long-term deformations of concrete because \_\_\_\_\_



41. Creep \_\_\_\_\_ as the age of application of load \_\_\_\_\_
42. The \_\_\_\_\_ the aggregate, the \_\_\_\_\_ is the magnitude of creep.
43. The \_\_\_\_\_ the modulus of elasticity the \_\_\_\_\_ is the creep.
44. A \_\_\_\_\_ paste structure undergoes \_\_\_\_\_ creep.
45. Creep is \_\_\_\_\_ to the strength of concrete.
46. The rate of creep rapidly \_\_\_\_\_ with time.
47. Aggregates with moisture movement and \_\_\_\_\_ elastic modulus cause a \_\_\_\_\_ amount of creep.
48. The rate of creep generally \_\_\_\_\_ with the \_\_\_\_\_ of the size of aggregates.
49. What is elastic strains?
50. Static modulus of elasticity of concrete has been related to its

## EXPERIMENT 2

### V - FUNNEL TEST

#### AIM:

The described V-funnel test is used to determine the filling ability (flowability) of the concrete with a maximum aggregate size of 20mm.

#### APPARATUS:

V-funnel, Bucket ( $\pm$  12 litre), Trowel, Scoop, Stopwatch.

#### INTRODUCTION:

Though the test is designed to measure flowability, the result is affected by concrete properties other than flow. The inverted cone shape will cause any liability of the concrete to block to be reflected in the result if, for example there is too much coarse aggregate. High flow time can also be associated with low deformability due to a high paste viscosity, and with high inter-particle friction. While the apparatus is simple, the effect of the angle of the funnel and the wall effect on the flow of concrete is not clear.

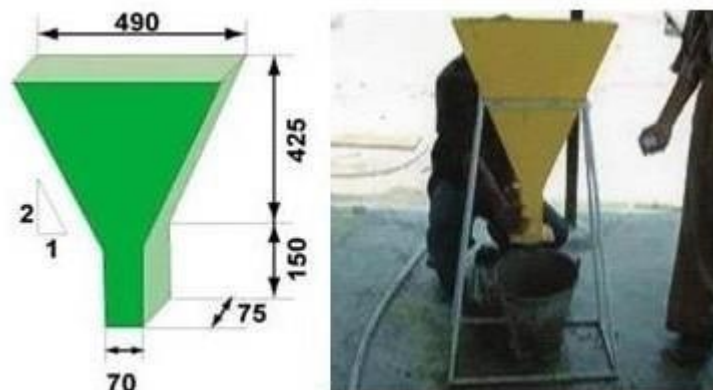

#### PROCEDURE:

1. About 12 litres of concrete is needed to perform the test, sampled normally. Set the V-funnel on firm ground. Moisten the inside surface of the funnel. Keep the trapdoor to allow any surplus water to drain. Close the trap door and place a bucket underneath.
2. Fill the apparatus completely with the concrete without compacting or tamping; simply strike off the concrete level with the top with the trowel.
3. Open within 10 secs after filling the trap door and allow the concrete to flow out under gravity. Start the stopwatch when the trap door is opened, and record the time for the complete discharge (the flow time). This is taken to be when light is seen from above through the funnel. The whole test has to be performed within 5 minutes.
4. Do not clean or moisten the inside surface of the funnel gain. Close the trapdoor and refill the V-funnel immediately after measuring the flow time. Place a bucket underneath.

5. Fill the apparatus completely with concrete without compacting or tapping, simply strike off the concrete level with the top with the trowel.
6. Open the trapdoor 5 minutes after the second fill of the funnel and allow the concrete to flow out under gravity.
7. Simultaneously start the stopwatch when the trap door is opened and record the time discharge to complete flow (the flow time at T5 minutes). This is to be taken when light is seen from above through the funnel.
8. For SCC a flow time of 10 seconds is considered appropriate.

**RESULT:**

The time of flow \_\_\_\_\_ seconds.

**VIVA:**

1. What is the aim of conducting V – Funnel test?
2. What is the amount of concrete is required for this experiment?
3. What is the Vee-Bee time for medium degree of workability?
4. Which test used for fibre reinforced concrete?
5. What are the precautions to be taken?
6. What should be the flow time for self-compacting concrete?
7. A compaction factor of .85 for a cement concrete sample indicates \_\_\_\_\_
8. How many types of tests are there to find workability?
9. What are the factors influencing the choice of mix proportions?
10. State the importance of the experiment?
11. What is the role of water in fresh concrete?
12. Describe the field method for assessing the workability.
13. Explain the significance of w/c ratio.
14. Discuss the factors affecting workability of concrete.
15. Explain any two tests for determining the workability of concrete?
16. How to calculate the percentage of flow?
17. Slump value required for RCC Slab?
18. What is the limitations of this test?
19. Size of cube used for testing of Compression Strength of Cement?
20. Plasticizers are used for?
21. A slump of 50-100mm can be used for \_\_\_\_\_.
22. Concrete is filled in how many layers in slump cone in slump test \_\_\_\_\_.
23. How many hoppers are there in compaction factor test?
24. What is the standard w/c value for nominal mix of concrete?
25. Slump value required for RCC Slab?
26. What is true slump?
27. Size of Concrete Cubes?
28. What are the dimensions of the slump cone?
29. List out workability tests?
30. How many strokes for each layer?
31. What is the slump value for low workability?
32. Slump value 100 – 175mm indicates \_\_\_\_\_workability.
33. What is zero slump?

34. What is collapsed slump?
35. What is shear slump?
36. What is segregation of concrete?
- 37.
38. What is the slump value for medium workability?
39. What is the slump value in inch for higher workability?
40. High strength concrete is defined purely on the basis\_\_\_\_\_.
41. For high-strength concrete, a cement should produce a minimum 7-days mortar-cube strength of approximately\_\_\_\_MPa.
42. \_\_\_\_\_mm nominal maximum size aggregates gives optimum strength.
43. Due to low w/c ratio\_\_\_\_\_.
44. What could be the possible answer among the following for compressive strength of high strength concrete?
45. What could be the possible answer among the following for water cement ratio for high strength concrete?
46. Due to low w/c ratio \_\_\_\_\_
47. Which type of aggregates are used to produce 70MPa compressive strength?
48. Maximum size of aggregates are used to produce 70MPa compressive strength is \_\_\_\_\_
49. Maximum size of aggregates are used to produce 100MPa compressive strength is \_\_\_\_\_
50. "In bridges, HSC is used". Is it (TRUE / FALSE)?

## EXPERIMENT 3

### L - BOX TEST

#### AIM:

To determine the workability or consistency of concrete mix.

#### APPARATUS:

L box of a stiff non-absorbing material, Trowel, Scoop, Stopwatch.

#### INTRODUCTION:

This test for self-compacting concrete is based on a Japanese design for underwater concrete, has been described by Peterson. The test assesses the flow of the concrete and also the extent to which it is subjected to blocking by reinforcement. The apparatus consists of rectangular section box in the shape of an „L“, with a vertical and horizontal section, separated by a movable gate, in front of which vertical length of reinforcement bar are fitted. The vertical section is filled with concrete, and then the gate lifted to let the concrete flow into the horizontal section.

When the flow has stopped, the height of the concrete at the end of the horizontal section is expressed as a proportion of that remaining in the vertical section. It indicates the slope of the concrete when at rest. This is an indication passing ability, or the degree to which the passage of concrete through the bars is restricted.

The horizontal section of the box can be marked at 200mm and 400mm from the gate and the times taken to reach these points measured. These are known as the T20 and T40 times and are an indication for the filling ability.

The section of bar can be of different diameters and are spaced at different intervals, in accordance with normal reinforcement considerations, 3x the maximum aggregate size might be appropriate. The bar can principally be set at any spacing to impose a more or less severe test of the passing ability of the concrete.

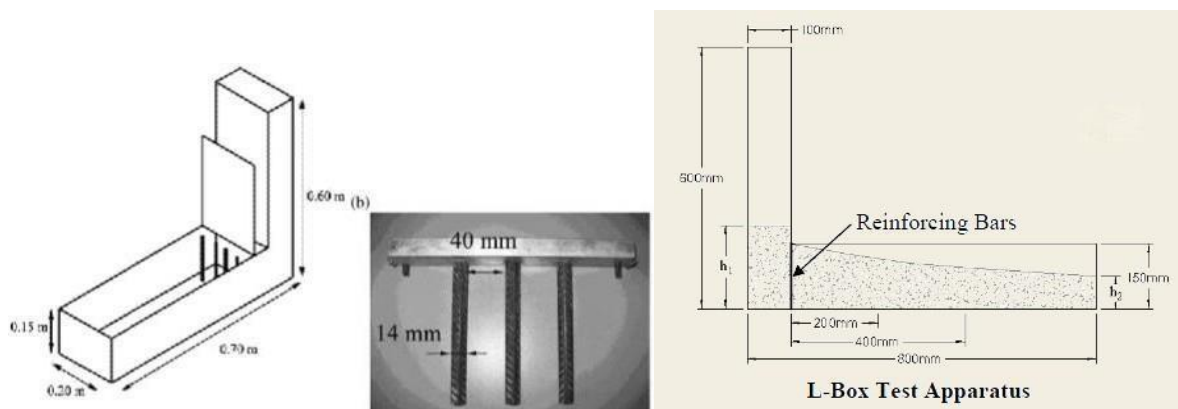

## **PROCEDURE:**

1. About 14 litres of concrete needed to perform the test, sampled normally. Set the apparatus level on firm ground, ensure that the sliding gate can open freely and then close it.
2. Moisten the inside surface of the apparatus, remove any surplus water, fill the vertical section of the apparatus with the concrete sample.
3. Leave it stand for 1 minute. Lift the sliding gate and allow the concrete to flow out into the horizontal section. Simultaneously, start the stopwatch and record the time for the concrete to reach the concrete 200 and 400 marks.
4. When the concrete stops flowing, the distances „H1“ and „H2“ are measured. Calculate  $H2/H1$ , the blocking ratio. The whole has to be performed within 5 minutes.

## **RESULT:**

1. If the concrete flows as freely as water, at rest it will be horizontal, so  $H2/H1=1$ .
2. Therefore, the nearest this test value, the „blocking ratio“, is unity, the better the flow of concrete.
3. The EU research team suggested a minimum acceptable value of 0.8. T20 and T40 time can give some indication of ease of flow, but no suitable values have been generally agreed. Obvious blocking of coarse aggregate behind the reinforcement bars can be detected visually.

## **VIVA:**

1. What is the aim of the experiment?
2. What are the limitations of the experiment?
3. What is the significance of conducting the experiment?
4. Workability can be resolved \_\_\_\_\_.
5. How to improve the workability of concrete?
6. What is workability?
7. What is workability?
8. List the tests for workability of concrete?
9. What are the dimensions of the L – Box?
10. What type of concrete need this test?
11. How much amount of concrete is required for this test?
12. What is blocking ratio?
13. For which grade of concrete this experiment is suitable?
14. Mention the size of coarse aggregate to be used?
15. Is robo sand is suitable for the mix (True / false).
16. The water should be free from salts and alkalies (True / False).
17. What is the size of fine aggregate to be used?
18. Mention the size of reinforcing bars?
19. How many bars to be provided in the L - Box?
20. What is the width of the L – Box?
21. What is plastic shrinkage?
22. How many types of shrinkages, caused due to cooling and carbonation?
23. What is drying shrinkage?

24. What is autogenous shrinkage?
25. What is carbonation shrinkage?
26. ACI 305.R.91 specifies Evaporation rate \_\_\_kg/hr/m<sup>2</sup> should be avoided to prevent plastic cracking.
27. Carbonic Acid + Ca(OH)<sub>2</sub> ⇌ X. What is the main compound in X?
28. If there is continuous supply of H<sub>2</sub>O to the concrete during hydration, concrete expands due to absorption of water by the cement gel. Is it (TRU / FALSE)?
29. Reduction in the volume due to shrinkage causes \_\_\_\_\_
30. It is observed that 14-34% of the 20 years shrinkage occurs in \_\_\_\_\_  
a) 2 weeks
31. It is observed that 40-80% of the 20 years shrinkage occurs in \_\_\_\_\_
32. It is observed that 66-85% of the 20 years shrinkage occurs in \_\_\_\_\_
33. "If the concrete is placed in 100% relative humidity for a length of time then there WON'T be any shrinkage". Is it true or false?
34. The magnitude of autogenous shrinkage is \_\_\_\_\_
35. Which aggregates have high shrinkage?
36. Which aggregates have low shrinkage?
37. The addition of a pozzolanic admixture such as fly ash reduces the \_\_\_\_\_
38. Lowering of \_\_\_\_\_ might also help, since this would reduce the amount of CH that forms.
39. When the \_\_\_\_\_ content is low, most ettringite will be formed in the plastic state.
40. The philosophy of prescribing low \_\_\_\_\_ cement to improve resistance to sulphate attack.
41. The quality of concrete, specifically a \_\_\_\_\_ permeability, is the best protection against sulphate attack.
42. For concrete exposed to a very aggressive environment the w/c should be lower than \_\_\_\_\_
43. The quality of concrete, specifically a \_\_\_\_\_ w/c ratio, is the best protection against sulphate attack.
44. The quality of concrete, specifically a \_\_\_\_\_ cement content, is the best protection against sulphate attack.
45. Concentration of water-soluble sulphates in water \_\_\_\_\_ ppm for mild exposure.
46. Concentration of water-soluble sulphates in water \_\_\_\_\_ ppm for severe exposure.
47. Which test used for low workable concretes?
48. \_\_\_\_\_ is practical in field test.
49. What is the Vee-Bee time for medium degree of workability?
50. What is the compaction factor for medium degree of workability?

## **4. TESTS ON HARDENED CONCRETE**



## **EXPERIMENT 1**

### **COMPRESSION TEST ON CUBES AND CYLINDERS**

#### **AIM:**

To determine the compressive strength of cubes and cylinders.

#### **APPARATUS:**

1. Moulds (cylinder mould of 150mm diameter and 300mm height, cube mould of 150mm X 150mm X 150mm),
2. Balance,
3. Compression testing m/c,
4. Mechanical vibrator etc.



**Compression test machine**

#### **INTRODUCTION:**

Compressive strength of concrete depends on many factors such as water-cement ratio, cement strength, quality of concrete material, quality control during production of concrete etc.

Test for compressive strength is carried out either on cube or cylinder. Concrete is strong in compression and weak in tension.

#### **PROCEDURE:**

##### **MIXING OF CONCRETE FOR CUBE TEST:**

Mix the concrete either by hand or in a laboratory batch mixer.

##### **HAND MIXING:**

1. Mix the cement and fine aggregate on a water tight none-absorbent platform until the mixture is thoroughly blended and is of uniform colour
2. Add the coarse aggregate and mix with cement and fine aggregate until the coarse aggregate is uniformly distributed throughout the batch

3. Add water and mix it until the concrete appears to be homogeneous and of the desired consistency.

#### **SAMPLING OF CUBES FOR TEST:**

1. Clean the moulds and apply oil
2. Fill the concrete in the moulds in layers approximately 5cm thick
3. Compact each layer with not less than 35 strokes per layer using a tamping rod (steel bar 16mm diameter and 60cm long, bullet pointed at lower end)
4. Level the top surface and smoothen it with a trowel.

#### **PRECAUTIONS FOR TESTS:**

The water for curing should be tested every 7 days and the temperature of water must be at  $27 \pm 2^{\circ}\text{C}$ .

#### **PROCEDURE FOR CUBE TEST:**

1. Remove the specimen from water after specified curing time and wipe out excess water from the surface.
2. Take the dimension of the specimen to the nearest 0.2m
3. Clean the bearing surface of the testing machine
4. Place the specimen in the machine in such a manner that the load shall be applied to the opposite sides of the cube cast.
5. Align the specimen centrally on the base plate of the machine.
6. Rotate the movable portion gently by hand so that it touches the top surface of the specimen.
7. Apply the load gradually without shock and continuously at the rate of  $140 \text{ kg/cm}^2/\text{minute}$  till the specimen fails
8. Record the maximum load and note any unusual features in the type of failure.

#### **PROCEDURE FOR CYLINDER TEST:**

1. Cast the cylinder and cure for 28 days.
2. Takeout the specimen from the curing tank.
3. Wipe out the excess water from the surface of specimen.
4. Place the specimen vertically on the platform of compression testing machine.
5. Apply the load continuously and uniformly without shock at the rate of 315 kn/min. And continue the loading until the specimen fails.
6. Record the maximum load taken.

<b>S.NO</b>	<b>DAYS AFTER CASTING</b>	<b>STRENGTH GAIN %</b>
1	1 DAYS	16
2	3 DAYS	40
3	7 DAYS	65
4	14 DAYS	90
5	28 DAYS	99

**COMPRESSIVE STRENGTH OF DIFFERENT GRADES OF CONCRETE AT 7 AND 28 DAYS:**

GRADE OF CONCRETE	MINIMUM COMPRESSIVE STRENGTH N/MM <sup>2</sup> AT 7 DAYS	SPECIFIED CHARACTERISTIC COMPRESSIVE STRENGTH (N/MM <sup>2</sup> ) AT 28 DAYS
M 15	10	15
M 20	13.5	20
M 25	17	25
M 30	20	30
M 35	23.5	35
M 40	27	40

**OBSERVATION:**

Dimension of the cube: 150mm X 150mm X 150mm

S.NO	Compressive strength of cement = (Load at failure)/ (Cross- Sectional area)
1	
2	
3	

**CALCULATION FOR CUBE TESTING:**

Size of the cube = 15cm x 15cm x 15cm

Area of the specimen (calculated from the mean size of the specimen) = 225 cm<sup>2</sup>.

Characteristic compressive strength ( $f_{ck}$ ) at 7 days = \_\_\_\_\_.

Expected maximum load =  $f_{ck} \times \text{area} \times f.s$

Range to be selected is \_\_\_\_\_.

Similar calculation should be done for 28 days compressive strength

Maximum load applied = \_\_\_\_\_ tones = \_\_\_\_\_ N.

Compressive strength = (Load in N/ Area in mm<sup>2</sup>) = \_\_\_\_\_ N/mm<sup>2</sup>.

**CALCULATIONS FOR CYLINDER TEST:**

Range Calculation

Characteristic compressive strength at 28 days = N/ mm<sup>2</sup>

Area of cross section =  $\pi \times d^2$

Expected load = stress x area x f.s =

Range to be selected is \_\_\_\_\_.

**RESULT:**

Average compressive strength of the concrete cube = \_\_\_\_\_ N/ mm<sup>2</sup> (at 7 days)

Average compressive strength of the concrete cube = \_\_\_\_\_ N/mm<sup>2</sup> (at 28 days).

Average compressive strength of the concrete cylinder = \_\_\_\_\_ N/ mm<sup>2</sup> (at 7 days)

Average compressive strength of the concrete cylinder = \_\_\_\_\_ N/mm<sup>2</sup> (at 28 days).

**EXAMPLE:**

Compressive Strength of Concrete Cubes & cylinders – Lab Test & Procedure

**PROCEDURE:**

**CUBE CASTING:**

1. Measure the dry proportion of ingredients (Cement, Sand & Coarse Aggregate) as per the design requirements. The Ingredients should be sufficient enough to cast test cubes.
2. Thoroughly mix the dry ingredients to obtain the uniform mixture.
3. Add design quantity of water to the dry proportion (water-cement ratio) and mix well to obtain uniform texture.
4. Fill the concrete to the mould with the help of vibrator for thorough compaction.
5. Finish the top of the concrete by trowel & tapped well till the cement slurry comes to the top of the cubes.

**CURING:**

1. After some time, the mould should be covered with red gunny bag and put undisturbed for 24 hours at a temperature of 27 ° Celsius ± 2.
2. After 24 hours remove the specimen from the mould.
3. Keep the specimen submerged under fresh water at 27 ° Celsius. The specimen should be kept for 7 or 28 days. Every 7 days the water should be renewed.
4. The specimen should be removed from the water 30 minutes prior to the testing.
5. The specimen should be in dry condition before conducting the testing.
6. The Cube weight should not be less than 8.1 Kgs

**TESTING:**

1. Now place the concrete cubes into the testing machine. (centrally).
2. The cubes should be placed correctly on the machine plate (check the circle marks on the machine). Carefully align the specimen with the spherically seated plate.
3. The load will be applied to the specimen axially.
4. Now slowly apply the load at the rate of 140kg/cm<sup>2</sup> per minute till the cube collapse.

5. The maximum load at which the specimen breaks is taken as a compressive load.

### CALCULATION:

Compressive Strength of concrete = Maximum compressive load / Cross Sectional Area

### VIVA:

1. In Charpy test specimen, the angle of v-notch section is \_\_\_\_\_.
2. For hardness test of copper in Brinell hardness tester, the diameter of ball is \_\_\_\_\_.
3. During compression test of cast iron, the failure occurs i.e. the crack appears along the \_\_\_\_\_.
4. The property of a material that resists penetration or indentation by means of abrasion or scratching is known as \_\_\_\_\_.
5. The indenter used in Brinell hardness test is a \_\_\_\_\_.
6. The ability of the material to resist stress without failure is called \_\_\_\_\_.
7. “The shape of specimen used in compression test is Cube and cylinder” \_\_\_\_\_.
8. Equipment used to test Compression Strength of Concrete?
9. Size of Concrete Cubes?
10. No. of Cube samples required for testing Compression Strength for 100 m<sup>3</sup> of concrete?
11. List the various methods of compacting of concrete?
12. How is compressive strength of concrete is measured?
13. What should be the compressive strength of concrete at 7 days?
14. What is  $F_{ck}$  of concrete?
15. What is the compressive strength of M<sub>30</sub> grade concrete?
16. How long does it take to concrete to reach its full strength?
17. What should be the compressive strength of concrete at 14 days?
18. What should be the compressive strength of concrete at 28 days?
19. What is standard deviation for M<sub>40</sub> grade?
20. What happens if we test a wet cube in a compressive strength test machine?
21. Tensile test can be performed on \_\_\_\_\_.
22. Which machine records the change in length of specimen?
23. The ability of the material to resist stress without failure is called \_\_\_\_\_.
24. In universal testing machine, for a circular section specimen, the gauge length is taken to be \_\_\_\_\_.
25. “The shape of specimen used in compression test is Cube and cylinder”.
26. During compression test of cast iron, the failure occurs i.e. the crack appears along the \_\_\_\_\_.
27. The property of a material that resists penetration or indentation by means of abrasion or scratching is known as \_\_\_\_\_.
28. The indenter used in Brinell hardness test is a \_\_\_\_\_.
29. For hardness test of copper in Brinell hardness tester, the diameter of ball is \_\_\_\_\_.

- 30.3 In Charpy test specimen, the angle of v-notch section is \_\_\_\_\_
- 31.3 The breaking up of cohesion in a mass of concrete is called \_\_\_\_\_
- 32.3 The separation of water or water-cement mixture from the freshly mixed concrete is known as bleeding.
33. The continuous strain, which the concrete undergoes due to application of external loads, is called \_\_\_\_\_
34. Harshness in concrete is due to the excess of \_\_\_\_\_
35. In order to avoid segregation, the concrete should not be thrown from a height (TRUE / FALSE)
36. Reinforced cement concrete is equally strong in taking \_\_\_\_\_
37. Plain cement concrete is strong in taking \_\_\_\_\_
38. How many types of sulphates attack occur in concrete?
39. What is internal sulphates attack?
40. What is internal sulphates attack?
41. What is flexural strength?
42. What is equivalent flexural load?
43. What is equivalent flexural strength?
44. What is equivalent flexural strength ratio?
45. Calipers, capable of reading the dimensions of test specimens to an accuracy of \_\_\_\_\_
- 46.4 Rule (ruler/scale), capable of reading the dimensions of test specimens to an accuracy of \_\_\_\_\_
- 47.4 Load measuring device shall be capable of measuring loads to an accuracy of \_\_\_\_\_
- 48.4 The tolerances on the cross-section of the test specimens shall be within  $\pm$  \_\_\_\_\_
- 49.4 The flexural strength (or modulus of rupture) is obtained for the first peak load,  $P_{max}$  as: \_\_\_\_\_
- 50.5 A data acquisition system capable of digitally recording and storing load and deflection data at least \_\_\_\_\_

## EXPERIMENT 2

### FLEXURE TEST

#### AIM:

To determine the Flexural Strength of Concrete, which comes into play when a road slab with inadequate sub-grade support is subjected to wheel loads and / or there are volume changes due to temperature / shrinking.

#### APPARATUS:

Beam mould of size 15 x 15x 70 cm, Tamping bar, Flexural test machine.

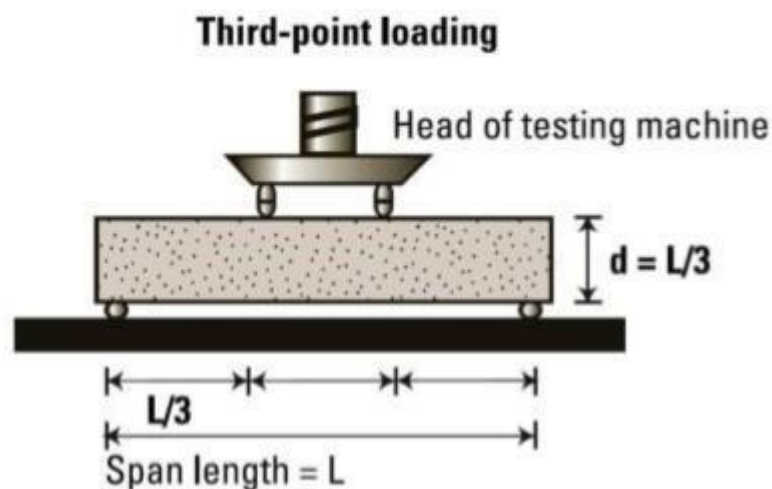

#### PROCEDURE:

1. Prepare the test specimen by filling the concrete into the mould in 3 layers of approximately equal thickness.
2. Tamp each layer 35 times using the tamping bar as specified above. Tamping should be distributed uniformly over the entire cross-section of the beam mould and throughout the depth of each layer.
3. Clean the bearing surfaces of the supporting and loading rollers, and remove any loose sand or other material from the surfaces of the specimen where they are to make contact with the rollers.
4. Circular rollers manufactured out of steel having cross section with diameter 38 mm will be used for providing support and loading points to the specimens. The length of the rollers shall be at least 10 mm more than the width of the test specimen. A total of four rollers shall be used, three out of which shall be capable of rotating along their own axes. The distance between the outer rollers (i.e. span) shall be  $3d$  and the distance between the inner rollers shall be  $d$ . The inner rollers shall be equally spaced between the outer rollers, such that the entire system is systematic.
5. The specimen stored in water shall be tested immediately on removal from water; whilst they are still wet. The test specimen shall be placed in the machine correctly centred with

the longitudinal axis of the specimen at right angles to the rollers. For moulded specimens, the mould filling direction shall be normal to the direction of loading.

6. The load shall be applied at a rate of loading of 400 kg/min for the 15.0 cm specimens and at a rate of 180 kg/min for the 10.0 cm specimens.

**CALCULATION:**

The Flexural Strength or modulus of rupture ( $f_b$ ) is given by

$$f_b = pl/bd^2$$

(when  $a > 20.0\text{cm}$  for 15.0cm specimen or  $> 13.0\text{cm}$  for 10cm specimen)

or

$$f_b = 3pa/bd^2$$

(when  $a < 20.0\text{cm}$  but  $> 17.0$  for 15.0cm specimen or  $< 13.3 \text{ cm}$  but  $> 11.0\text{cm}$  for 10.0cm specimen.)

Where,

$a$  = the distance between the line of fracture and the nearer support, measured on the center line of the tensile side of the specimen

$b$  = width of specimen (cm)

$d$  = failure point depth (cm)

$l$  = supported length (cm)

$p$  = max. Load (kg)

**RESULT:**

The Flexural strength of the concrete is reported\_\_\_\_\_.

**VIVA:**

1. What is flexural strength?
2. What is equivalent flexural load?
3. What is equivalent flexural strength?
4. What is equivalent flexural strength ratio?
5. Callipers, capable of reading the dimensions of test specimens to an accuracy of \_\_\_\_\_.
6. Rule (ruler/scale), capable of reading the dimensions of test specimens to an accuracy of \_\_\_\_\_.
7. Load measuring device shall be capable of measuring loads to an accuracy of \_\_\_\_\_.
8. The tolerances on the cross-section of the test specimens shall be within  $\pm$  \_\_\_\_\_.



9. The flexural strength (or modulus of rupture) is obtained for the first peak load,  $P_{max}$  as \_\_\_\_\_.
10. A data acquisition system capable of digitally recording and storing load and deflection data at least \_\_\_\_\_.
11. Tensile test can be performed on \_\_\_\_\_
12. Which machine records the change in length of specimen?
13. How the flexural strength is calculated?
14. What are the precautions to be taken while place the specimen?
15. What are the standard dimensions of the beam mould?
16. Differentiate between three-point loading and two-point loading?
17. Concrete weak in tension and strong in compression (True / False).
18. What is the aim of the experiment?
19. What the load to be applied at 15cms?
20. What is the line of fracture?
21. What is flexural strength?
22. What is equivalent flexural load?
23. What is equivalent flexural strength?
24. What is equivalent flexural strength ratio?
25. Calipers, capable of reading the dimensions of test specimens to an accuracy of \_\_\_\_\_
- 26.2Rule (ruler/scale), capable of reading the dimensions of test specimens to an accuracy of \_\_\_\_\_
- 27.2Load measuring device shall be capable of measuring loads to an accuracy of \_\_\_\_\_
- 28.2The tolerances on the cross-section of the test specimens shall be within  $\pm$  \_\_\_\_\_
- 29.2The flexural strength (or modulus of rupture) is obtained for the first peak load,  $P_{max}$  as: \_\_\_\_\_
- 30.3A data acquisition system capable of digitally recording and storing load and deflection data at least \_\_\_\_\_
- 31.3The slump would not exceed 50 mm when compacting concrete with vibrators (TRUE / FALSE).
32. When vibrators are used for compaction, the consistency of concrete depends upon the \_\_\_\_\_
- 33.3The vibrator should not be immersed through a full depth of freshly laid concrete (TRUE / FALSE).
34. The levelling operation that removes humps and hollows and give a true, uniform concrete surface is called \_\_\_\_\_
35. The final operation of finishing the concrete surface is called \_\_\_\_\_
36. The process of removing the irregularities from the surface of concrete left after screeding is called floating.
37. The process of hardening the concrete mixes by keeping its surface moist for a certain period is called \_\_\_\_\_
38. After the curing of 28 days, the concrete gains strength upto \_\_\_\_\_
39. The construction joints in cement concrete \_\_\_\_\_
40. For compacting large sections of mass concrete in structures, the type of vibrator used is \_\_\_\_\_.
41. In Charpy test specimen, the angle of v-notch section is \_\_\_\_\_.

42. For hardness test of copper in Brinell hardness tester, the diameter of ball is \_\_\_\_\_
43. During compression test of cast iron, the failure occurs i.e. the crack appears along the \_\_\_\_\_
44. The property of a material that resists penetration or indentation by means of abrasion or scratching is known as \_\_\_\_\_
45. The indenter used in Brinell hardness test is a \_\_\_\_\_
46. The ability of the material to resist stress without failure is called \_\_\_\_\_
47. “The shape of specimen used in compression test is Cube and cylinder”  
\_\_\_\_\_.
48. Equipment used to test Compression Strength of Concrete?
49. Size of Concrete Cubes?
50. No. of Cube samples required for testing Compression Strength for 100 m<sup>3</sup> of concrete?

## **EXPERIMENT 3**

### **SPLITTING TENSILE TEST**

#### **AIM:**

This method covers the determination of the splitting tensile strength of cylindrical concrete specimens.

#### **APPARATUS:**

Compression testing machine, two packing strips of plywood 30 cm long and 12mm wide.



#### **PROCEDURE:**

1. Take the wet specimen from water after 7 days of curing
2. Wipe out water from the surface of specimen
3. Draw diametrical lines on the two ends of the specimen to ensure that they are on the same axial place.
4. Note the weight and dimension of the specimen.
5. Set the compression testing machine for the required range.
6. Keep are plywood strip on the lower plate and place the specimen.
7. Align the specimen so that the lines marked on the ends are vertical and centred over the bottom plate.
8. Place the other plywood strip above the specimen.
9. Bring down the upper plate to touch the plywood strip.
10. Apply the load continuously without shock at a rate of approximately 1421kg/cm<sup>2</sup>/minute (Which corresponds to a total load of 9900kg/minute to 14850kg/minute).
11. Note down the breaking load(P).

## CALCULATIONS:

As per IS456, split tensile strength of concrete. =  $0.7f_{ck}$ .

The splitting tensile strength is calculated using the formula

$$T_{sp} = \frac{2P}{\pi DL}$$

Where P = applied load  
D = diameter of the specimen  
L = length of the specimen

$$\text{Therefore } P = T_{sp} \times \pi DL/2$$

$$\text{Expected load} = P \times f.s$$

$$\text{Split tensile strength } T = \frac{2P}{\pi DL}$$

## RESULT:

Splitting tensile strength of given concrete = \_\_\_\_\_ N/mm<sup>2</sup>.

## VIVA:

1. What is the importance of conducting the experiment?
2. What are the precautions to be taken?
3. What is split tensile strength?
4. What are the limitations?
5. What happens if the wet specimen is tested?
6. How the splitting tensile strength is calculated?
7. Differentiate the flexural strength and split tensile strength?
8. What are the standard split tensile strength for the M30 grade of concrete?
9. Differentiate between three-point loading and two-point loading?
10. What are the standard dimensions of the cylinder mould?
11. What is the % of strength when the specimen is tested for 7 days?
12. What is standard deviation?
13. How much load should be applied continuously on the specimen?
14. Load measuring device shall be capable of measuring loads to an accuracy of \_\_\_\_\_.
15. The flexural strength (or modulus of rupture) is obtained for the first peak load,  $P_{max}$  as \_\_\_\_\_.
16. A data acquisition system capable of digitally recording and storing load and deflection data at least \_\_\_\_\_.
17. Callipers, capable of reading the dimensions of test specimens to an accuracy of \_\_\_\_\_.
18. Rule (ruler/scale), capable of reading the dimensions of test specimens to an accuracy of \_\_\_\_\_.
19. How many strokes to be given for each layer?
20. Why the oil layer is applied to the mould?
21. Generally what is the w/c ratio?

22. The slump would not exceed 50 mm when compacting concrete with vibrators (TRUE / FALSE)
23. The levelling operation that removes humps and hollows and give a true, uniform concrete surface is called \_\_\_\_\_
24. What is the limitation of plasticizers?
25. What is the allowed reduction of water with super plasticizers without reducing workability?
26. A lower ratio leads to \_\_\_\_\_
27. Silica fume is \_\_\_\_\_
28. Content of SiO<sub>2</sub> in silica fume?
29. What is the content of Al<sub>2</sub>O<sub>3</sub> in fly ash?
30. Find the odd one out.
  - a) Water reducing plasticizers
  - b) Water reducing plasticizers
  - c) High performance plasticizers
  - d) Super plasticizers
31. Which machine is preferred for abrasion test?
32. A maximum value of \_\_\_\_\_percent is allowed for WBM base course in Indian conditions.
33. Aggregates to be used for wearing course, the impact value shouldn't exceed \_\_\_\_\_percent.
34. What is the range of water absorption of aggregates used in road?
35. The loss in weight should not exceed \_\_\_\_\_percent when tested with sodium sulphate and \_\_\_\_\_percent with magnesium sulphate solution.
36. If 60% aggregates doesn't pass through the 2.36mm sieve, then what would be the value of Aggregate impact value?
37. What C31 test under Standard ASTM test method?
38. What C39 test under Standard ASTM test method?
39. What C138 test under Standard ASTM test method?
40. What C143 test under Standard ASTM test method?
41. What C172 test under Standard ASTM test method?
42. What C173 test under Standard ASTM test method?
43. The \_\_\_\_\_compressive strength required from structural consideration.
44. The adequate workability necessary for \_\_\_\_\_compaction with the compacting equipment available.
45. \_\_\_\_\_water-cement ratio content to give adequate durability for the particular site conditions.
46. \_\_\_\_\_cement content to avoid shrinkage cracking due to temperature cycle in mass concrete.
47. \_\_\_\_\_has designated the concrete mixes into a number of grades as M10, M15.
48. What is the approx. mix proportion for M10?
49. What is the approx. mix proportion for M15?
50. What is the approx. mix proportion for M20?

## **EXPERIMENT 4**

### **MODULUS OF ELASTICITY**

#### **AIM:**

To determine the modulus of elasticity of concrete.

#### **APPARATUS:**

Concrete calendar 15 cm diameter and 30cm long.

#### **PROCEDURE:**

1. Assemble the top and bottom frame by keeping the spacers in position.
2. Keep the pivot rod on the screws and lock them in position.
3. Keep the tightening screws of the bottom and top frame unscrewed (but not completely).
4. Place the specimen on a level surface.
5. Keep the compressometer centrally on the specimen so that the tightening screw of the bottom and top frame are at equal distance from the two ends.
6. Tighten the screws so that the compressometer is held on the specimen.
7. Remove the spacers by unscrewing the spacer screws.

#### **TESTING:**

1. Place the specimen with compressometer in the compression testing machine and centre it.
2. Apply load continuously without stock at a rate of 140 kg /cm<sup>2</sup>/minute until a stress of
3. (c+5) kg/cm<sup>2</sup> is reached where c is the one third of average compressive strength of cubes calculated to the nearest 5kg /cm<sup>2</sup> (a load of 12.4T)
4. Maintain the load at this stress for at least one minute and reduce gradually to an average stress of 1.5 kg/ cm<sup>2</sup>(a load of 0.3 T).
5. Apply the load again at the same rate until an average stress of (c+ 1.5) kg/cm<sup>2</sup> is reached (a load of 11.8T)
6. Note the compressometer reading at this load.
7. Reduce the load gradually and take readings at an interval of 1T up to 0.3T (11.8T,10.8T,9.8T,8.8T,7.8T, ..... ,1.8T,0.3T)
8. Apply load third time and note the compressometer readings at an interval of 1T (0.3T,1.8T,2.8T, ..... 11.8T).



### **CALCULATION:**

Initial tangent modulus = stress/ strain

(Take load & deflection from the initial tangent)

Tangent modulus at working stress = stress/ strain

(Take load and deflection from the tangent drawn at working stress)

Secant modulus = stress/strain

(Take load and deflection from the line joining initial point and the point at working stresses)

### **RESULT:**

1. Initial tangent modulus of given concrete = \_\_\_\_\_ N / mm<sup>2</sup>.
2. Tangent modulus at working stress = \_\_\_\_\_ N / mm<sup>2</sup>.
3. Secant modulus (Modulus of elasticity of given concrete) = \_\_\_\_\_ N / mm<sup>2</sup>

### **VIVA:**

1. What is modulus of elasticity?
2. What is the modulus of elasticity of steel?
3. What is the modulus of elasticity of concrete?
4. Why modulus of elasticity is important?
5. How do you complete the modulus of elasticity?
6. What is the aim of determining modulus of elasticity?
7. What is secant modulus?
8. What is initial tangent modulus?
9. What is tangent modulus?
10. What are the dimensions of concrete calendar?
11. What is stress?
12. What is strain?
13. What is the load to be applied continuously on the specimen?
14. How the modulus of elasticity is calculated?
15. What is young's modulus?
16. What is elasticity?

17. What is plasticity?
18. How do you compute the modulus of elasticity?
19. Is young's modulus is same as stiffness?
20. What is the formula for shear modulus?
21. What is the approx. mix proportion for M25?
22. Maximum nominal size of aggregates to be used in concrete may be as large as possible within the limits prescribed by \_\_\_\_\_
23. Durability of concrete is proportional to \_\_\_\_\_
24. Strength of concrete show an increase with \_\_\_\_\_
25. Strength of concrete is \_\_\_\_\_
26. As per & 5456:200 Young's modulus of concrete is \_\_\_\_\_
27. Strength of concrete is proportional to \_\_\_\_\_
28. Strength of concrete increase with \_\_\_\_\_
29. Strength of concrete increase with \_\_\_\_\_
30. Approximate ratio of the strength of the cement conc of 7 days to that of 28 days (2/3) \_\_\_\_\_.
31. Approximate ratio of strength of the 30 cm cube to that of 15 cm cube is \_\_\_\_\_
32. Approximate ratio of direct tensile strength to flexural strength is \_\_\_\_\_
33. For walls, columns and vertical faces of all structural members, the form work is generally removed after \_\_\_\_\_
34. The basic requirement for the success of any quality control plan is the availability of experienced, knowledgeable and trained personnel at all the levels. True or False.
- 35.3Quality control helps to \_\_\_\_\_the risks of overdesign that \_\_\_\_\_the overall cost.
36. \_\_\_\_\_cost of maintenance of the structure \_\_\_\_\_construction due to quality works.
37. It \_\_\_\_\_job-site concrete handling, and testing procedures to \_\_\_\_\_potential liability to the company.
38. \_\_\_\_\_quality construction \_\_\_\_\_the wastage of materials.
39. Quality management system improves perception of customers towards company. True or false
40. It opens the area of improvement for quality construction rationally based on the documents from \_\_\_\_\_projects.
41. The property of a material that resists penetration or indentation by means of abrasion or scratching is known as \_\_\_\_\_
42. During compression test of cast iron, the failure occurs i.e. the crack appears along the \_\_\_\_\_
43. What is the importance of conducting the experiment?
44. What are the precautions to be taken?
45. What is split tensile strength?
46. What are the limitations?
47. What happens if the wet specimen is tested?
48. How the splitting tensile strength is calculated?
49. Differentiate the flexural strength and split tensile strength?
50. What are the standard split tensile strength for the M30 grade of concrete?



## **5.NON-DESTRUCTIVE TEST OF CONCRETE**

## EXPERIMENT 1

### REBOUND HAMMER

#### AIM:

To determine the comprehensive strength of harden concrete by Rebound Hammer.

#### APPARATUS:

Rebound Hammer.

#### INTRODUCTION:

When the plunger of rebound hammer is pressed against the surface of the concrete, the spring controlled mass rebounds and the extent of such rebound depends upon the surface hardness of concrete. The surface hardness and therefore the rebound is taken to be related to the compressive strength of the concrete. The rebound is read off along a graduated scale and is designated as the rebound number or rebound index.

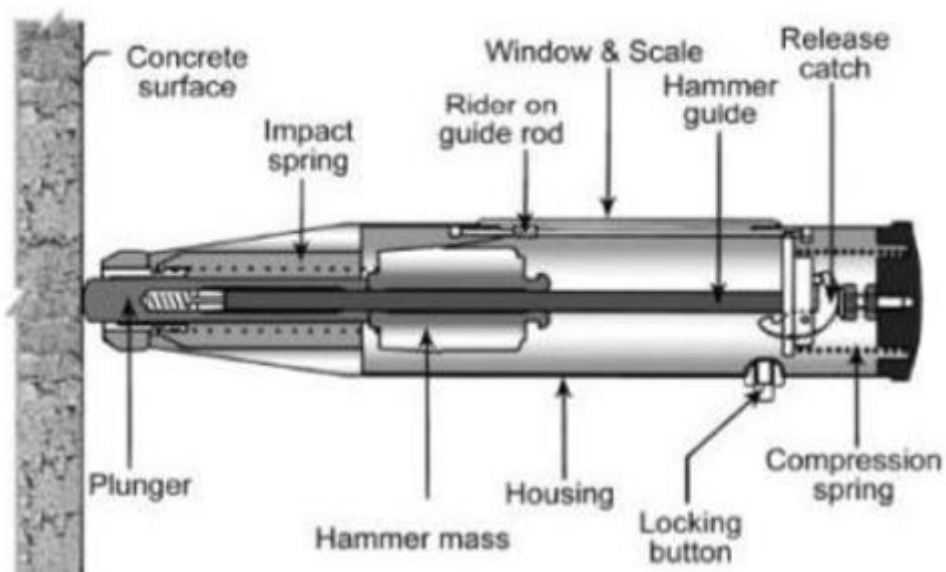

#### PROCEDURE:

1. Smoothen the concrete surface with the help of the carborundum stone removing any loosely adhered scale to the concrete surface.
2. Rough surfaces resulting from incomplete compaction, loss of grout, spalled or tooled surfaces do not give reliable results and should be avoided.
3. The point of impact should be at least 20 mm away from any edge or shape discontinuity.

4. The rebound hammer measurements can be taken at any angle, vertically upwards, downwards, horizontal, or any intermediate angle as the situation demands Six readings are taken about each point of observation and the average of these readings after deleting outliers becomes the rebound index for the point of observation.



**OBSERVATIONS:**

S.NO	REBOUND NUMBER (6 READINGS)	LOCATION OF OBSERVATIONS	COMPRESSIVE STRENGTH (KG/CM <sup>2</sup> )
1			
2			
3			

**RESULTS:**

Compressive strength of the harden concrete surface is\_\_\_\_\_.

**VIVA:**

1. What do you know about NDT?
2. List out various equipment used in NDT?
3. During radiography test, which region absorbs less radiation and transmits more?
4. Which test is used to determine dimensions of any object?
5. In which type of test the capillary action principle is used?
6. Which test can be performed without skilled labour?
7. What is non - destructive test?
8. What is destructive test?
9. An ultrasonic pulse velocity test is an\_\_\_\_\_.
10. In this test, the strength and quality of concrete or rock is assessed by measuring the \_\_\_\_\_of an ultrasonic pulse.
11. Higher velocities indicate\_\_\_\_\_.

12. Slower velocities may indicate \_\_\_\_\_
13. Mechanical pulse having an oscillation frequency in range of `\_\_\_\_\_.
14. The number of cycles per second is the definition of\_\_\_\_\_.
15. A discontinuity that occurs during the casting of molten metal which may be caused by the splashing, surging, interrupted pouring is\_\_\_\_\_.
16. When the motion of the particles of a medium are at right angles to the direction of wave motion, the wave being transmitted is called a\_\_\_\_\_.
17. A second name for compression wave is\_\_\_\_\_.
18. The interference field near the face of a transducer is often referred to as the \_\_\_\_\_.
19. What is the diameter of the plunger?
20. What is the importance of this experiment?
21. Which among the following is not a type of Non-destructive testing?
  - a) Compression test
  - b) Visual testing
  - c) Ultrasonic testing
  - d) Eddy current testing
22. What is non-destructive test?
23. Which test is used to determine dimensions of any object?
24. During radiography test, which region absorbs less radiation and transmits more?
25. Which of the following statements is/are true for ultrasonic test?
26. Which among the following is the last step in magnetic particle test method?
27. In which type of test the capillary action principle is used?
28. Which test can be performed without skilled labour?
29. What is the first step involved in the process of preparation of test sample of material?
30. Which of the following compound is used for fine polishing?
31. What is destructive test?
32. Identify the type of destructive testing.
33. Which test can be performed without skilled labor?
34. Compressive strength of hardened concrete is done by \_\_\_\_\_
35. It is about\_\_\_\_times the tensile stress determined by the splitting test.
36. A ratio of core height-to-diameter of\_\_\_\_gives a standard cylinder test.
37. In Concrete core test the strength is \_\_\_at the top and \_\_\_at the bottom.
38. What is nondestructive test?
39. During radiography test, which region absorbs less radiation and transmits more?
40. Which of the following compound is used for fine polishing?
  - a) Aluminum oxide
  - b) Nitric oxide
  - c) Silicon carbide
  - d) Iron oxide
41. How can we prevent cracks in concrete structures?
42. What is the maximum w/c ratio?
43. Which can be the possible option for cracking in the building?
44. Is it possible to have 0% crack in our building?
45. Plastic shrinkage cracking occurs in\_\_\_\_\_hours after placing.

46. Which one can't be the reason for the shrinkage of concrete?
47. Evaluation of cracks \_\_\_\_\_ be determined before cracking.
48. Evaluation of cracks \_\_\_\_\_ be determined after cracking.
49. Symptoms for acid attack?
50. Symptoms for aggressive water attack?

## EXPERIMENT 2

### ULTRASOUND PULSE VELOCITY (UPV)

#### AIM:

To determine the time of travel of an ultrasonic pulse passing through the concrete.

#### APPARATUS:

Ultrasound pulse velocity

#### INTRODUCTION:

This test is done to assess the quality of concrete by ultrasonic pulse velocity method as per IS: 13311 (Part 1) – 1992. The underlying principle of this test is – The method consists of measuring the time of travel of an ultrasonic pulse passing through the concrete being tested. Comparatively higher velocity is obtained when concrete quality is good in terms of density, uniformity, homogeneity etc.

#### PROCEDURE:

1. Preparing for use: Before switching on the „V“ meter, the transducers should be connected to the sockets marked “TRAN” and ” REC”. The „V“ meter may be operated with either:
  - a) the internal battery, b) an external battery or c) the A.C line.
2. Set reference: A reference bar is provided to check the instrument zero. The pulse time for the bar is engraved on it. Apply a smear of grease to the transducer faces before placing it on the opposite ends of the bar. Adjust the „SET REF“ control until the reference bar transit time is obtained on the instrument read-out.
3. Range selection: For maximum accuracy, it is recommended that the 0.1 microsecond range be selected for path length up to 400mm.
4. **Pulse velocity:** Having determined the most suitable test points on the material to be tested, make careful measurement of the path length „L“.
5. Apply couplant to the surfaces of the transducers and press it hard onto the surface of the material. Do not move the transducers while a reading is being taken, as this can generate noise signals and errors in measurements. Continue holding the transducers onto the surface of the material until a consistent reading appears on the display, which is the time in microsecond for the ultrasonic pulse to travel the distance „L“. The mean value of the display readings should be taken when the units digit hunts between two values.

$$\text{Pulse velocity} = (\text{Path length}/\text{Travel time}).$$

6. **Separation of transducer leads:** It is advisable to prevent the two transducer leads from coming into close contact with each other when the transit time measurements are being

taken. If this is not done, the receiver lead might pick-up unwanted signals from the transmitter lead and this would result in an incorrect display of the transit time.

**RESULT:**

The quality of concrete in terms of uniformity, incidence or absence of internal flaws, cracks and segregation, etc, indicative of the level of workmanship employed, can thus be assessed using the guidelines given below, which have been evolved for characterizing the quality of concrete in structures in terms of the ultrasonic pulse velocity.

<b>PULSE/VELOCITY (KM/SECOND)</b>	<b>CONCRETE QUALITY (GRADING)</b>
ABOVE 4.5	EXCELLENT
3.5 TO 4.5	GOOD
3.0 TO 3.5	MEDIUM
BELOW 3.0	DOUBTFUL

**VIVA:**

1. What are the types of destructive and non – destructive tests?
2. What are the different types of hardness tests are carried out?
3. What do you know about NDT?
4. List out various equipment used in NDT?
5. What is non - destructive test?
6. What is destructive test?
7. In which type of test the capillary action principle is used?
8. How pulse velocity is calculated?
9. The pulse velocity in concrete may be influenced by\_\_\_\_\_.
10. Which is the last step in magnetic particle test method?
11. During radiography test, which region absorbs less radiation and transmits more?
12. Which test is used to determine dimensions of any object?
13. What Are the Advantages of Ultrasonic Testing?
14. What Are the Potential Limitations of Ultrasonic Testing?
15. What Is an Ultrasonic Transducer?
16. What Is an Ultrasonic Thickness Gage?
17. How Accurate Is Ultrasonic Thickness Gaging?
18. What Is an Ultrasonic Flaw Detector?
19. What Is Vibration Analysis?
20. What Sort of Materials Can Be Tested?

21. Symptoms for aggressive ACR reaction?
22. Symptoms for aggressive ASR?
23. What should be the minimum water cement ratio?
24. Cement not more than \_\_\_\_\_ months old should be used.
25. Powder epoxy is fusion bonded to bar at about \_\_\_\_\_ 0C temperature.
26. At the construction stage, binding wires \_\_\_\_\_
27. Creep is \_\_\_\_\_ to the strength of concrete.
28. What is elastic strains?
29. Which test is used to determine dimensions of any object?
  - a) Ultrasonic test
  - b) Torsion test
  - c) Eddy current test
  - d) Compression test
30. Identify the type of destructive testing.
  - a) Radiographic test
  - b) Dye penetrant test
  - c) Creep test
  - d) Visual testing
31. Compressive strength of hardened concrete is done by \_\_\_\_\_
32. In the soundness test a specimen of hardened cement paste is \_\_\_\_\_ for a fixed time.
33. Loss on Ignition (L.O.I.) is the loss in weight of cement after being heated to \_\_\_\_\_
34. On cooling below 1250°C, C<sub>3</sub>S decomposes \_\_\_\_\_
35. What is final setting time?
36. The loss in weight should not exceed \_\_\_\_\_ percent when tested with sodium sulphate and \_\_\_\_\_ percent with magnesium sulphate solution.
37. If 60% aggregates doesn't pass through the 2.36mm sieve, then what would be the value of Aggregate impact value?
38. IS code for Specification for ordinary Portland cement, 33 grade?
39. IS code for Specification for coarse and fine aggregates from natural sources for concrete?
40. IS code for Specification for Portland slag cement?
41. IS Code of practice for plain and reinforced concrete.
42. IS 457:1957 is for \_\_\_\_\_
43. IS 1489(Part 1):1991 is for \_\_\_\_\_
44. IS 1489(Part 2):1991 is for \_\_\_\_\_
45. IS 1727:1967 is for \_\_\_\_\_
46. IS 650:1991 is for \_\_\_\_\_
47. IS 1199:1959 is for \_\_\_\_\_
48. What should be the minimum water cement ratio?
49. Powder epoxy is fusion bonded to bar at about \_\_\_\_\_ 0C temperature.
50. At the construction stage, binding wires \_\_\_\_\_