



MARRI LAXMAN REDDY **INSTITUTE OF TECHNOLOGY AND MANAGEMENT**

(AN AUTONOMOUS INSTITUTION)

(Approved by AICTE, New Delhi & Affiliated to JNTUH, Hyderabad)

Accredited by NBA and NAAC with 'A' Grade & Recognized Under Section 2(f) & 12(B) of the UGC act, 1956

DEPARTMENT MECHANICAL ENGINEERING

FUELS AND LUBRICANTS **LAB MANUAL**



SUBJECT NAME	Fuels and Lubricants Lab
SUBJECT CODE	2030373
COURSE-BRANCH	B. Tech - Mechanical Engineering
YEAR-SEMESTER	II - I
ACADEMIC YEAR	2021-2022
REGULATION	MLRS-R20

MARRI LAXAMAN REDDY

INSTITUTE OF TECHNOLOGY AND MANAGEMENT

MISSION AND VISION OF THE INSTITUTE:

Our Vision:

To establish as an ideal academic institutions in the service of the nation the world and the humanity by graduating talented engineers to be ethically strong globally competent by conducting high quality research, developing breakthrough technologies and disseminating and preserving technical knowledge.

Our Mission:

To fulfill the promised vision through the following strategic characteristics and aspirations:

- Contemporary and rigorous educational experiences that develop the engineers and managers;
- An atmosphere that facilitates personal commitment to the educational success of students in an environment that values diversity and community;
- Prudent and accountable resource management;
- Undergraduate programs that integrate global awareness, communication skills and team building across the curriculum;
- Leadership and service to meet society's needs;
- Education and research partnerships with colleges, universities, and industries to graduate education and training that prepares students for interdisciplinary engineering research and advanced problem solving;
- Highly successful alumni who contribute to the profession in the global society.

Vision and Mission statements of the Department of Mechanical Engineering:

Vision Statement:

“The Mechanical Engineering Department strives immense success in the field of education, research and development by nurturing the budding minds of young engineers inventing sets of new designs and new products which may be envisaged as the modalities to bring about a green future for humanity”

Mission Statement:

1. Equipping the students with manifold technical knowledge to make them efficient and independent thinkers and designers in national and international arena.
2. Encouraging students and faculties to be creative and to develop analytical abilities and efficiency in applying theories into practice, to develop and disseminate new knowledge.

3. Pursuing collaborative work in research and development organizations, industrial enterprises, Research and academic institutions of national and international, to introduce new knowledge and methods in engineering teaching and research in order to orient young minds towards industrial development.

PROGRAM EDUCATIONAL OBJECTIVE

PEO 1: Graduates shall have knowledge and skills to succeed as Mechanical engineer's for their career development.

PEO 2: Graduates will explore in research.

PEO 3: Mechanical Graduates shall have the ability to design products with various interdisciplinary skills

PEO 4: Graduates will serve the society with their professional skills

PROGRAM OUTCOMES

- A.** Engineering Knowledge: Apply the knowledge of mathematics, science, engineering fundamentals and an engineering specialization for the solution of complex engineering problems.
- B.** Problem Analysis: Identify, formulate, research, review the available literature and analyze complex engineering problems reaching substantiated conclusions using first principles of mathematics, natural science and engineering sciences.
- C.** Design and development of solutions: Design solutions for complex engineering problems and design system components or processes that meet the specific needs with appropriate considerations for public health safety and cultural, societal and environmental considerations.
- D.** Conduct investigations of complex problems: Use research based knowledge and research methods including design of experiments, analysis and interpretation of data and synthesis of the information to provide valid conclusions.
- E.** Modern tool usage: Create, select and apply appropriate techniques, resources and modern engineering and IT tools including predictions and modeling to complex engineering activities with an understanding of the limitations.
- F.** The Engineer and society: Apply reasoning, informed by the contextual knowledge to assess societal, health, safety, legal and cultural issues and the consequent responsibilities relevant to the professional engineering practices.
- G.** Environment and sustainability: Understand the impact of the professional engineering solutions in society and environmental context and demonstrate the knowledge of and need for sustainable development.
- H.** Ethics: Apply ethical principles and commitment to professional ethics, responsibilities and norms of the engineering practice.
- I.** Individual and team work: Function effectively as an individual and as a member or leader in diverse teams and in multi disciplinary settings.
- J.** Communication: Communicate effectively on complex engineering activities with the engineering community and with the society at large, such as being able to comprehend, write effective reports, design documentation, make effective presentations, give and receive clear instructions.
- K.** Project management and finance: Demonstrate knowledge and understanding of the engineering and management principles and apply these to one's own work, as a member and leader in a team, to manage projects and in multidisciplinary environments.
- L.** Life – long learning: Recognize the need and have the preparation, ability to engage in independent and life – long learning in the broadest context of technological change.

PROGRAMME SPECIFIC OUTCOMES:

PS01: Students acquire necessary technical skills in mechanical engineering that make them employable graduate.

PSO2: An ability to impart technological inputs towards development of society by becoming an entrepreneur.

COURSE OBJECTIVES:

1. To understand the basic principles of fluid mechanics.
2. To identify various types of flows.
3. To understand boundary layer concepts and flow through pipes.
4. To evaluate the performance of hydraulic turbines.
5. To understand the functioning and characteristic curves of pumps.

COURSE OUTCOMES:

- ME 373.1 Illustrate the viscosity of liquid lubricants.
- ME 373.2 Understand the calorific values of solid and gaseous fuels.
- ME 373.3 Analyze the flash and fire points of liquid fuels.
- ME 373.4 Observe the carbon residue for fuels.
- ME 373.5 Compare the depth penetration for different lubricants.
- ME373.6 Gain in depth knowledge of automobile fuels and lubricants.

INSTRUCTIONS TO THE STUDENTS

1. Every student should obtain a copy of the laboratory manual
2. It is important that all students arrive at each session on time.
3. Dress code: Students must come to the laboratory wearing:
 - Trousers.
 - half-sleeve tops.
 - Leather shoes.
 - Half pants, loosely hanging garments and slippers are not allowed.
4. Students should come with thorough preparation for the experiment to be conducted.
5. Students will not be permitted to attend the laboratory unless they bring the practical record fully completed in all respects pertaining to the experiment conducted in the previous class.
6. Experiment should be started only after the staff-in-charge has checked the experimental setup.
7. All the calculations should be made in the observation book. Specimen calculations for one set of readings have to be shown in the practical record.
8. Wherever graphs are to be drawn, A-4 size graphs only should be used and the same should be firmly attached to the practical record.
9. Practical record and observation should be neatly maintained.
10. They should obtain the signature of the staff-in-charge in the observation book after completing each experiment.
11. Theory regarding each experiment should be written in the practical record before procedure in your own words.

LABORATORY SAFETY PRECAUTIONS

1. Laboratory uniform, shoes & safety glasses are compulsory in the lab.
2. Do not touch anything with which you are not completely familiar. Carelessness may not only break the valuable equipment in the lab but may also cause serious injury to you and others in the lab.
3. Please follow instructions precisely as instructed by your supervisor. Do not start the experiment unless your setup is verified & approved by your supervisor.
4. Do not leave the experiments unattended while in progress.
5. Do not crowd around the equipment's & run inside the laboratory.
6. During experiments material may fail and disperse, please wear safety glasses and maintain a safe distance from the experiment.
7. If any part of the equipment fails while being used, report it immediately to your supervisor. Never try to fix the problem yourself because you could further damage the equipment and harm yourself and others in the lab.
8. Keep the work area clear of all materials except those needed for your work and cleanup after your work.

LIST OF EXPERIMENTS

1. Determination of Flash and Fire points of Liquid fuels/Lubricants using: Abels Apparatus.
2. Determination of Flash and Fire points of Liquid fuels/Lubricants using: Pensky Martens
3. Apparatus.
4. Carbon residue test: Liquid fuels.
5. Determination of Viscosity of Liquid lubricants and Fuels using: Saybolt Viscometer.
6. Determination of Viscosity of Liquid lubricants and Fuels using: Redwood Viscometer –I.
7. Determination of Viscosity of Liquid lubricants and Fuels using: Redwood Viscometer – II.
8. Determination of Viscosity of Liquid lubricants and Fuels using: Engler Viscometer.
9. Determination of Calorific value: of Gaseous fuels using: Junkers Gas Calorimeter.
10. Determination of Calorific value: Solid/Liquid/ fuels using: Bomb Calorimeter.
11. Drop point and Penetration Apparatus for Grease.
12. ASTM Distillation Test Apparatus.
13. Cloud and Pour point Apparatus.



MARRI LAXMAN REDDY **INSTITUTE OF TECHNOLOGY AND MANAGEMENT**

(AN AUTONOMOUS INSTITUTION)

(Approved by AICTE, New Delhi & Affiliated to JNTUH, Hyderabad)

Accredited by NBA and NAAC with 'A' Grade & Recognized Under Section 2(f) & 12(B) of the UGC act, 1956

CONTENTS

Sl. No.	EXPERIMENT NAME	PAGE No.
1.	DETERMINATION OF FLASH AND FIRE POINTS OF LIQUID FUELS/LUBRICANTS USING: ABELS APPARATUS	1-5
2.	DETERMINATION OF FLASH AND FIRE POINTS OF LIQUID FUELS/LUBRICANTS USING: PENSKY MARTENS APPARATUS	6-10
3.	CARBON RESIDUE TEST: LIQUID FUELS.	11-15
4.	DETERMINATION OF VISCOSITY OF LIQUID LUBRICANTS AND FUELS USING: SAYBOLT VISCOMETER	16-20
5.	DETERMINATION OF VISCOSITY OF LIQUID LUBRICANTS AND FUELS USING: REDWOOD VISCOMETER - I	21-25
6.	DETERMINATION OF VISCOSITY OF LIQUID LUBRICANTS AND FUELS USING: REDWOOD VISCOMETER - II	26-30
7.	DETERMINATION OF VISCOSITY OF LIQUID LUBRICANTS AND FUELS USING: ENGLER VISCOMETER	31-34
8.	DETERMINATION OF CALORIFIC VALUE: OF GASEOUS FUELS USING: JUNKERS GAS CALORIMETER.	35-39
9.	DETERMINATION OF CALORIFIC VALUE: SOLID/LIQUID/ FUELS USING: BOMB CALORIMETER.	40-46
10.	DROP POINT AND PENETRATION APPARATUS FOR GREASE.	47-50
11.	ASTM DISTILLATION TEST APPARATUS.	51-55
12.	CLOUD AND POUR POINT APPARATUS.	56-60

EXPERIMENT -1

ABEL'S FLASH AND FIRE POINT TEST



AIM:

To determine the flash and fire point of the given sample of oil using Abel's apparatus closed cup methods.

APPARATUS:

Abel's apparatus, Thermometer (0-110°C)

THEORY:

This method determines the closed cup flash and fire points of petroleum products and mixtures to ascertain whether they give off inflammable vapours below a certain temperature.

FLASH POINT:

It is the lowest temperatures of the oil, at which, application of test flame causes the vapour above the sample to ignite with a distinct flash inside the cup.

FIRE POINT:

It is the lowest temperature of the oil, at which, application of test flame causes burning for a period of about five seconds.

DESCRIPTION:

The apparatus consists of a brass cup and cover fitted with shutter mechanism, test flame arrangement, hand stirrer, thermometer socket. The brass cup is heated by water bath (with energy regulator), fitted with a funnel and overflow pipe.

PROCEDURE:

1. Clean the oil cup and fill the up to the mark with the sample oil.
2. Insert the thermometer into the oil cup through the provision to note down the oil temperature.
3. Using the Energy regulator, control the power supply given to the heater and rate of heating
4. The oil is heated slowly when temperature of oil rises; it is checked for the flash point for every one-degree rise in temperature.
5. After determining the flash point, the heating shall be further continued. The temperature at which time of flame application that causes burning for a period at least 5 seconds shall be recorded as the fire point.
6. Repeat the experiment 2 or 3 times with fresh sample of the same oil
7. Take the average value of flash and fire points.

OBSERVATIONS:

Sample oil	Flash Point, ° C	Fire Point, ° C

PRECAUTIONS:

1. As the moisture affects the flash point the cup and its accessories coming in contact with oil should be dried.
2. No oil should remain between the sliding and fixed plates forming the cover of the cup. If present it must be cleaned. Care should be taken to prevent wetting of the cup above the pointer tip.
3. Always a fresh sample of the oil should be used. A second determination on the same used oil shows higher flash point.
4. Thermometer should be inserted carefully through the clamp. The thermometer bulb should never touch the bottom of the oil cup. Thermometer should never be in line with the stirrer plates.
5. Stirrer should be disconnected during the application of the test flame. During the application of the test flame the slide should be open slowly but closed quickly.

RESULT:

The flash point is observed at _____ ° C

The fire point is observed at _____ ° C

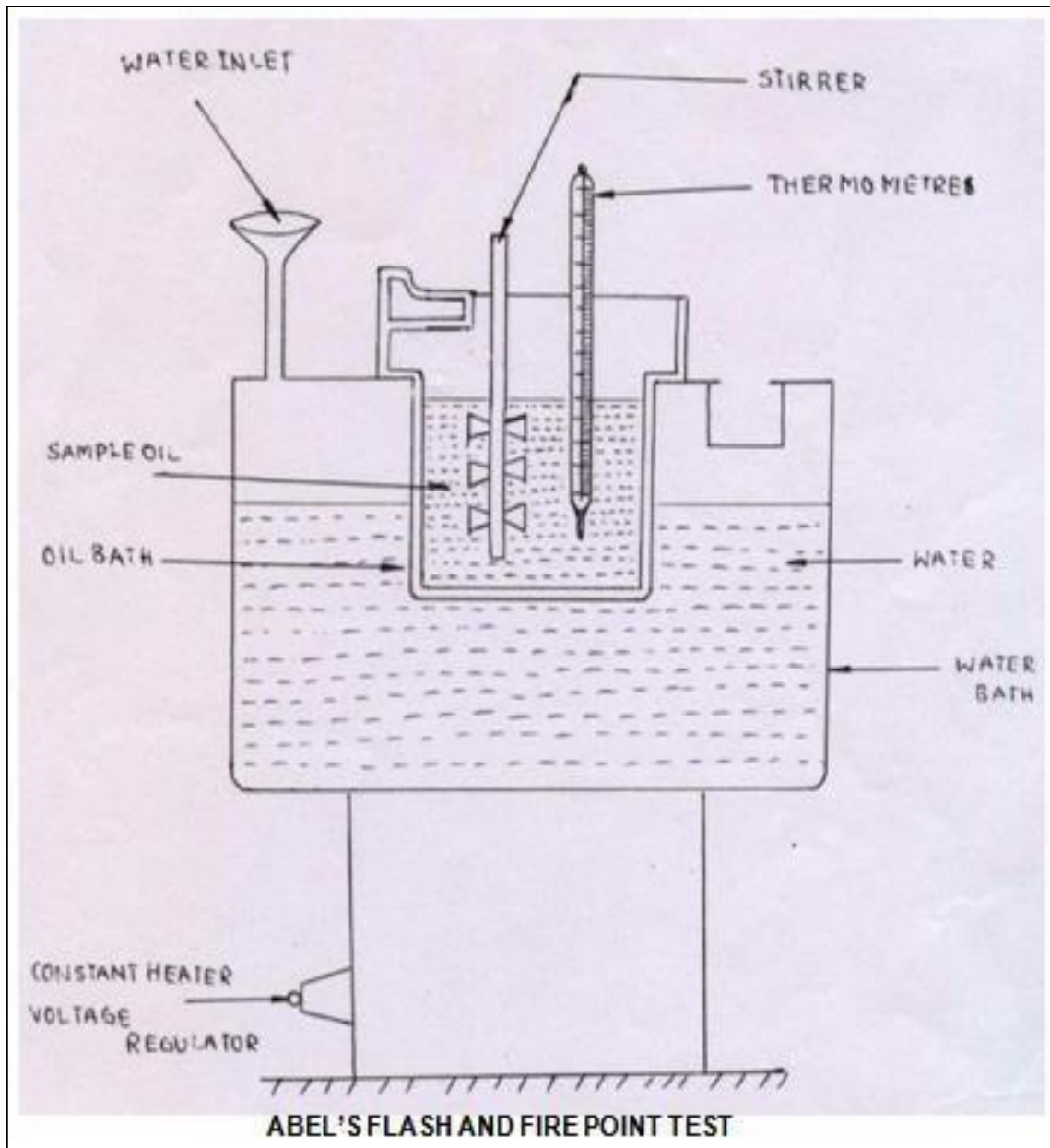

VIVA QUESTIONS:

1. What is meant by flash point?
2. What is Flash point and its importance in applications point of view?
3. What is Fire point and its importance in applications point of view?
4. Constructional difference between Pensky martin & Abel's apparatus, which is the best one?
5. Why stirring is done in fire and flash point measuring apparatus?
6. What is meant by fire point?
7. What is meant by fuel?
8. How do you classify fuels?
9. The lowest temperature at which the oils gives enough vapour.
10. The fire point of an oil is about_____higher than the flash point.
11. The fire point is the lowest temperature at which the vapour of oil burns continuously for atleast___when a small flame is brought near to it.
12. The lubricating oil is volatilises then the formed vapour _____
13. Pensky-Marten's apparatus is used to find out the _____
14. Oil cup in Pensky-marten's apparatus is made with _____
15. The location of the cup in air bath can be known using _____
16. Flame exposure device is connected with _____
17. Transformer oils must have _____
18. The maximum pour-point requirements for refrigerator system are about forlightest grade.
19. For refrigerator system, the oils with the low viscosity, high cloud point and low pour pointare used.
20. What are the factors affecting the flash and fire point?

EXPERIMENT -2

PENSKY MARTEN'S FLASH AND FIRE POINT TEST



AIM:

To determine the flash and fire point of the given sample of oil using Pensky Marten's apparatus by both open and closed cup methods.

APPARATUS:

Pensky Marten's Apparatus, Thermometer (0 – 110⁰C)

THEORY:

This method determines the closed cup and open cup flash and fire points of petroleum products and mixtures to ascertain whether they give off inflammable vapours below a certain temperature.

Flash Point:

It is the lowest temperatures of the oil at which application of test flame causes the vapour above the sample to ignite with a distinct flash inside the cup.

Fire Point:

It is the lowest temperature of the oil, at which, application of test flame causes burning for a period of about five seconds.

DESCRIPTION:

The apparatus consists of a brass cup and cover fitted with shutter mechanism without shutter mechanism (open cup), test flame arrangement, hand stirrer (closed cup), thermometer socket, etc., heated with energy regulator, a thermometer socket made of copper.

PROCEDURE:

1. Clean the oil cup thoroughly and fill the oil cup with the sample oil to be tested up to the mark.
2. Insert the thermometer into the oil cup through a provision, which measures the rise of oil temperature.
3. Using the Energy regulator, control the power supply given to the heater and rate of heating
4. The oil is heated slowly when temperature of oil rises, it is checked for the flash point for every one degree rise in temperature.
5. After determining the flash point, the heating shall be further continued. The temperature at which time of flame application which causes burning for a period at least 5 seconds shall be recorded as the fire point.
6. Repeat the experiment 2 or 3 times with fresh sample of the same oil
7. Take the average value of flash and fire points.

OBSERVATIONS:

Sample oil	Flash Point, ° C	Fire Point, ° C

PRECAUTIONS:

1. As the moisture affects the flash point the cup and its accessories coming in contact with oil should be dried.
2. No oil should remain between the sliding and fixed plates forming the cover of the cup. If present it must be cleaned. Care should be taken to prevent wetting of the cup above the pointer tip.
3. Always a fresh sample of the oil should be used. A second determination on the same used oil shows higher flash point.
4. Thermometer should be inserted carefully through the clamp. The thermometer bulb should never touch the bottom of the oil cup. Thermometer should never be in line with the stirrer plates.
5. Stirrer should be disconnected during the application of the test flame. During the application of the test flame the slide should be open slowly but closed quickly.
6. Flash points of lubricating oils, some crude oils and residues are often determined by the open cup tests. Either PENSKEY MARTIN's or CLEVELAND open-cup is used. The open-cup method is liable to error and gives only approximate values. The open cup flash point is higher than the closed cup value for the same sample.

RESULT:

The flash point is observed at _____ ° C

The fire point is observed at _____ ° C

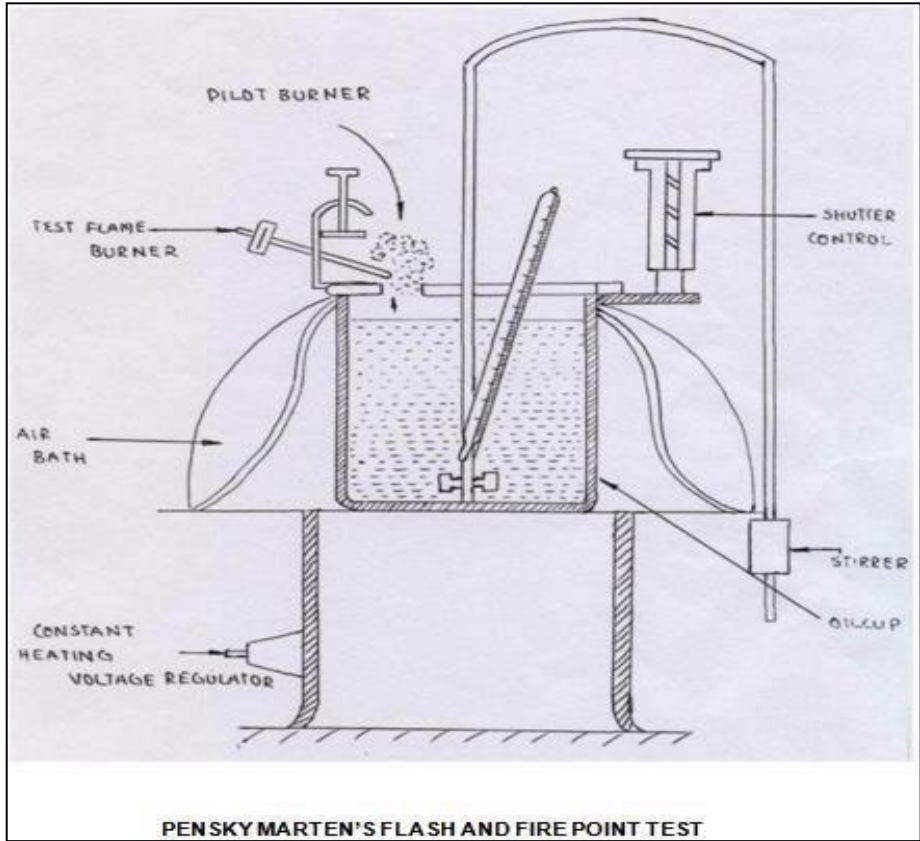

VIVA QUESTIONS:

1. What is meant by flash point?
2. What is Flash point and its importance in applications point of view?
3. What is Fire point and its importance in applications point of view?
4. Constructional difference between Pensky martin & Abel's apparatus, which is the best one?
5. Why stirring is done in fire and flash point measuring apparatus?
6. What is meant by fire point?
7. What is meant by fuel?
8. How do you classify fuels?
9. The lowest temperature at which the oils gives enough vapour.
10. The fire point of an oil is about _____ higher than the flash point.
11. The fire point is the lowest temperature at which the vapour of oil burns continuously for at least _____ when a small flame is brought near to it.
12. The lubricating oil is volatilises then the formed vapour _____
13. Pensky-Marten's apparatus is used to find out the _____
14. Oil cup in Pensky-marten's apparatus is made with _____
15. The location of the cup in air bath can be known using _____
16. Flame exposure device is connected with _____
17. Transformer oils must have _____
18. The maximum pour-point requirements for refrigerator system are about _____ for lightest grade.
19. For refrigerator system, the oils with the low viscosity, high cloud point and low pour point are used.
20. What are the factors affecting the flash and fire point?

EXPERIMENT -3

CARBON RESIDUE **(CONRADSON) TEST**

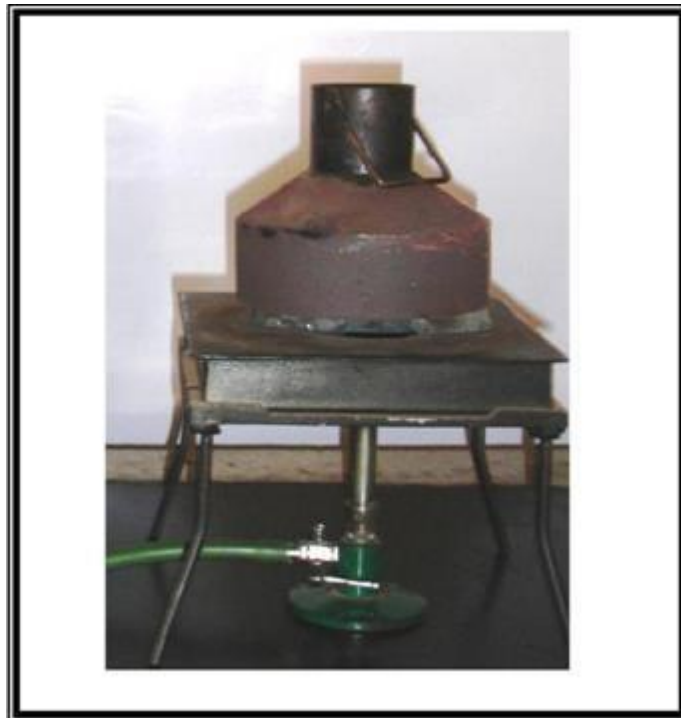

AIM:

To determine the carbon residue of the given sample of lubricating oil / Fuel.

APPARATUS:

Carbon residue (Conradson) apparatus, Analytical balance with Weight box

THEORY:

Most of the lubricant oils are containing high percentage of carbon in combined form and fuels containing less percentage of carbon in combined form. On heating, they decompose depositing a certain amount of carbon. The deposition of such carbon in machine is intolerable, particularly in internal combustion engines and air compressors. A good lubricant should deposit least amount of the carbon in use.

PROCEDURE:

1. The weighed porcelain or silica crucible with approximately 2 grams of sample is placed in the center of skid more crucible.
2. The skid more crucible is provided with lid, having a small tube type opening for the escape of volatile matter.
3. The combination is then placed in a wrought iron crucible covered with chimney shaped iron hood.
4. The wrought iron crucible is heated slowly till flame appears. Slow heating continues for 5 minutes more.
5. Finally, strong heating is done for about 15 minutes till vapors of all volatile matter are burnt completely.
6. Apparatus is then allowed to cool and weight of residue left is determined.
7. The result is expressed as percentage of the original weight of oil taken.

OBSERVATIONS:

1. Weight of the crucible $W_1 =$ _____ gms
2. Weight of the crucible with oil $W_2 =$ _____ gms
3. Weight of crucible with residue $W_3 =$ _____ gms

CALCULATION:

Percentage of carbon residue = [(Weight of residue) / (original weight of sample)] x 100

$$= [(W_3 - W_1) / (W_2 - W_1)] \times 100$$

OBSERVATIONS TABLE:

Sample oil	Weight of residue gms	Percentage of carbon residue %

PRECAUTIONS:

1. No oil should remain between the sliding and fixed plates forming the cover of the cup. If present it must be cleaned. Care should be taken to prevent wetting of the cup above the pointer tip.
2. Always a fresh sample of the oil should be used. A second determination on the same used oil shows higher flash point.
3. Thermometer should be inserted carefully through the clamp. The thermometer bulb should never touch the bottom of the oil cup. Thermometer should never be in line with the stirrer plates.
4. Stirrer should be disconnected during the application of the test flame. During the application of the test flame the slide should be open slowly but closed quickly.

RESULT:

The percentage of carbon present in given sample of lubricating oil is _____%

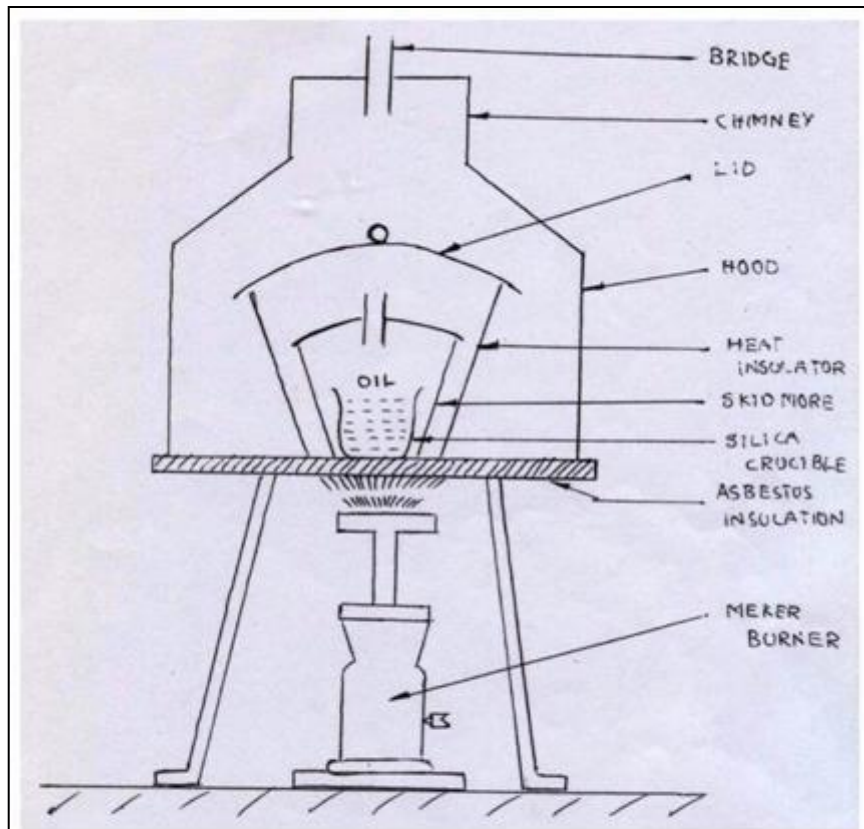

CARBON RESIDUE (CONRADSON) APPARATUS

VIVA QUESTIONS:

1. What is meant by flash point?
2. What is meant by fire point?
3. What is meant by fuel?
4. How do you classify fuels?
5. The lowest temperature at which the oils gives enough vapour.
6. The fire point of an oil is about _____ higher than the flash point.
7. The fire point is the lowest temperature at which the vapour of oil burns continuously for at least _____ when a small flame is brought near to it.
8. The lubricating oil is volatilises then the formed vapour _____
9. Pensky-Marten's apparatus is used to find out the _____
10. Oil cup in Carbon Residue apparatus is made with _____
11. The location of the cup in air bath can be known using _____
12. Flame exposure device is connected with _____
13. Transformer oils must have _____
14. The maximum pour-point requirements for refrigerator system are about _____ for lightest grade.
15. For refrigerator system, the oils with the low viscosity, high cloud point and low pour point are used.
16. What are the factors affecting the flash and fire point?
17. How to improve the flash point of petroleum products?
18. What is the difference between flash point and fire point?
19. Constructional difference between Pensky martin ,Abel's apparatus & Carbon Residue which is the best one?
20. Why stirring is done in fire and flash point measuring apparatus?

EXPERIMENT -4

SAYBOLT VISCOMETER



AIM:

To determine the viscosity in Saybolt seconds of the given sample of oil and to plot the variation of Saybolt seconds, kinematic and dynamic viscosity with temperature.

INSTRUMENTS:

Saybolt Viscometer, Stop Watch, Thermometer (0 – 110⁰C), Measuring Flask (60 c.c)

THEORY:

The viscosity of given oil is determined as the time of flow in Saybolt seconds. The viscosity of a fluid indicates the resistance offered to shear under laminar condition. Dynamic viscosity of a fluid is the tangential force on unit area of either of two parallel planes at unit distance apart when the space between the plates is filled with the fluid and one of the plate's moves relative to the other with unit velocity in its own plane. The unit of dynamic viscosity is dyne-sec/cm². Kinematic viscosity of a fluid is equal to the ratio of the dynamic viscosity and density of the fluid. The unit of kinematic viscosity is cm²/sec.

DESCRIPTION:

Saybolt viscometer consists of a water bath and oil bath, both provided with two thermometers inside them. There is a ball valve, which is located at center of oil bath to flow of oil through the orifice. A heater with regulator is fixed for heating purpose.

PROCEDURE:

1. Clean the oil cup with a suitable solvent thoroughly and dry it using soft tissue paper.
2. Keep the cork in its position so as to keep the orifice closed.
3. The water is taken into the water bath and the oil whose viscosity is to be determined is taken into the oil cup up to the mark.
4. Before switch on the electric supply, at room temperature note down the time taken in Saybolt seconds for a collection of 60 c.c. of oil with a stop watch.
5. Heat the bath and continuously stir it taking care to see that heating of the bath is done in a careful and controlled manner.
6. When the desired temperature is reached, place the cleaned 60 c.c. flask below the orifice in position.
7. Remove the cork valve and simultaneously start a stopwatch. Note the time of collection of oil up to the 60 c.c. Mark.
8. During the collection of oil don't stir the bath.
9. Repeat the process at various temperatures.

OBSERVATIONS:

S. No.	Oil Temperature °C	Time for collecting 50 c.c. of oil (sec)	Kinematic viscosity $V = (A \times t) - (b/t)$ cm ² /sec	Density (ρ) Gm/sec	Absolute Viscosity $\mu = v \times \rho$ dyne - sec/cm ²

Where $A = 0.026 \text{ cm}^2$ $B = 1.8 \text{ cm}^2/\text{sec}^2$

GRAPHS TO BE DRAWN

1. Saybolt seconds vs. temperature
2. Kinematic Viscosity vs. temperature
3. Dynamic Viscosity vs. temperature

MODEL GRAPHS:

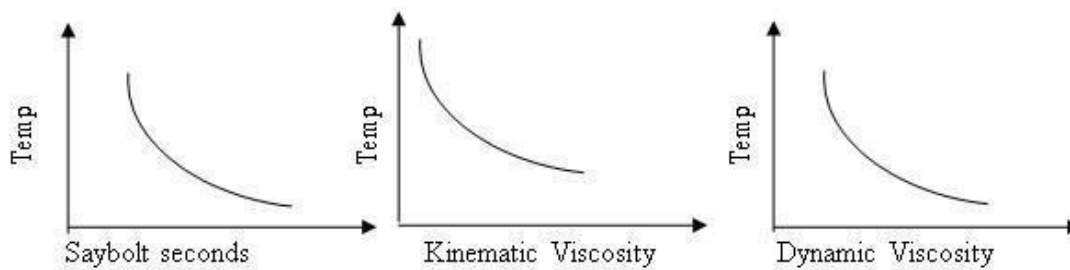

PRECAUTIONS

1. Stir the water continuously so that the temperature of the oil and water are equal.
2. Before collecting the oil at a temperature, check whether the oil is up to the level.
3. Always take the readings at a stable temperature.
4. Ensure proper setting of the cork to avoid leakage.

RESULT:

Variation of Saybolt Seconds, Absolute viscosity and Kinematic viscosity with temperature, were observed and found to be decreasing with temperature

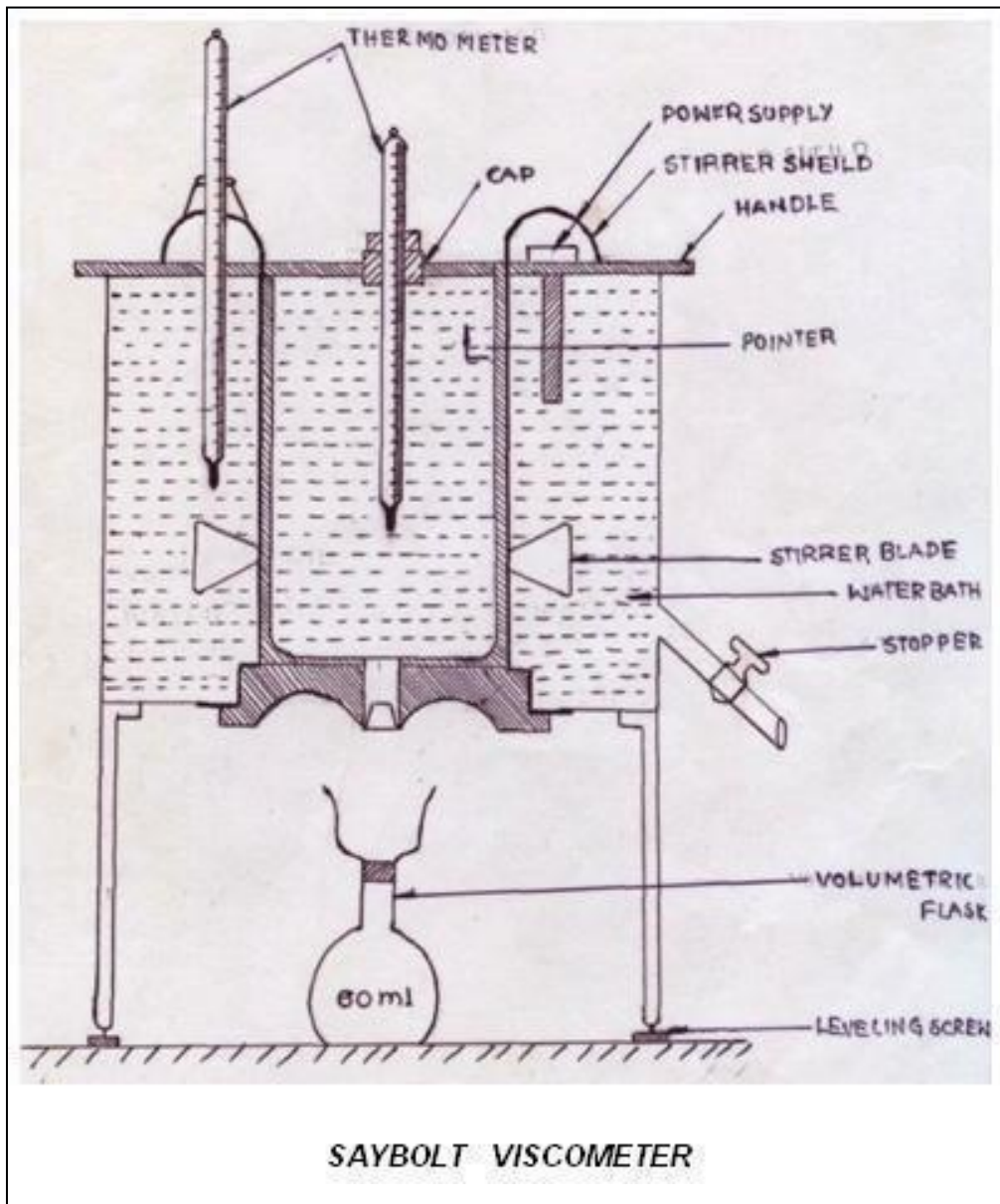

VIVA QUESTIONS

1. What is Viscosity?
2. What are different types of viscosity explain them and write the units?
3. What are factors effecting viscosity?
4. Mention some applications where viscosity is considered?
5. Relation between density and viscosity?
6. Mention different types of oils used in lubricating purposes?
7. How does SAE grade differ in lubricants oils used summer and winter?
8. How the power consumptions varies with viscosity of lubricant in rotation of shaft?
9. Selection of viscometers based on grading or viscosity of oil?
10. Which constructional feature of viscometer varies with the viscosity of oil?
11. Why stirring is done in viscometer and fire and flash point measuring apparatus?
12. Properties of good lubricant?
13. How does viscosity effects lubricants?
14. What is the temperature range for Redwood – I viscometer?
15. What is the difference between Redwood – I viscometer and Redwood – II viscometer?
16. What is the difference between 2 – Stroke and 4 – Stroke engine oil?
17. What is difference between Redwood, Saybolt and Engler's viscometer?
18. What is the difference between Kinetic Viscosity and Dynamic Viscosity?
19. What is meant by Lubrication?
20. What are the properties of Lubricants?

EXPERIMENT -5

REDWOOD VISCOMETER – I



AIM:

To determine the viscosity in Redwood seconds of the given sample of oil and to plot the variation of Redwood seconds, kinematic and dynamic viscosity with temperature.

APPARATUS:

Redwood Viscometer- I, Stop Watch, Thermometer (0-110⁰), Measuring Flask (50 cc)

THEORY:

The viscosity of given oil is determined as the time of flow in Redwood seconds. The viscosity of a fluid indicates the resistance offered to shear under laminar condition. Dynamic viscosity of a fluid is the tangential force on unit area of either of two parallel planes at unit distance apart when the space between the plates is filled with the fluid and one of the plate's moves relative to the other with unit velocity in its own plane.

The unit of dynamic viscosity is dyne-sec/cm². Kinematic viscosity of a fluid is equal to the ratio of the dynamic viscosity and density of the fluid. The unit of kinematic viscosity is cm² /sec.

DESCRIPTION:

Redwood viscometer-I consists of a water bath and oil bath, both provided with two thermometers inside them. There is a ball valve, which is located at center of oil bath to flow of oil through the orifice. A heater with regulator is fixed for heating purpose.

PROCEDURE:

1. Clean the oil cup with a suitable solvent thoroughly and dry it using soft tissue paper.
2. Keep the ball valve in its position so as to keep the orifice closed
3. The water is taken into the water bath and the oil whose viscosity is to be determined is taken into the oil cup up to the mark.
4. Note down the time taken in Redwood seconds for a collection of 50 cc. of oil with a stopwatch at the room temperature without supply of electric supply.
5. Heat the bath and continuously stir it taking care to see that heating of the bath is done in a careful and controlled manner.
6. When the desired temperature is reached, place the cleaned 50 c.c. Flask below the orifice in position.
7. Remove the ball valve and simultaneously start a stopwatch. Note the time of collection of oil up to the 50 c.c. Mark.
8. During the collection of oil don't stir the bath. Repeat the process at various temperatures.

OBSERVATIONS

S. No.	Oil Temperature $^{\circ}\text{C}$	Time for collecting 50 c.c. of oil (sec)	Kinematic viscosity $V = (A \times t) - (b/t)$ cm^2/sec	Density (ρ) Gm/sec	Absolute Viscosity $\mu = \nu \times \rho$ dyne - sec/cm ²

Where $A = 0.026 \text{ cm}^2$ $B = 1.72 \text{ cm}^2/\text{sec}^2$

GRAPHS TO BE DRAWN

1. Redwood seconds Vs. temperature
2. Kinematic Viscosity Vs. temperature
3. Absolute Viscosity Vs. Temperature

MODEL GRAPHS

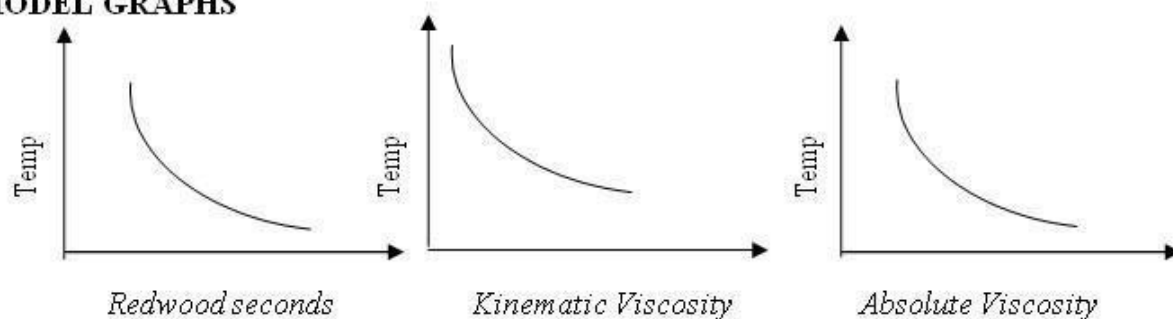

PRECAUTIONS

1. Stir the water continuously so that the temperature of the oil and water are equal.
2. Before collecting the oil at a temperature, check whether the oil is up to the Indicator in the oil cup.
3. Always take the readings at a stable temperature
4. Ensure proper setting of the ball valve to avoid leakage

RESULT

Variation of Redwood seconds, absolute viscosity and Kinematic viscosity with temperature, were observed and found to be decreasing with temperature

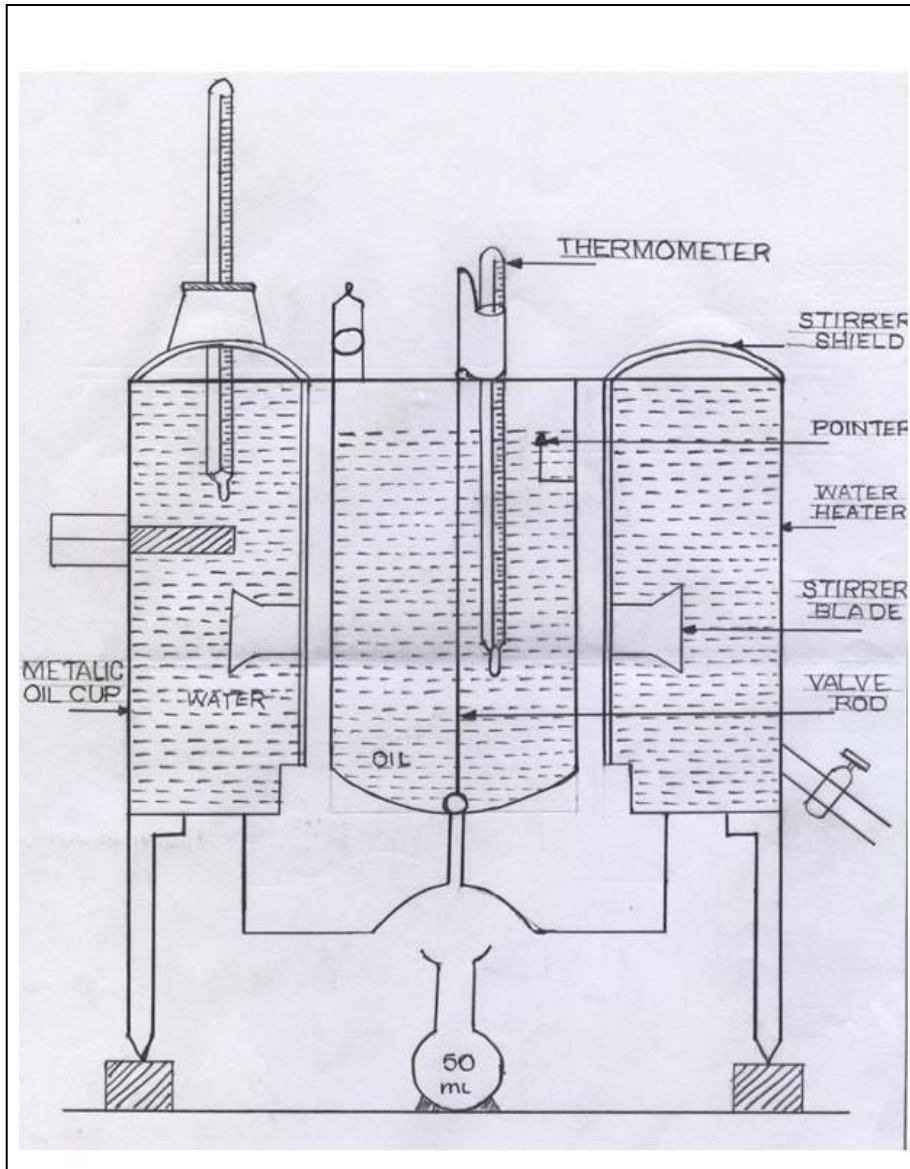

VIVA QUESTIONS

1. What is the difference between Redwood – I viscometer and Redwood – II viscometer?
2. What is the difference between 2 – Stroke and 4 – Stroke engine oil?
3. What is difference between Redwood, Saybolt and Engler’s viscometer?
4. What is the difference between Kinetic Viscosity and Dynamic Viscosity?
5. What is meant by Lubrication?
6. What are the properties of Lubricants?
7. What is Viscosity?
8. What are different types of viscosity explain them and write the units?
9. What are factors effecting viscosity?
10. Mention some applications where viscosity is considered?
11. Relation between density and viscosity?
12. Mention different types of oils used in lubricating purposes?
13. How does SAE grade differ in lubricants oils used summer and winter?
14. How the power consumptions varies with viscosity of lubricant in rotation of shaft?
15. Selection of viscometers based on grading or viscosity of oil?
16. Which constructional feature of viscometer varies with the viscosity of oil?
17. Why stirring is done in fire and flash point measuring apparatus?
18. Explain premixed combustion
19. Explain diffusive combustion
20. Give briefly frictional losses in engine

EXPERIMENT -6

REDWOOD VISCOMETER – II



AIM:

To determine the viscosity in redwood second of the given samples of oil and to plot the variation of Redwood seconds, kinematic and dynamic viscosity with temperature.

INSTRUMENTS:

Redwood Viscometer-II ,Stop Watch, Thermometer (0-110⁰),Measuring Flask (50 cc)

THEORY:

The viscosity of given oil is determined as the time of flow in redwood seconds. The viscosity of a fluid indicates the resistance offered to shear under laminar condition. Dynamic viscosity of a fluid is the tangential force on unit area of either of two parallel planes at unit distance apart when the space between the plates is filled with the fluid and one of the plate's moves relative to the other with unit velocity in its own plane.

The unit of dynamic viscosity is dyne- sec/cm². Kinematic viscosity of a fluid is equal to the ratio of the dynamic viscosity and density of the fluid. The unit of kinematic viscosity is cm²/sec.

DESCRIPTION:

Redwood viscometer-II consists of a water bath and oil bath, both provided with two thermometers inside them. There is a ball valve, which is located at center of oil bath to flow of oil through the orifice. A heater with regulator is fixed for heating purpose.

PROCEDURE:

1. Clean the oil cup with a suitable solvent thoroughly and dry it using soft tissue paper.
2. Keep the ball valve in its position so as to keep the orifice closed.
3. The water is taken into the water bath and the oil whose viscosity is to be determined is taken into the oil cup up to the mark.
4. Before switch on the electric supply, at room temperature note down the time taken in Redwood seconds for a collection of 50 c.c. of oil with a stop watch.
5. Heat the bath and continuously stir it taking care to see that heating of the bath is done in a careful and controlled manner.
6. When the desired temperature is reached, place the cleaned 50 c.c. flask below the orifice in position.
7. Remove the ball valve and simultaneously start a stop watch.
8. Note the time of collection of oil up to the 50 c.c. Mark.
9. During the collection of oil don't stir the bath
10. Repeat the process at various temperatures

OBSERVATIONS:

S. No.	Oil Temperature °C	Time for collecting 50 c.c. of oil (sec)	Kinematic viscosity $V = (A \times t) - (b/t)$ cm ² /sec	Density (ρ) Gm/sec	Absolute Viscosity $\mu = \nu \times \rho$ dyne - sec/cm ²

Where $A = 0.026 \text{ cm}^2$ $B = 1.8 \text{ cm}^2/\text{sec}^2$

GRAPHS TO BE DRAWN

1. Redwood seconds vs. temperature
2. Kinematic Viscosity vs. temperature
3. Absolute Viscosity vs. temperature

MODEL GRAPHS

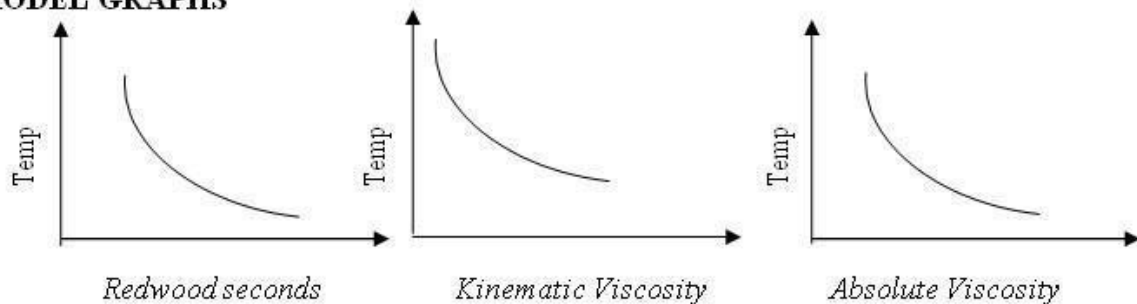

PRECAUTIONS:

1. Stir the water continuously so that the temperature of the oil and water are equal.
2. Before collecting the oil at a temperature, check whether the oil is up to the Indicator in the oil cup.
3. Always take the readings at a stable temperature
4. Ensure proper setting of the ball valve to avoid leakage

RESULT:

Variation of Redwood seconds-II, absolute viscosity and Kinematic viscosity with temperature, were observed and found to be decreasing with temperature

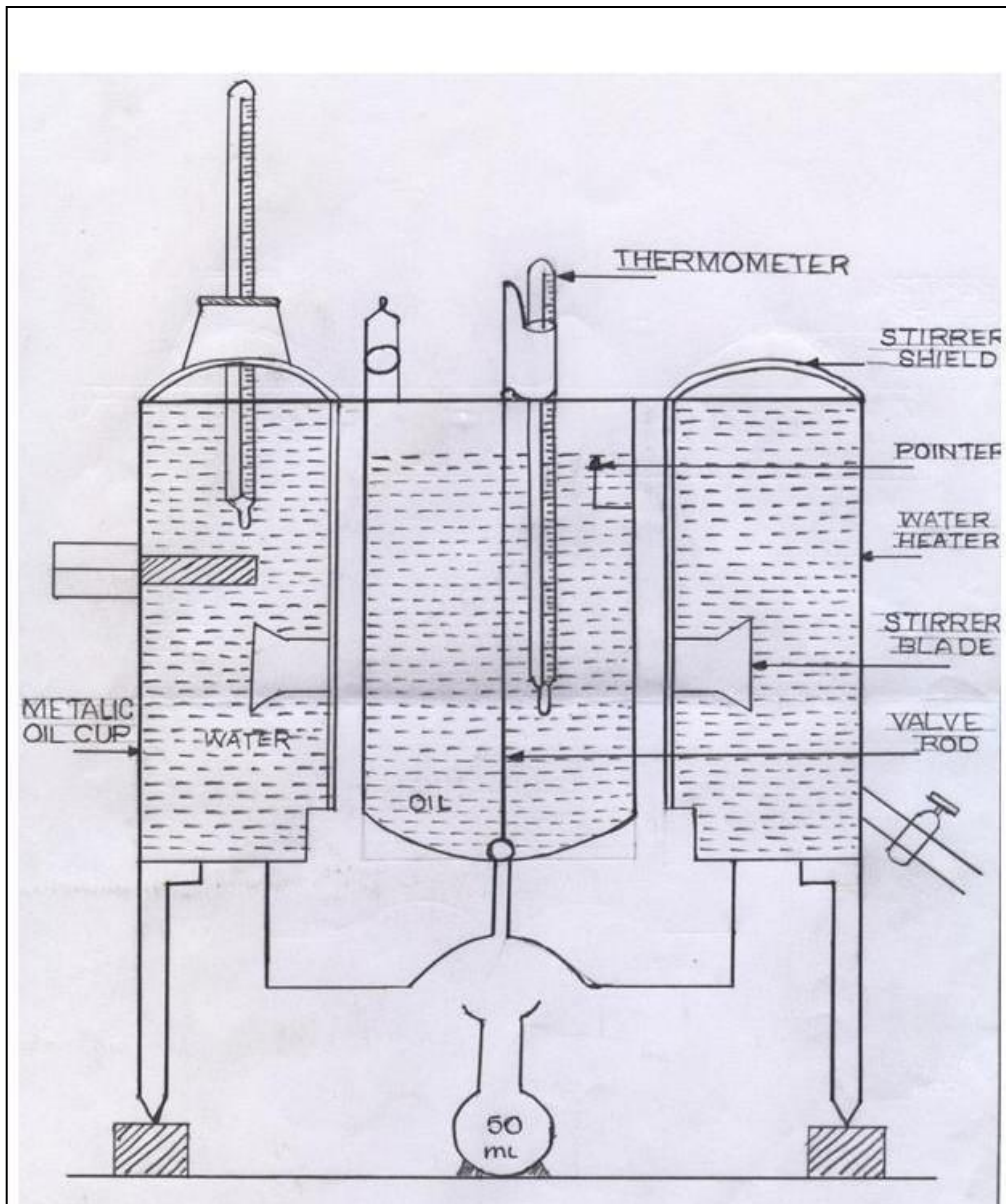

VIVA QUESTIONS

1. Mention different types of oils used in lubricating purposes?
2. How does SAE grade differ in lubricants oils used summer and winter?
3. How the power consumptions varies with viscosity of lubricant in rotation of shaft?
4. Selection of viscometers based on grading or viscosity of oil?
5. Which constructional feature of viscometer varies with the viscosity of oil?
6. Why stirring is done in viscometer and fire and flash point measuring apparatus?
7. Properties of good lubricant?
8. What is Viscosity?
9. What are different types of viscosity explain them and write the units?
10. What are factors effecting viscosity?
11. Mention some applications where viscosity is considered?
12. Relation between density and viscosity?
13. How does viscosity effects lubricants?
14. What is the temperature range for Redwood – II viscometer?
15. What is the difference between Redwood – I viscometer and Redwood – II viscometer?
16. Differentiate between wet sump and dry sump lubrication
17. Give four desired properties of lubrication
18. Explain the petroleum refining process in detail
19. Give four required properties of SI engine fuels and explain in detail
20. Give four required properties of CI engine fuels and explain in detail

EXPERIMENT -7

ENGLER'S VISCOMETER



AIM:

To determine the viscosity in Engler's seconds of the given samples of oil and to plot the variation of Engler's seconds, kinematic and dynamic viscosity with temperature.

APPARATUS:

Engler's viscometer, Stopwatch, Thermometer (0-100⁰C), Measuring flask (200 c.c.)

THEORY:

The viscosity of given oil is determined as the time of flow in Engler's seconds. The viscosity of a fluid indicates the resistance offered to shear under laminar condition. Dynamic viscosity of a fluid is the tangential force on unit area of either of two parallel planes at unit distance apart when the space between the plates is filled with the fluid and one of the plate's moves relative to the other with unit velocity in its own plane. The unit of dynamic viscosity is dyne-sec/cm². Kinematic viscosity of a fluid is equal to the ratio of the dynamic viscosity and density of the fluid. The unit of kinematic viscosity is Cm²/sec.

DESCRIPTION:

Engler's viscometer consists of a water bath and oil bath, both provided with two thermometers inside them. There is an ebonite valve stick, which is located at center of oil bath to flow of oil through the orifice. A heater with regulator is fixed for heating purpose.

PROCEDURE:

1. Clean the oil cup with a suitable solvent thoroughly and dry it using soft tissue paper.
2. Keep the ebonite valve stick in its position so as to keep the orifice closed
3. The water is taken into the water bath and the oil whose viscosity is to be determined is taken into the oil cup up to the mark.
4. Before switch on the electric supply, at room temperature note down the time taken in Engler's seconds for a collection of 200cc. of oil with a stopwatch.
5. Heat the bath and continuously stir it taking care to see that heating of the bath is done in a careful and controlled manner.
6. When the desired temperature is reached, place the cleaned 200 c.c. Flask below the orifice in position.
7. Remove the ebonite valve stick and simultaneously start a stopwatch. Note the time of collection of oil up to the 200 c.c. Mark. During the collection of oil don't stir the bath.
8. Repeat the process at various temperatures.

OBSERVATIONS:

S. No.	Oil Temperature °C	Time for collecting 50 c.c. of oil (sec)	Kinematic viscosity $V = (A \times t) - (b/t)$ cm ² /sec	Density (ρ) Gm/sec	Absolute Viscosity $\mu = \nu \times \rho$ dyne - sec/cm ²

Where $A = 0.0026 \text{ cm}^2$ $B = 1.8 \text{ cm}^2/\text{sec}^2$

GRAPHS TO BE DRAWN:

1. Engler's seconds vs. temperature
2. Kinematic Viscosity vs. temperature
3. Absolute Viscosity vs. temperature

Model graphs:

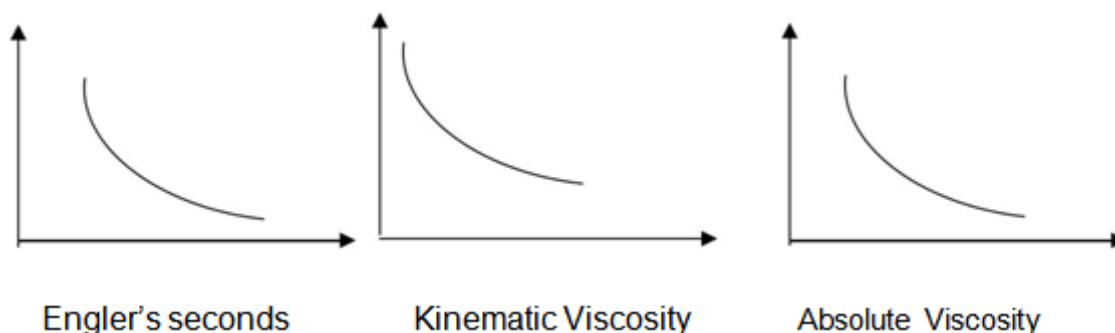

PRECAUTIONS:

1. Stir the water continuously so that the temperature of the oil and water are equal.
2. Before collecting the oil at a temperature, check whether the oil is up to the Indicator in the oil cup.
3. Always take the readings at a stable temperature
4. Ensure proper setting of the Ebonite stick to avoid leakage

RESULTS:

Variation of Engler's seconds, Absolute viscosity and Kinematic viscosity with temperature, were observed and found to be decreasing with temperature

VIVA QUESTIONS

1. Relation between density and viscosity?
2. Mention different types of oils used in lubricating purposes?
3. How does SAE grade differ in lubricants oils used summer and winter?
4. How the power consumptions varies with viscosity of lubricant in rotation of shaft?
5. Selection of viscometers based on grading or viscosity of oil?
6. Which constructional feature of viscometer varies with the viscosity of oil?
7. Why stirring is done in viscometer and fire and flash point measuring apparatus?
8. Properties of good lubricant?
9. How does viscosity effects lubricants?
10. What is the temperature range for Engler viscometer?
11. What is the difference between Redwood viscometer and Engler viscometer?
12. What is Viscosity?
13. What are different types of viscosity explain them and write the units?
14. What are factors effecting viscosity?
15. Mention some applications where viscosity is considered?
16. How SI and CI engine fuels are rated
17. Briefly explain the stages of combustion in SI engines elaborating the flame front propagation
18. Explain the effect of various engine variables on SI engine knock
19. Explain the use of alcohols in SI engines
20. Explain in detail about friction

EXPERIMENT -8

JUNKER'S GAS CALORIMETER



AIM:

To find the calorific value of given gaseous fuel.

APPARATUS:

- i) Calorimeter
 - a) Main calorimeter body

- b) Three thermometers
- ii) Gas flow meter
 - a) Main gas flow meter body
 - b) Inlet / outlet nozzles
 - c) Union nut with washer for thermometers
- iii) Pressure governor
 - a) Pressure governor body
 - b) Balancing beam arrangement
 - c) Counter balance tube
 - d) Inlet and outlet union nuts with washers and
- iv) Jars 2000 ml & 50 ml

PROCEDURE:

1. Pour water into the governor till water starts overflowing through the overflow passage.
2. Replace and tighten the over flow nut.
3. Insert three thermometers provided with calorimeter into the rubber corks.
4. Insert rubber corks with thermometers into their places in calorimeter.
5. Insert burner into its support rod in the bottom of the calorimeter and turn the knurled knob so that the burner is fixed tightly. The burner must go into the center of the calorimeter body.
6. Connect the calorimeter, the flow meter and the pressure governor as shown in figure using rubber tubing provided. Do not connect gas supply line. Take care to see that the water regulator of calorimeter is in OFF position.
7. Turn water regulator knob on calorimeter to ON position. Allow water to flow through the calorimeter from overhead tank/ tap. Allow water to flow for 3 to 4 min into laboratory sink, through the calorimeter.
8. Ensure that outlet tap of governor is closed. Connect gas supply line to governor inlet. Remove burner from calorimeter then open governor outlet tap. Allow gas to pass through the burner.
9. Light up the burner by holding a lighted match stick near the mesh at the top.
10. Adjust the air regulator sleeve at the bottom of the burner to get a blue, non-luminous flame. Fix the lighted burner back into position.
11. Adjust water regulator on calorimeter to get a temperature difference of $12^{\circ} C$ to $15^{\circ} C$ between the inlet water & outlet water as indicated by the respective thermometers at the top of the calorimeter.
12. Allow 20 to 30 min for outlet water temperature to become steady.
13. Measure the water flow rate with the help of measuring jar. Simultaneously, note the flow meter reading.
14. Note down the inlet & outlet water temperatures.
15. Repeat the test with same volume of gas 3 or 4 times and take average temperatures of inlet and outlet water.

CALCULATIONS:

The formula to be used to calculate the calorific value to the test gas is as follows

Where

C.V = calorific value of gas in

V_G = volume of gas in liters consume during test period

V_w = volume of water in liters passed during test period

T_2 = outlet water temperature in $^{\circ}C$

T_1 = inlet water temperature in $^{\circ}C$

OBSERVATIONS:

Trial number	Volume of water collected during the test period V_W m ³ .	Volume of gas burnt during the test period. V_G m ³	Correction factor KN	Equivalent volume of gas burnt at NTP V_{NTP}	Water outlet temperature T_2 oC	Water inlet temperature T_1 oC	Gross Calorific value of the gas C.V. KJ / m ³

PRECAUTIONS:

1. Test reading are to be taken only after steady condition are reached
2. Formation of steam should not be allowed. If there is formation of steam, then increase the flow of water or reduce the gas flow rate
3. Water flow rate should be steady.
4. The inner float of the pressure governor should not be removed since the outlet pressure may vary when refitted

RESULT:

The calorific value gaseous fuel is _____ Kcal/m³

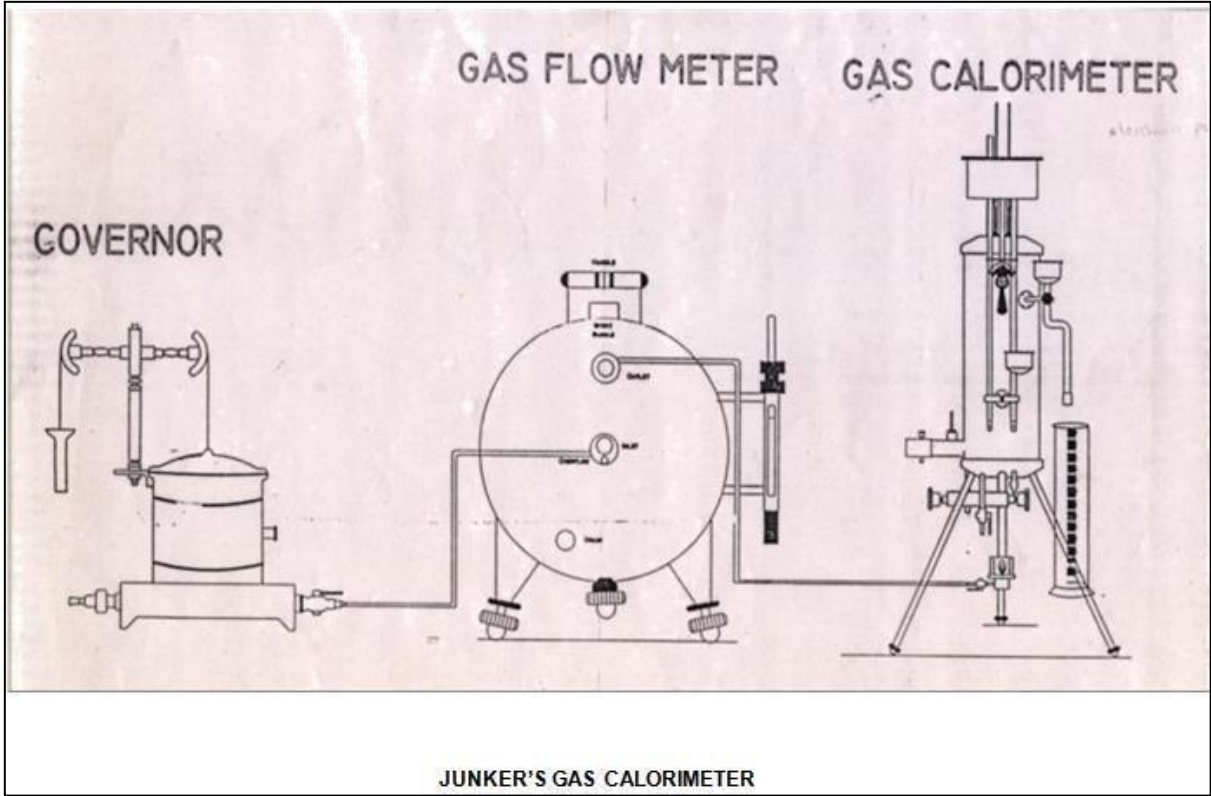

VIVA QUESTIONS

1. Define Calorific value?
2. Define HCV & LCV?
3. Bomb Calorimeter is used to find the calorific values of which fuels?
4. Junker's calorimeter is used to find the calorific value which fuels?
5. Units of Calorific value?
6. What are the advantages, disadvantages of solid, liquid & gaseous fuels?
7. What are the properties required for a good fuel?
8. Relation between Calorie and Joule?
9. Why stirring is done in viscometer and fire and flash point measuring apparatus?
10. Properties of good lubricant?
11. How does viscosity effects lubricants?
12. Units of Calorific value
13. What is the difference between Kinetic Viscosity and Dynamic Viscosity?
14. What is meant by Lubrication?
15. What are the properties of Lubricants?
16. How to improve the flash point of petroleum products?
17. What is the difference between flash point and fire point?
18. Constructional difference between Pensky martin & Abel's apparatus, which is the best one?
19. Why stirring is done in fire and flash point measuring apparatus?
20. How to improve the flash point of petroleum products?

EXPERIMENT -9

BOMB CALORIMETER



AIM:

To determine the water equivalent of the calorimeter using the given sample of solid or liquid fuel of known calorific value (or) To determine the calorific value of the given solid or liquid fuel if the water equivalent of the calorimeter known.

APPARATUS:

Bomb, water jacket, stirrer, calorimeter vessel, combined lid, sensitive thermometer, analytical balance with weight box, oxygen cylinder with pressure gauge, fuse wire, cotton thread, firing unit, regulating valve and crucible hand pellet press

PRINCIPLE OF OPERATION:

A Bomb Calorimeter will measure the amount of heat generated when matter is burnt in a sealed chamber (Bomb) in an atmosphere of pure oxygen gas. A known amount of the sample of fuel is burnt in the sealed bomb, the air in the bomb being replaced by pure oxygen under pressure. The sample is ignited electrically. As the sample burns heat is produced and rises in the temperature. Since the amount of heat produced by burning the sample must be equal to the amount of heat absorbed by the calorimeter assembly, and rise in temperature enables the determination of heat of the combustion of the sample.

If W = Water equivalent of the calorimeter assembly in calories per degree centigrade.

T = Rise in temperature (registered by a sensitive thermometer) in degrees centigrade.

H = Heat of combustion of material in calories per gram.

M = Mass of sample burnt in grams.

Then $W \times T \times H \times M$

If the water equivalent of the calorimeter is to be determined, a substance like Benzoic acid has a stable calorific value can be burnt in the bomb. Assuming the calorific value of Benzoic acid and water equivalent can be determined.

CALORIFIC VALUE:

Gross or higher calorific value: The total amount of heat produced when one unit mass of fuel has been burnt completely and the products of combustion have been cooled to room temperature.

Net or Lower Calorific Value: The net heat produced when unit mass of fuel is burnt completely and the products are permitted to escape.

$LCV = HCV - \text{Latent heat of water vapour formed}$

DESCRIPTION:

Bomb

The bomb consists of three parts i.e. bomb body, lid and the cap. Bomb Body and the lid are made of corrosion resistant stainless steel containing Chromium, Nickel and Molybdenum. The bomb body is cylindrical vessel having a capacity of 300 ml. The walls are strong enough to withstand the normal operating pressure (30atm) to extreme high pressures (300 atm.). During burning at high pressure the nitrogen and sulphur contents are oxidized to nitric acid and sulphuric acid respectively. The corrosion resistant nature of the bomb material protects it from corrosive vapors. The bomb has lid, which is provided with two terminals. The metallic rods pass through the terminals one of which are provided with a ring for placing the crucible with a small hook and the other with a groove. Each rod is also provided with a ring to press the fuse wire attached to it. The upper side of the lid also provided with a small hook rod lifting and with a Schrader valve for filling oxygen in the bomb

Water Jacket

The water jacket is made of copper and is highly chromium plated on the inside and outside to minimize radiation losses. The jacket is filled with water.

Stirrer Unit

A stirrer is provided which is driven directly by an electric motor. The stirrer is immersed in the water. The water is continuously stirred during the experiment for uniform heat distribution.

Combined Lid

This is made of Borolite sheet and is provided with a hole for to keep the stirrer unit in fixed position and hole to insert the temperature sensor. It has also another hole to take out the connecting wires from the terminals on the bomb lid to firing unit.

Hand Pellet Press

It is used for pressing the powder into a pellet.

Crucible

It is made of stainless steel. The fuel to be burnt is weighed in this crucible.

Ignition Wire:

It is recommended that platinum wire used but an alternative nichrome wire is also being offered.

Firing Unit:

It consists of the firing key, provision to give power to the stirrer motor, a switch for operating the stirrer motor, two indicating lamps. When the circuit is completed the indicating lamp glows. After the firing key is closed on, the fuse wire burns, the indicating lamp stops glowing indicating the burning of the fuse wire.

PROCEDURE:

1. About 0.5 to 1gram of finely ground benzoic acid (Preferably compressed into a pellet) is accurately weighed and taken into crucible.
2. Place the bomb lid on the stand provided and stretch pieces of fuse wire across the electrodes (metal rods) provided in the lid tie about 5cm of sewing cotton round the wire.
3. Place the crucible in position and arrange the loose end of the cotton thread to contact the Benzoic acid pellet in the crucible.
4. About 10ml of distilled water are introduced into the bomb to absorb vapors of sulphuric acid and nitric acids formed during the combustion and lid of the bomb is screwed.
5. Charge the bomb slowly with oxygen from the oxygen cylinder to a pressure of 25 atm. close the valve and detach the bomb from the oxygen supply.
6. Fill the calorimeter vessel with sufficient water to submerge the cap of the bomb to a depth of at least 2mm leaving the terminals projecting lower the bomb carefully in the calorimeter vessel and after ascertaining that it is gas tight, connect the terminals to the ignition circuit.
7. Adjust the stirrer and place the temperature sensor and cover in position.
8. Start the stirring mechanism, which must be kept in continuous operation during the experiment after stirring for 5 minutes note the temperature reading of the calorimeter.
9. Close the circuit momentarily to fire the charge and continue the observations of the temperature at an interval of one minute till the rate of change of temperature becomes constant.
10. Afterwards stop the stirrer and remove the power supply to the firing unit. Remove the bomb from the calorimeter and relax the pressure by opening the valve.
11. Verify that the combustion is complete and wash out the contents of the bomb clean and dry.
12. Calculate the calorific value of the fuel or water equivalent of the calorimeter.

OBSERVATIONS:

Weight of the empty crucible $W_1 = \text{gm}$
Weight of the empty crucible + Benzoic acid pellet $W_2 = \text{gm}$
Weight of the benzoic acid pellet $(W_2 - W_1) = \text{gm}$
Weight of water taken in the calorimeter $W_3 = \text{gm}$
Temperature of the water just before firing $t_1 = ^\circ\text{C}$
Temperature of the water just after firing $t_2 = ^\circ\text{C}$

CALCULATIONS:

Heat produced by burning of benzoic acid + Heat produced by burning of fuse wire and cotton wire etc = Heat absorbed by calorimeter.

$$(W_2 - W_1) \times C_V = (W_3 - W_e)(t_2 - t_1)$$

OBSERVATION TABLE:

TI	1	2	3	4	5	5.5	6	6.5	7	7.5	8	8.5	9	9.5	10	10.5	11	11.5	12	12.5	
ME																					
(min)																					
TE																					
MP																					
OC																					

PRECAUTIONS:

1. Sample should not exceed 1 gms.
2. Don't charge with more oxygen than is necessary.
3. Don't fire the bomb if gas bubbles are leaking from the bomb when it is submerged in water

RESULT

Water equivalent of calorimeter $W_e =$
Calorific value of sample $C_v =$

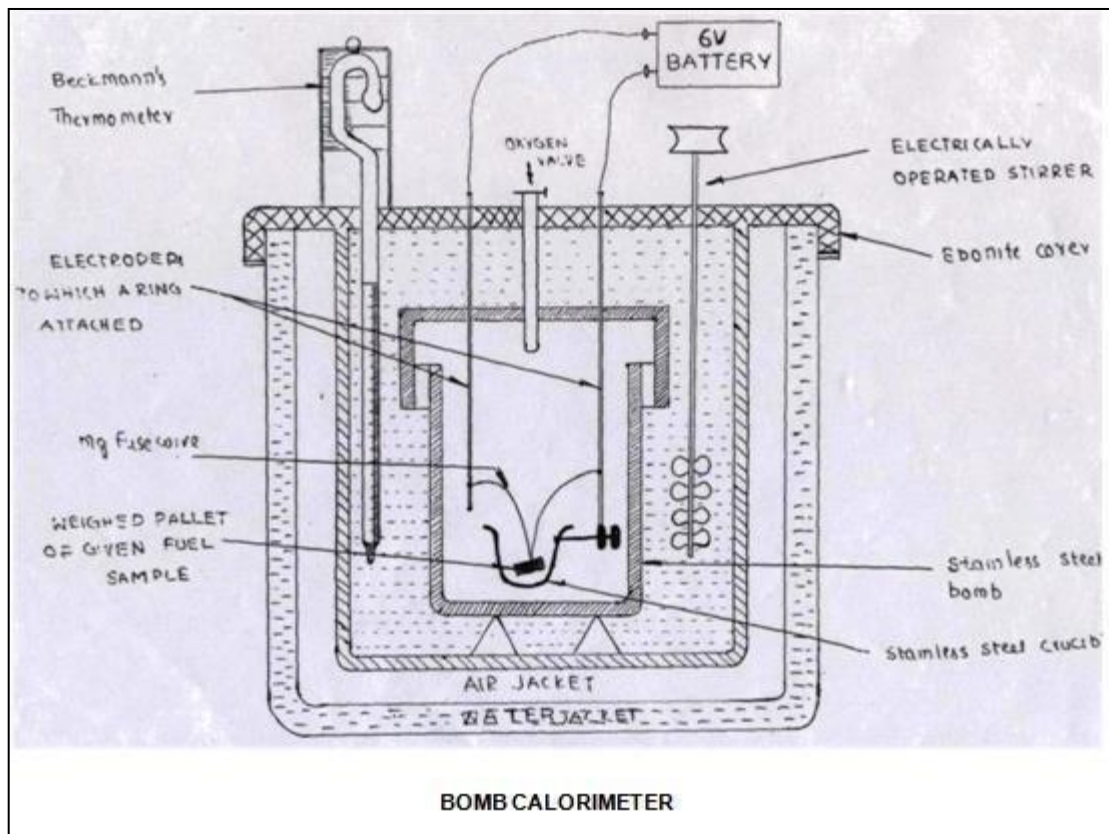

VIVA QUESTIONS

1. Why stirring is done in viscometer and fire and flash point measuring apparatus?
2. Properties of good lubricant?
3. How viscosity does effects lubricants?
4. Units of Calorific value
5. What is the difference between Kinetic Viscosity and Dynamic Viscosity?
6. What is meant by Lubrication?
7. What are the properties of Lubricants?
8. Define Calorific value?
9. Define HCV & LCV?
10. Bomb Calorimeter is used to find the calorific values of which fuels?
11. Junker's calorimeter is used to find the calorific value which fuels?
12. Units of Calorific value?
13. What are the advantages, disadvantages of solid, liquid & gaseous fuels?
14. What are the properties required for a good fuel?
15. Relation between Calorie and Joule?
16. Explain six classes of mechanical friction and various factors affecting them
17. Explain in detail about hydrostatic and hydro dynamic lubrication
18. Explain in detail about wet sump and dry sump lubrication
19. What are the various desired properties of a lubricant and explain how to additives help to achieve the desired properties
20. Explain premixed combustion in detail

EXPERIMENT -10

PENETRATION TEST



AIM:

To determine the penetration of the given sample with the help of Penetrometer

APPARATUS:

Penetrometer, Needle, Sample Cup Weights

DESCRIPTION:

Consistency or yield value is expressed in terms of penetration, which is defined as “the distance in tenth of millimeter that a standard cone or needle penetrates vertically into the sample, under the standard conditions of load, temperature and time. Consistency of a sample depends on the structure and interaction of the gelling elements in it and to some extent on the viscosity of oil used. The consistency is determined by using Penetrometer. The apparatus consists of

1. Heavy base (of cast iron alloy):

It is one which is provided with spirit level, leveling screws and a plain table, over which a box containing the sample under test is placed.

2. Vertical support is an iron rod fitted to the base. On this are slotted marks, around which a holder can be moved up and down. The holder has a screw, which can be tightened in any of the slots.

3. Circular dial: The holder carries a circular dial gauge, which is graduated in millimeters.

4. Moving dial rod: It is arranged behind the dial by a mechanical mechanism. The rod is provided with a clutch arrangement for disconnecting or connecting it to the circular dial.

5. Mirror: Vertical rod is provided with an adjustable mirror for removing parallax error while positioning the cone or needle in contact with sample surfaces

PROCEDURE:

The apparatus is leveled, the cone or needle cleaned and the sample under-test, in a box, is placed below the cone or needle. The height of the cone or needle is so adjusted, that the tip of the cone or needle just touches the sample. Initial dial reading is noted. The cone is then released for exact 2 sec , by pressing a button is released and final dial reading is noted. The differences of the two dial readings given the penetration. This is repeated for three times and noted the total penetration in 6 sec .

OBSERVATIONS:

TIME (sec)	INITIAL READING OF DIAL d_1 mm	FINAL READING OF DIAL d_2 mm	PENETRATION $d_2 - d_1$ mm

PRECAUTIONS:

1. Level the grease properly.
2. Take the reading without parallel axis error
3. Equipment should be properly cleaned after completing the experiment.

RESULT:

Penetration is found to be decreased with increasing temperature and time

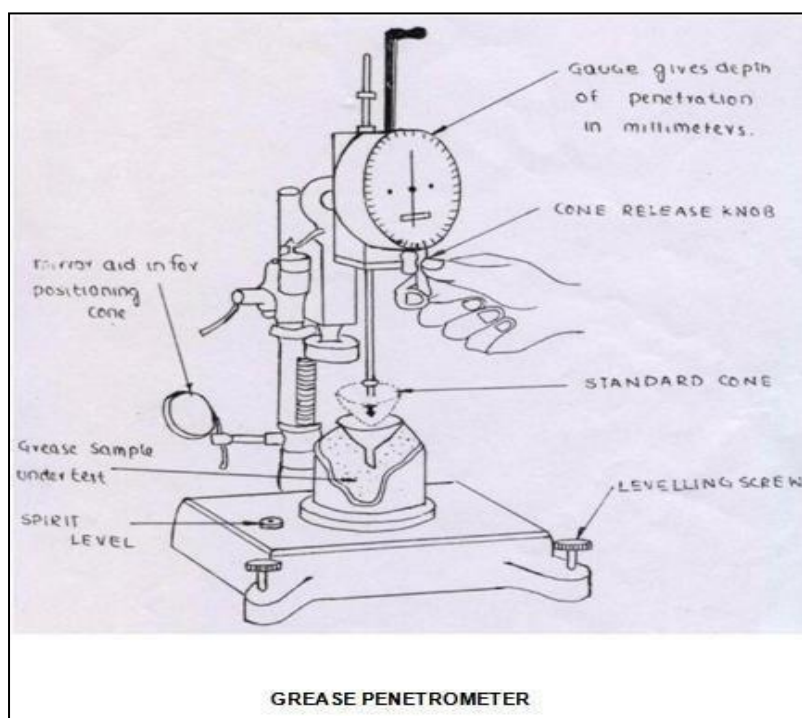

VIVA QUESTIONS

1. Properties of good lubricant?
2. How does viscosity effects lubricants?
3. Units of Calorific value
4. What is the difference between Kinetic Viscosity and Dynamic Viscosity?
5. What is meant by Lubrication?
6. What are the properties of Lubricants?
7. Define Calorific value?
8. Define HCV & LCV?
9. Bomb Calorimeter is used to find the calorific values of which fuels?
10. Junker's calorimeter is used to find the calorific value which fuels?
11. Units of Calorific value?
12. What are the advantages, disadvantages of solid, liquid & gaseous fuels?
13. What are the properties required for a good fuel?
14. Relation between Calorie and Joule?
15. Why stirring is done in viscometer and fire and flash point measuring apparatus?
16. Explain diffusive combustion in detail
17. Explain in detail about stages of combustion in SI engines
18. Explain in detail about stages of combustion in SI engines
19. Explain in detail about knock in SI engines
20. Explain in detail about knock in CI engines

EXPERIMENT -11

ASTM DISTILLATION TEST APPARATUS



AIM:

1. To determine the percentage of distilled amount against temperature of petroleum product sample.
2. To determine the initial and final boiling points of petroleum sample.
3. To determine the quantity of various fractions of petroleum sample.

APPARATUS:

The ISL Distillation Analyzer AD86 5G2 has been designed for the automatic distillation of hydrocarbons under prescribed conditions. A given volume of sample is distilled under appropriate conditions. Temperatures and volumes of condensate and times are systematically recorded. The distillation (or volatility) characteristics are calculated from the resulting data and are in turn used to determine the safety and performance of the sample.

MATERIAL:

100ml Kerosene

INTRODUCTION:

ASTM Distillation is the most common method for obtaining distillation data (volume % distilled vs temperature) of gasoline, naphtha, kerosene and gas oil. In ASTM distillation, 100 ml of sample is distilled at uniform rate of 5ml per min, the distillate is condensed. The temperature of the vapour when the first drop of condensate dripped from the condenser is recorded as the initial boiling point (IBP). The vapour temperature is also recorded as each successive 10% is collected. When 95% has been distilled, the burner flame may need to be increased and the maximum temperature is recorded as the final boiling point (FBP). FBP is an important specification or way of describing gasoline, naphtha or middle distillates.

DEFINITIONS:

Final Boiling Point (FBP): The maximum thermometer reading obtained during the test. Usually occurs after the evaporation of all liquid from the bottom of the flask.

Initial Boiling Point (IBP): The temperature at the instant the first drop falls from the lower end of the condenser tube.

Percent Residue: Percentage volume of residue left in the flask (measured in accordance with the standard in a 5ml flask).

Percent Recovery : Volume measured after 2 minutes interval to successive observations agree (measured in accordance with standard method).

Percent Total Recovery: Combination of percent recovery and percent residue in the flask. Deduct from 100 to obtain percentage loss.

PROCEDURE:

1. Preparation of the analyzer and apparatus
2. Swab the condenser tube using the pull through.
3. Place the ceramic (flask support) board with centered opening on the heating element support.
4. Put small quantity of pumice stone in the flask to stop lathering.
5. Pour the 100ml of prepared sample into the flask, taking care that none of it flows into the vapour tube.
6. Pass the vapour temperature probe through the D86 Flask Stopper, so that the top of the platinum coil of the probe is level with the bottom inner wall of the vapour tube.
7. Adjust the flask in vertical position, fitting the vapour tube (by means of its silicon stopper), so that it extends into the vapour tube between 25 and 50mm.
8. Turn the knob on the bottom of the heating block thus raising up the heating block so that the support boards fits snugly against the flask.
9. Place the provided rubber collar on the projecting lower end of the condenser tube in the receiver chamber.
10. Without drying the graduate, place it with its receiver deflector in position, under the lower end of the condenser tube.
11. The graduations of the graduate should be to the front and the tip of the receiver deflector should be in contact with the front inner wall of the graduate. Make sure the indicator lamp for the detection of the drops is not lit up.
12. Push down the rubber collar (on the end of the condenser tube) to cover the top of the graduate.
13. Close the door of the graduate compartment

OBSERVATION:

Volume Percent distilled	Temperature °C
FBP	

The Final Boiling point of the product = _____^oC

Volume Distilled = _____ mL

Residue left = _____ mL

Evaporated = _____ mL

PRECAUTIONS:

1. There should not be any leakage of vapour fuel from the flask.
2. Collect the pure form of fuel after distillation without any wastage.
3. Clean the flask properly before use to prevent from impurities.

RESULT:

Plot volume percent distilled and temperature

Boiling range points is important property of petroleum products, when we send the products to the industries, they should have information about the properties of the petroleum products and one of them is the boiling range, and also it's important to take careful from the volatile liquid that are dangerous and toxic.

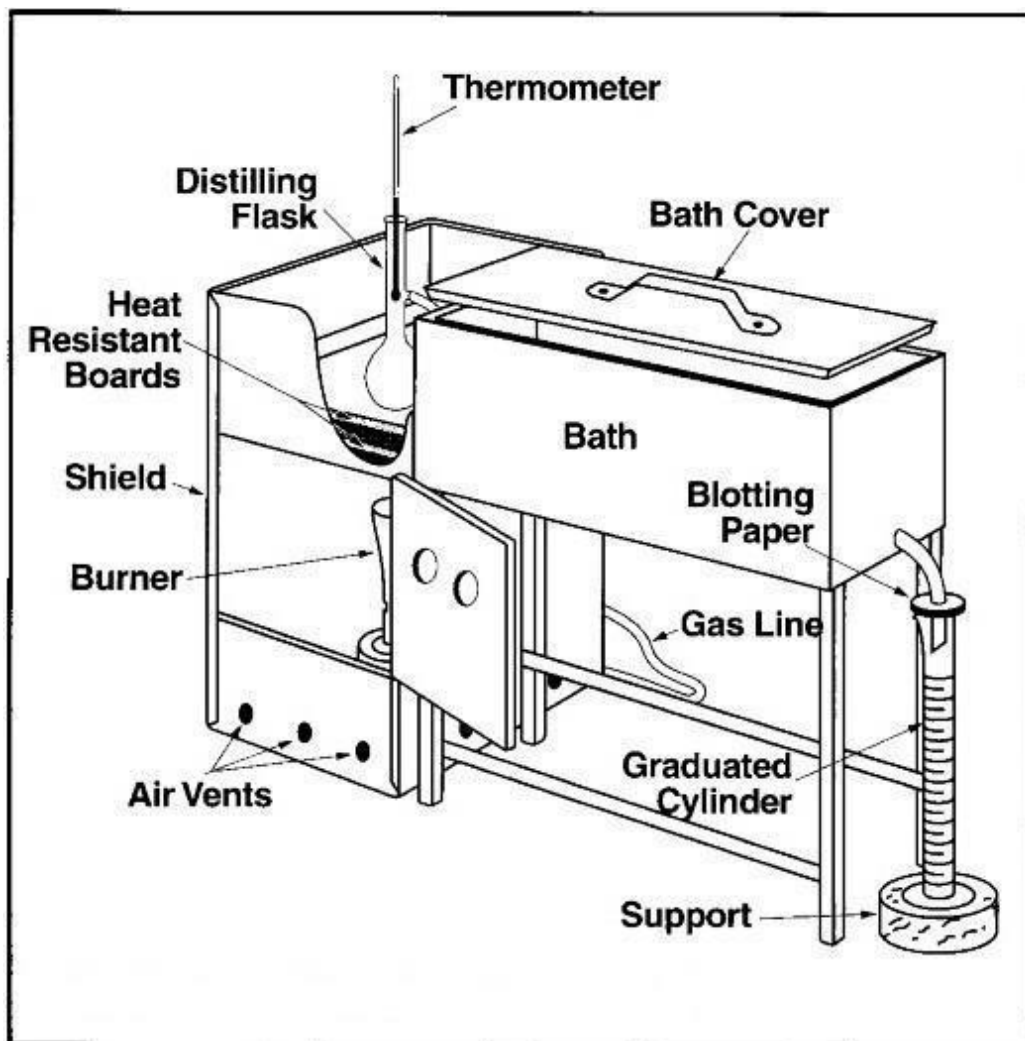

VIVA QUESTION:

1. What information does the boiling range give on the composition, the properties and behavior of the fuel during storage and use ?
2. How can distillation characteristics of hydrocarbon affect their safety and performance?
3. What is the major determinant of the tendency of a hydrocarbon mixture to produce potentially explosive?
4. Give names of three basic liquid fuels
5. Write the general molecular formula for paraffin olefin and naphthene
6. Draw the molecular structure of benzene
7. Draw the molecular structure of toluene
8. Give four important products of petroleum refining process
9. Explain cracking
10. Explain hydrogenation
11. Explain polymerization
12. Explain isomerization
13. Explain cyclization
14. Explain in detail about hydrostatic and hydro dynamic lubrication
15. Explain in detail about wet sump and dry sump lubrication
16. What are the various desired properties of a lubricant and explain how to additives help to achieve the desired properties
17. Explain premixed combustion in detail
18. Explain diffusive combustion in detail
19. Explain premixed combustion in detail
20. Explain diffusive combustion in detail

EXPERIMENT -12

CLOUD & POUR POINT TEST



AIM:

To determine the cloud & pour point of a given fuel / lubricant / oil, using cloud & pour point apparatus

APPARATUS:

Cloud & pour point apparatus, Digital stem thermometer

THEORY:

CLOUD POINT: The temperature, expressed to the nearest degree centigrade, at which a cloud or haze appear when the oil is cooled under prescribed conditions.

POUR POINT: The lowest temperature, expressed as a multiple of 3⁰ c, at which the oil is observed to flow when cooled & examined under prescribed conditions.

PROCEDURE:**CLOUD POINT:**

1. Bring the sample to a temperature of at least 15⁰ C above the approximate cloud point and pour it into the jar to a height of 51 to 57 mm .
2. Close the jar with the cork so that the thermometer bulb rests on the centre of the bottom of the jar.
3. Fit the gasket on to the jar 25 mm from the bottom and insert the jar into gasket.
4. Support the jacket and jar in a vertical position in the bath so that not more than 25 mm projects from the cooling medium.
5. At each thermometer reading of one degree centigrade, remove the jar from the jacket quickly but without disturbing the oil, inspect the material for cloud, and replace the jar, this complete operation shall not take more than 3 sec .
6. If the sample does not show a cloud when it has been cooled 10⁰ C . Place the jar and jacket in another bath maintained at a temperature of -15⁰c to 18⁰ C
7. If the sample does not show a cloud when it has been cooled to -7⁰ C . Place the jar and jacket in another bath maintained at a temperature of -32⁰ C to -35⁰ C .
8. When an inspection of the sample first reveals a distinct cloudiness or haze at the bottom of the jar, record the reading of the thermometer as the cloud point after correcting the thermometer errors if necessary.

POUR POINT:

1. The sample has cooled enough to allow the formation of the crystals.
2. Maintain the bath temperature at -1°C to 2°C
3. Support the jacket and jar in a vertical position in the bath so that not more than 25 mm projects from the cooling medium.
4. Beginning at a temperature 12°C above the expected pour point, at each thermometer reading which is a multiple of 3°C , remove the jar from the jacket carefully, and tilt it just enough to see whether the oil will move and the replace it, this complete operation shall not take more than 3 sec .
5. As soon as the sample ceases to flow when the jar is tilted, hold the jar in horizontal position for exactly 5 sec.
6. If the sample shows any movement replace the jar in the jacket and cool down the sample for another 3°C . If the oil shows no movement during the 5 sec , record the reading of the thermometer.
7. Add 3°C to the temperature recorded above and corrected for thermometer errors if necessary, and note down the result as the pour point.

OBSERVATIONS:

OIL	CLOUD POINT ($^{\circ}\text{C}$)	POUR POINT ($^{\circ}\text{C}$)

PRECAUTIONS:

1. The disc, the gasket, and jacket shall be kept clean and dry.
2. Don't disturb the mass of sample nor don't permit the thermometer to shift in the sample. Any disturbance of the spongy network of crystals will lead to false results.

RESULT:

For a given sample of oil the Cloud & Pour point s are _____ and _____ respectively.

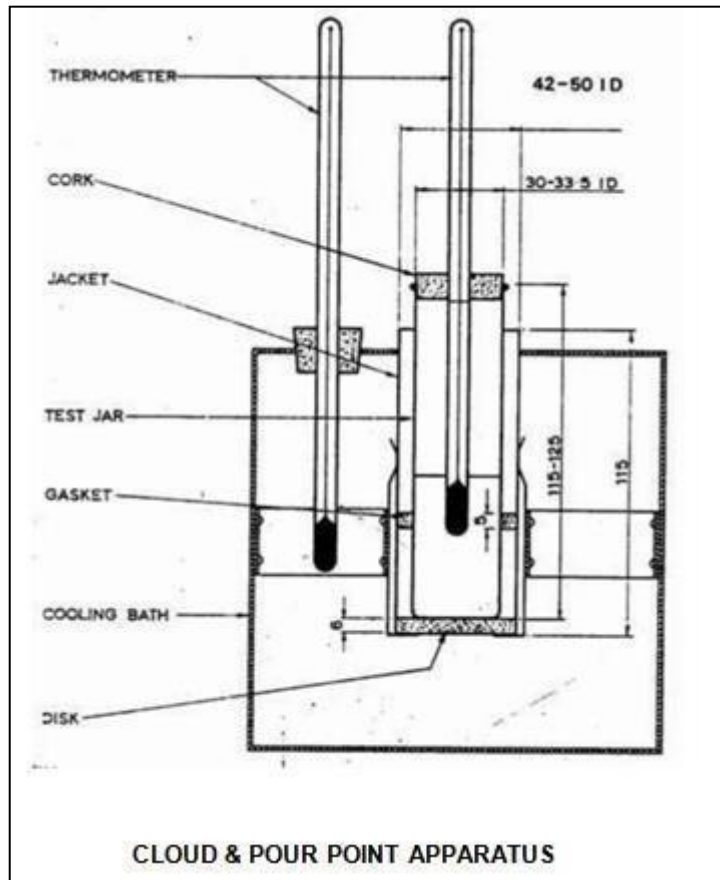

VIVA QUESTIONS:

1. Give names of three basic liquid fuels
2. Write the general molecular formula for paraffin olefin and naphthene
3. Draw the molecular structure of benzene
4. Draw the molecular structure of toluene
5. Give four important products of petroleum refining process
6. Explain cracking
7. Explain hydrogenation
8. Explain polymerization
9. Explain isomerization
10. Explain cyclization
11. Explain reformation
12. Give four required properties of SI engine fuels
13. Give four required properties of CI engine fuels
14. Explain volatility
15. Explain octane number
16. Explain cetane number
17. Give four alternative fuels for SI engines
18. Explain briefly about biodiesel
19. State two advantages of alcohol in SI engine over gasoline
20. What is delay period and what are the factors affecting delay period.