



MARRI LAXMAN REDDY **INSTITUTE OF TECHNOLOGY AND MANAGEMENT**

(AN AUTONOMOUS INSTITUTION)

(Approved by AICTE, New Delhi & Affiliated to JNTUH, Hyderabad)

Accredited by NBA and NAAC with 'A' Grade & Recognized Under Section 2(f) & 12(B) of the UGC act, 1956

DEPARTMENT MECHANICAL ENGINEERING

INSTRUMENTATION AND CONTROL SYSTEMS **LAB MANUAL**



SUBJECT NAME	Instrumentation And Control Systems Lab
SUBJECT CODE	2070384
COURSE-BRANCH	B. Tech - Mechanical Engineering
YEAR-SEMESTER	IV - I
ACADEMIC YEAR	2023-2024
REGULATION	MLRS-R20

MARRI LAXAMAN REDDY

INSTITUTE OF TECHNOLOGY AND MANAGEMENT

MISSION AND VISION OF THE INSTITUTE:

Our Vision:

To establish as an ideal academic institution in the service of the nation the world and the humanity by graduating talented engineers to be ethically strong globally competent by conducting high quality research, developing breakthrough technologies and disseminating and preserving technical knowledge.

Our Mission:

To fulfill the promised vision through the following strategic characteristics and aspirations:

- Contemporary and rigorous educational experiences that develop the engineers and managers;
- An atmosphere that facilitates personal commitment to the educational success of students in an environment that values diversity and community;
- Prudent and accountable resource management;
- Undergraduate programs that integrate global awareness, communication skills and team building across the curriculum;
- Leadership and service to meet society's needs;
- Education and research partnerships with colleges, universities, and industries to graduate education and training that prepares students for interdisciplinary engineering research and advanced problem solving;
- Highly successful alumni who contribute to the profession in the global society.

Vision and Mission statements of the Department of Mechanical Engineering:

Vision Statement:

“The Mechanical Engineering Department strives immense success in the field of education, research and development by nurturing the budding minds of young engineers inventing sets of new designs and new products which may be envisaged as the modalities to bring about a green future for humanity”

Mission Statement:

1. Equipping the students with manifold technical knowledge to make them efficient and independent thinkers and designers in national and international arena.
2. Encouraging students and faculties to be creative and to develop analytical abilities and efficiency in applying theories into practice, to develop and disseminate new knowledge.

3. Pursuing collaborative work in research and development organizations, industrial enterprises, Research and academic institutions of national and international, to introduce new knowledge and methods in engineering teaching and research in order to orient young minds towards industrial development.

PROGRAM EDUCATIONAL OBJECTIVE

PEO 1: Graduates shall have knowledge and skills to succeed as Mechanical engineers for their career development.

PEO 2: Graduates will explore in research.

PEO 3: Mechanical Graduates shall have the ability to design products with various interdisciplinary skills

PEO 4: Graduates will serve the society with their professional skills

PROGRAM OUTCOMES

- A.** Engineering Knowledge: Apply the knowledge of mathematics, science, engineering fundamentals and an engineering specialization for the solution of complex engineering problems.
- B.** Problem Analysis: Identify, formulate, research, review the available literature and analyze complex engineering problems reaching substantiated conclusions using first principles of mathematics, natural science and engineering sciences.
- C.** Design and development of solutions: Design solutions for complex engineering problems and design system components or processes that meet the specific needs with appropriate considerations for public health safety and cultural, societal and environmental considerations.
- D.** Conduct investigations of complex problems: Use research based knowledge and research methods including design of experiments, analysis and interpretation of data and synthesis of the information to provide valid conclusions.
- E.** Modern tool usage: Create, select and apply appropriate techniques, resources and modern engineering and IT tools including predictions and modeling to complex engineering activities with an understanding of the limitations.
- F.** The Engineer and society: Apply reasoning, informed by the contextual knowledge to assess societal, health, safety, legal and cultural issues and the consequent responsibilities relevant to the professional engineering practices.
- G.** Environment and sustainability: Understand the impact of the professional engineering solutions in society and environmental context and demonstrate the knowledge of and need for sustainable development.
- H.** Ethics: Apply ethical principles and commitment to professional ethics, responsibilities and norms of the engineering practice.
- I.** Individual and team work: Function effectively as an individual and as a member or leader in diverse teams and in multi-disciplinary settings.
- J.** Communication: Communicate effectively on complex engineering activities with the engineering community and with the society at large, such as being able to comprehend, write effective reports, design documentation, make effective presentations, give and receive clear instructions.
- K.** Project management and finance: Demonstrate knowledge and understanding of the engineering and management principles and apply these to one's own work, as a member and leader in a team, to manage projects and in multidisciplinary environments.
- L.** Life – long learning: Recognize the need and have the preparation, ability to engage in independent and life – long learning in the broadest context of technological change.

PROGRAMME SPECIFIC OUTCOMES:

PS01: Students acquire necessary technical skills in mechanical engineering that make them employable graduate.

PSO2: An ability to impart technological inputs towards development of society by becoming an entrepreneur.

COURSE OBJECTIVES:

1. Explain the various physical parameters viz., displacement, temperature, pressure, stress, strain, force, torque, power, speed, acceleration, vibrations, flow, level, etc.
2. To address the underlying concepts and methods behind instrumentation and control systems.
3. Instruments required for measuring various parameters are studied in detail
4. Determine various physical parameters that can be effectively used for measurement other physical quantities as a secondary input
5. Design and develop solutions for complex problems of designing system components to meet the needs of a specific instrument
6. Understand in detail instrument characteristics, errors and their elimination

COURSE OUTCOMES:

- | | |
|----------|---|
| ME 384.1 | Analyse errors, integrate and interpret different types of measurements. |
| ME 384.2 | Understand how physical quantities are measured and how they are converted to electrical forms. |
| ME 384.3 | Evaluate the measurement of speed in engineering applications and importance of speed measurement in instrumentation. |
| ME 384.4 | Visualize the areas affected with pressure in equipment and calibrate the pressure measuring devices. |
| ME 384.5 | Comprehend the level of liquid in any container and the various applications of measurement of flow. |
| ME 384.6 | Able to analyse Instrumentation and Control systems and their applications of various industries. |

INSTRUCTIONS TO THE STUDENTS

1. Every student should obtain a copy of the laboratory manual
2. It is important that all students arrive at each session on time.
3. Dress code: Students must come to the laboratory wearing:
 - Trousers.
 - half-sleeve tops.
 - Leather shoes.
 - Half pants, loosely hanging garments and slippers are not allowed.
4. Students should come with thorough preparation for the experiment to be conducted.
5. Students will not be permitted to attend the laboratory unless they bring the practical record fully completed in all respects pertaining to the experiment conducted in the previous class.
6. Experiment should be started only after the staff-in-charge has checked the experimental setup.
7. All the calculations should be made in the observation book. Specimen calculations for one set of readings have to be shown in the practical record.
8. Wherever graphs are to be drawn, A-4 size graphs only should be used and the same should be firmly attached to the practical record.
9. Practical record and observation should be neatly maintained.
10. They should obtain the signature of the staff-in-charge in the observation book after completing each experiment.
11. Theory regarding each experiment should be written in the practical record before procedure in your own words.

LABORATORY SAFETY PRECAUTIONS

1. Laboratory uniform, shoes & safety glasses are compulsory in the lab.
2. Do not touch anything with which you are not completely familiar. Carelessness may not only break the valuable equipment in the lab but may also cause serious injury to you and others in the lab.
3. Please follow instructions precisely as instructed by your supervisor. Do not start the experiment unless your setup is verified & approved by your supervisor.
4. Do not leave the experiments unattended while in progress.
5. Do not crowd around the equipment's & run inside the laboratory.
6. During experiments material may fail and disperse, please wear safety glasses and maintain a safe distance from the experiment.
7. If any part of the equipment fails while being used, report it immediately to your supervisor. Never try to fix the problem yourself because you could further damage the equipment and harm yourself and others in the lab.
8. Keep the work area clear of all materials except those needed for your work and cleanup after your work.

LIST OF EXPERIMENTS

1. Calibration of transducer for temperature measurements.
2. Study and calibration of LVDT transducer for displacement measurements.
3. Calibration of strain gauge
4. Calibration of thermocouple for temperature measurements.
5. Calibration of capacitive transducer for angular displacement.
6. Study and calibration of photo and magnetic speed pickups for the measurement of speed.
7. Calibration of resistance temperature detector for temperature measurements.
8. Study and calibration of Rota meter for flow measurement.
9. Study and use of a Seismic pick up for the measurement of vibration.
10. Study and calibration of McLeod gauge for low pressure.
11. Measurement and Control of Temperature Loop of a Process Using Resistance Temperature Detector With SCADA.
12. Measurement and Control of Flow Loop of a Process Using SCADA Systems.
13. Measurement and Control of Level Loop In a tank Using Capacitive Transducer with SCADA.
14. Measurement and Control of Pressure Loop Using SCADA System.
15. Calibration of pressure gauges.

1. CALIBRATION OF PRESSURE GAUGES

Objective: To Find Out the Pressure of A Given Experiment

Out Come: Will Be Able to Analyze How to Measure the Pressure of a Give Experiment

AIM:

To calibrate the given pressure cell

APPARATUS:

Pressure cell, Dial type pressure indicator, Hydraulic dead weight, Pressure gauge Tester to develop the pressure, Digital pressure indicator.

THEORY:

Pressure is defined as force per unit area and is measured in Newton per square meter (Pascal) or in terms of an equivalent head of some standard liquid (mm of mercury or mater of water). A typical pressure gauge will measure the difference in pressure between two pressure. Thus a pressure gauge is connected to the hydraulic line and the gauge itself stands in atmospheric pressure. The gauge reading will be the difference between the air pressure and the atmospheric pressure and is called gauge pressure. The absolute pressure (the actual pressure within the air line) is the sum of the gauge pressure and atmospheric pressure.

Pressure transducer is basically an electro mechanical devices, especially manufactured and designed or wide range application in pressure measurement. The pressure transducer comprises of diaphragm and an inputs to facilitate pressure measurement. The strain gauges are bonded directly to the sensing member to provide excellent linearity, low hysteresis and repeatability. Fluid medium whose parameter has to be measured is allowed to deflect the diaphragm (sensing member), which is a single block material and forms an integral part of the pressure transducer. It is made up non-magnetic stainless steel and thus has the advantage of avoids the yielding effects and leakage problems. The slight deflection of the diaphragms due to the pressure provided an electrical output.

The material most commonly used for manufacture of diaphragms are steel, phosphor bronze, nickel silver and beryllium copper. The deflection generally follows a linear variation with the diaphragm thickness.

SET UP:

Setup comprises of one Hydraulic Dead weight Pressure gauge tester fitted with analog pressure gauge and pressure cell to be calibrated. Along with calibrated dead weights.

DIGITAL PRESSURE INDICATOR:

Pressure indicator comprises of induct power supply, which provides power for strain gauge excitation. Signal conditioning and amplifying circuits access input from the strain gauges, linearisus and amplifies the signal level. The output of the amplifier is controlled to required level and calibrated to read the pressure in N/Sq Mt. any stray forces on the sensor can be balanced by balancing the strain gauge bridge through potentiometer in the front panel till the display reads zero. The system operates by 230V AC supply.

PANEL DETIALS:

POWER: Rocker switch which switches on the supply of the instrument, indicates with red light.

ZERO: Ten turn potentiometer. The display can be adjusted to read Zero when no force is applied.

CAL: Single turn potentiometer. The output of the amplifier is adjusted by this potentiometer such that the display gives full scale for given range of sensor.

TO SENSOR: Sensor is connected to the indicator through a four core cable with 5 pin socket at sensor end and respective colour connectors.

MAINS INPUT: Power cable. Power cable to be connected to the mains supply of 230V 50Hz.

FUSE: 500 mA cartridge fuse with holder located on the rear side of the instrument to protect the instrument from internal electrical shorting.

CAUTION: Do not remove the fuse cap with power cable plugged to the mains supply.

PROCEDURE:

1. Connect the pressure cell to the pressure indicator given cable.
2. Connect the instrument to mains i.e. 230V. Power supply and switch on the instrument.
3. Adjust the zero pot of the indicator to indicate zero.
4. Close the release valve of pressure gauge tester and apply the 5/10kg dead weight on flange.
5. Slowly rotate the screw road in clockwise direction with the help of handle until flange lift up (so that pressure is developed up to applied load). Now observed

the digital reading. If it is not showing zero then make it zero by rotating ZERO knob. Now instrument is calibrated.

6. Apply the load (up to 10Kgs) on the flange and give pressure by rotating the screw rod.
7. Note down the readings of dial gauge and pressure indicator, simultaneously in every step.
8. Calculate the error if any and % error.

TABLUR COLUMN:

Sl. No	Pressure in Dial gauge, P_c kg / cm ²	Pressure in Digital indicator, P_g kg / cm ²	Correction $P_c - P_g$	Error $P_g - P_c$	% Error $(P_g - P_c) / P_g * 100$

SPECIFICATIONS:

Capacity: 10 Kg / cm²

Type: Strain gauge type

Sensing element: Resistance's strain gauges

Overload: 10% rated capacity

Excitation: 12V D.C

Resistance in Ohms: 350 Ohms typical

Operating temperature: 10° C to 50° C

VIVA QUESTIONS

1. what are applications of advantages a dead weight tester and gauge comparator?
2. how would you select a pressure gauge for a process?
3. Name a few pressure switch manufacturing companies.
4. what is the output of pressure switch?
5. explain the contact on high and low pressure alarm switches and explain ?
6. What is the principle of Thermistor?
7. What is calibration?
8. How Thermistor used for Temperature measurement?
9. What are the advantages of Thermistor?
10. What is the replacement for temperature measurement if Thermistor is not there?

2. CALIBRATION OF RESISTANCE TEMPERATURE DETECTOR FOR TEMPERATURE MEASUREMENT

Objective: To Find Out the Temperature of A Given Experiment

Out Come: Will Be Able To Analyze How to Measure the Temperature of a Give Experiment

AIM:

To calibrate the given RTD by using Thermometer

APPARATUS:

Temperature sensor (RTD), Heating coil to heat water in water bath, Digital temperature Indicator & Thermometer.

THEORY:

RESISTANCE TEMPERATURE DETECTOR (RTD)

Resistance thermometers, also called **resistance temperature detectors or resistive thermal devices (RTD)**, are temperature sensors that exploit the predictable change in electrical resistance of some materials with changing temperature. As they are almost invariably made of platinum, they are often called **platinum resistance thermometers (PTR)**. They are slowly replacing the use of thermocouples in many industrial applications below 600°C, due to higher accuracy and repeatability. There are many categories like carbon resistors, film and wire wound types are the most widely used.

Carbon resistors are widely available and are very inexpensive. They have very reproducible results at low temperatures. They are the most reliable from at extremely low temperatures. They generally do not suffer from significant hysteresis or strain gauge effects.

Film thermometer have a layer of platinum on a substrate, the layer may be extremely thin, perhaps one micrometer. Advantages of this type are relatively low cost and fast response. Such devices have improved performance although the different expansion rates of the substrate and platinum give “strain gauge” effects and stability problems.

Wire – wound thermometers can have greater accuracy, especially for wide temperature ranges.

Coil elements have largely replaced wire wound elements in industry. This design has a wire coil which can expand freely over temperature, held in place by some mechanical support which lets the coil keep its shape.

ADVANTAGES

High accuracy

Low drift

Wide operating range

Suitable for precision applications.

PANEL DETALIS:

POWER ON: Rocker switch which switches on the supply of the instrument, with red light indication.

MIN: Single turn potentiometer. The display can be adjusted to read minimum temperature, when no voltage output from the sensor is measured.

MAX: Single turn potentiometer. The output of the amplifier is adjusted by this pot such that the display reads same as in the given reference temperature. i.e. Thermometer temperature reading.

SELECTOR: Two-position selector switches to select thermistor or RTD sensor.

TERMINALS: Screw type terminals are provided to connect the given Thermister & RTD sensor.

MAINS SUPPLY: Power cable. Power cable to be connected to the mains supply of 230V, 50Hz.

FUSE: 500 mA cartridge fuse with holder located on the rear side of the instrument to protect the instrument from internal electrical shorting.

CAUTION: Do not remove the fuse cap with power cable plugged to the mains supply.

PROCEDURE:

1. Turn the selector switch to the desire position according to the given sensor probe (Thermister / RTD).
2. Connect the given sensor to the temperature display unit.
3. Place the sensor probe and the thermometer into a beaker containing water at room temperature.
4. Connect the power supply to the temperature indicator.
5. Record the room temperature from the thermometer.
6. Adjust the MIN setting knob of the temperature indicator until the display shows the room temperature.

7. Connect the power supply to heating coil and heat the water in the bath.
8. Set the temperature of thermocouple to the thermometer reading when the water is boiling, using MAX knob.
9. Now the given thermocouple is calibrated with reference to thermometer. Record the thermometer reading and the temperature indicator reading simultaneously at regular intervals.

OBSERVATION AND TABULAR COLUMN:

RTD and Thermometer

Sl. no	Temp. of Water by RTD, T_a °C	Temp. of Water by Thermometer, T_m °C	Correction $T_a - T_m$	Error $T_m - T_a$	% Error $(T_m - T_a) / T_m$

GRAPHS:

Draw the following graphs:

T_m v/s T_a

Correction v/s T_m

% Error v/s T_m

VIVA QUESTIONS

1. What instruments are used for temperature measurements?
2. What are standard temperature sensors?
3. Write the Fahrenheit to centigrade temperature conversion formula?
4. What is a thermocouple? How does it work?
5. What is an RTD? How does it work?

6. What is the principle of RTD?
7. What is calibration?
8. How is RTD used for temperature measurement?
9. What are the advantages of RTD?
9. What is the replacement for temperature measurement if RTD is not there?

3.STUDY AND CALIBRATION OF LVDT TRANSDUCER FOR DISPLACEMENT MEASUREMENT

Objective: To Find Out the Measurement of Displacement of A Given Experiment

Out Come: Will Be Able to know How to Measure the Displacement of a Give Experiment

AIM:

To calibrate Linear Variable Differential Transformer (LVDT) for the performance using Micrometer.

APPARATUS:

LVDT, Digital Indicator, Micrometer.

THEORY:

LVDT is an inductive transducer used to translate the linear motion into electrical signal LVDT consists of a single primary winding 'P' and two secondary windings (S1 & S2) wounds on a cylindrical armature. An AC source is connected to the primary winding. A movable soft iron core attached with an arm placed inside the armature.

The primary winding produces and alternating magnetic field which includes alternating voltage in the secondary windings. Single voltage is obtained by connecting the two secondary windings in series. Thus the output voltage of the transducer is the difference of the two voltages.

When the core is at null position, the flux linking with both the secondary windings is equal. Since both the secondary winding have equal number of turns, M the induced emf is same in them. The output voltage is the difference of the two emf say e_1 & E_2 . When they are equal, the voltage is zero at null position.

When the core is moved to the left side from null position more flux links with S1. The output voltage is $V=E_2-E_1$, is greater, the V value is -ve. Means the voltage is read in terms of mm length on the display board indicates the negative value. When the core is moved to the right side of the null position, more flux links with S2 induces voltages which is +ve. The display board indicates the +ve value in mm of length.

The voltage output is linear and is depending on the position of the core. Hence LVDT can be conveniently used to measure the thickness ranging from fraction of a mm to a few cm's. normally LVDT can give better result up to 5mm.

PANEL DETAILS:

POWER ON: Rocker switch which switches on the supply of the instrument, with red light indication.

ZERO: Ten turn potentiometer. The display can be adjusted to read Zero when no force is applied.

CAL: Single turn potentiometer. The output of the amplifier is adjusted by this potentiometer such that the display gives full scale for given range of sensor.

TO SENSOR: Sensor is connected to the indicator through a five core cable with 5 pin respective colour connectors.

MAINS INPUT: Power cable. Power cable to be connected to the mains supply of 230V 50Hz.

FUSE: 500 mA cartridge fuse with holder located on the rear side of the instrument to protect the instrument from internal electrical shorting.

CAUTION: Do not remove the fuse cap with power cable plugged to the mains supply.

PROCEDURE:

The experiment can be carried out for both +ve and –ve sides.

1. Connect the power cable to 230V 50Hz to mains and switch on the instrument.
2. Make the display to read zero (000) by using zero knob.
3. Connect the LVDT cable pins to the instrument with proper colour code.
4. Make the display to read zero by rotating the micrometer. This is called null balancing and note down the micrometer reading.
5. Give the displacement of 5mm by rotating the micrometer from the null position either clockwise or anticlockwise.
6. Then display will read 5.00mm. if not adjust the display by using Cal knob. Now the instrument is calibrated.
7. Again rotate the micrometer to null position and from there take down the reading in steps of 1mm. that is both the sides.
8. Plot the graph micrometer reading v/s display reading (Actual reading v/s Measure reading).

X axis micrometer reading (in mm)

Y axis display reading (in mm)

OBSERVATIONS:

Range of Micrometer.

Least count of Micrometer.

Linearity Range of LVDT.

Least count of LVDT.

Initial reading of Indicator (null position).

Micrometer reading at null position.

TABLUR COLUMN:

Display for +ve side: (clockwise rotation)

Sl. no	Actual Reading, 'R _a ' mm	Measured Reading, 'R _m ' mm	Error 'E'	% Error

Display for -ve side: (anti clockwise rotation)

Sl. no	Actual Reading, 'R _a ' mm	Measured Reading, 'R _m ' mm	Error 'E'	% Error

SPECIMEN CALCULATIONS:

1. R_a = Actual Reading (Pressure gauge reading)
2. R_m = Measured Reading (Indicator reading)
3. 'E' Error = $R_m - R_a$
4. % Error = Error / Actual reading

Graphs:

Actual reading v/s Measured reading (for both +ve & -ve displacements)

VIVA QUESTIONS

1. Mention some of the transducers.

Variable Resistor, Variable inductor, Variable capacitor, Synchros & Resolvers

2. State the advantages of LVDT.

The advantages of LVDT are :- (i) Linearity (ii) Infinite resolution (iii) High output (iv) High sensitivity (v) Ruggedness (vi) Less friction (vii) Less hysteresis (viii) Less power consumption

3. State the disadvantages of LVDT?

The disadvantages of LVDT are (i) Large displacements are necessary for appreciable differential output (ii) They are sensitive to stray magnetic field (iii) Dynamic response is limited by mass of core

(iv) Variation in temperature affects the transducer.

4. Define transducer?

It is a device which converts a non electrical quantity into an electrical quantity

5. What is the pressure transducer?

It is a device which converts the pressure into mechanical displacement which is later converted into electrical quantity using a secondary transducer

6. What is the principle of working of LVDT?

7. What is calibration?

8. How LVDT used for displacement measurement?

9. What are the advantages of LVDT?

10. What is the replacement for displacement measurement if LVDT is not there?

4. MEASUREMENT OF STRAIN GAUGE

Objective: To Find Out the Strain Gauge of A Given Experiment

Out Come: Will Be Able To Analyze How to Measure the Strain Gauge of a Give Experiment

AIM: To determine the elastic constant (modulus of elasticity) of a cantilever beam subjected to concentrated end load by using strain gauges.

APPARATUS: A cantilever beam with concentrated end load arrangement, strain gauges and strain indicator.

THEORY: A body subjected to external forces is in a condition of both stress and strain. Stress can be directly measured but its effect. i.e. change of shape of the body can be measured. If there is a relationship between stress and strain, stresses occurring in a body can be computed if sufficient strain information is available. The constant connecting the stress and strain in elastic material under the direct stresses is the modulus of elasticity,

$$\text{i.e. } E = \sigma / \epsilon$$

the principle of the electrical resistance strain gauge was discovered by Lord Kelvin, when he observed that a stress applied to a metal wire, besides changing resistance strain gauges are made into two basic forms, bonded wire and bonded foil. Wire gauges are sandwiched between two sheets thin paper and foil gauges are sandwiched between two thin sheets of epoxy.

The resistance factor 'R' of a metal depends on its electrical resistivity, ρ , its area, a and the length l , according to the equation $R = \rho l / a$.

Thus to obtain a high resistance gauge occupying a small area, the metal chosen has a high resistivity, a large number of grid loops and a very small cross sectional area. The most common material for strain gauge is a copper - nickel alloy known as Advance.

The strain gauge is connected to the material in which it is required to measure the strain, with a thin coat of adhesive. Most common adhesive used is Eastman, Deco Cement, etc. as the test specimens extends or contracts under stress in the direction of windings, the length and cross sectional area of the conductor alter, resulting in a corresponding increase or decrease in electrical resistance.

GAUGE FACTOR:

The dimension less relationship between the change in gauge resistance and change in length is called Gauge factor of the strain, which is expressed mathematically,

$$\text{Gauge Factor, } g = (\Delta R / R) / (\Delta l / l)$$

In this relationship R and l represent, respectively the initial resistance and initial length of the strain gauge filament, while ΔR & Δl represents the small change in resistance and length, which occurs as the gauge is strained along with the surface to which it is bonded. This gauge factor of a gauge is a measure of the amount of resistance change for a given strain. The higher the gauge factor greater the electrical output for indication or recording purpose. The gauge factor is supplied by the manufacturer and may range from 1.7 to 4.

The usual method of measuring the change of resistance in a gauge element is by means of Wheatstone bridge as shown in figure. It consists of Galvanometer, 4 resistor & a battery. Resistance R_1 is the strain gauge is used for strain measurement, which is mounted on the specimen. The three resistors R_2 , R_3 and R_4 are internal to the device.

Let us assume that the resistance have been adjusted so that the bridge is balanced.

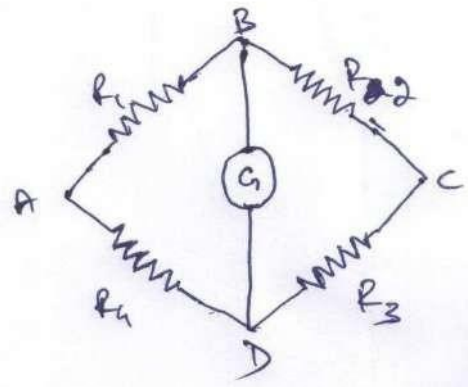

Voltage $E_{bd} = 0$.

Thus for initial balance, $R_1 * R_3 = R_2 * R_4$

Or

$$R_1 = (R_2 * R_4) / R_3$$

If the structural member, to whom the strain gauge is bonded, is to be loaded and strained, there would be a resultant change in the resistance R_1 .

According to the relationship,

$$R = R_1 (1 + g * \epsilon)$$

The strain indicator is calibrated for gauges of a given factor, thus it provides accurate reading only when gauges having the same gauge factor are used.

The most common bridge arrangements are single arm, two arm and four arm mode.

Single Arm Mode (Quarter bridge).

This bridge arrangement consists of a single active gauge in position, say R_1 and three resistors are internal to the device. Temperature compensation is possible only if a self temperature compensating strain gauge is used.

Two Arm Mode (Half bridge).

In this mode, two resistors are internal to the device and the remaining two are strain gauges. One arm of this bridge is commonly labeled as active arm and the other as compensating arm. The bridge is temperature compensated.

Four Arm Mode (Full bridge).

In this bridge arrangement, four active gauges are placed in the bridge with one gauge in each of the four arms. If the gauges are placed on a beam in bending as shown in fig of the elastic constant by bending test experiment, the signal from each of the four gauges will add. This bridge arrangement is temperature compensated.

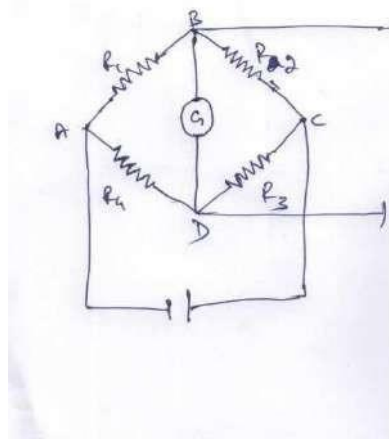

Consider a cantilever beam as shown in fig. Let,

W = load applied on the beam in N.

l = distance between the center of the gauge to the point of application of load.

b = width of the beam in mm.

h = thickness of the beam in mm.

M_b = bending moment = WL in N-mm.

I = moment of inertia = $bh^3 / 12$ mm⁴

c = $h/2$ mm.

The bending equation is,

$$M_b / I = \sigma / c$$

Bending stress, $\sigma = M_b c / I$.

$$WI * h/2 * 12 / bh^3 = 6WI / bh^2.$$

Let,

ϵ = strain indicator reading in micro strain.

i = number of active gauges.

$$\text{Measured strain, } (\epsilon_m) = \epsilon * 10^{-5} / i$$

$$\begin{aligned} \text{Modulus of elasticity, } E &= \sigma / \epsilon_m \\ &= 6WI / bh^3 \epsilon_m \end{aligned}$$

The strain gauges R1, R3 measure the tensile strain while the gauges R₂, R₄ measure the compressive strains. The strains ϵ_1 , ϵ_2 , ϵ_3 and ϵ_4 as measured by the gauges are of equal magnitude. The bridge in this said to be working as full bridge and sensitivity (out put) is four times that achievable with a single active gauge.

SET UP:

The set up comprises of cantilever beam made up of mild steel material. Square pipe with opening at one end the other end land for fixing the beam. Bottom of the square pipe has got a provision for fixing the sensor rigidly to the table. A loading pan is provided to load the sensor. Weights up to 1Kg in steps of 10gms will be provided with the setup. Specimen with strain gauges of 120 ohms are bonded on the material and connected in the form of wheat stones bridge and the terminals are brought out through a connector.

DIGITAL STRAIN INDICATOR

Strain indicator comprises of induct power supply, which provides power for strain gauge excitation. Signal conditioning and amplifying circuit's access input from the strain gauges linearisus and amplifies the signal level. The output

of the amplifier is controlled to required level and calibrated to read the strain in micro strain. Any stray forces on the sensor can be balanced by balancing the strain gauge bridge through pot in the front panel till the display reads zero. The system operates by 230V AC supply.

SPECIFICATION OF CANTELIVER BEAM SET UP

Capacity	: 1kg
Type	: Strain gauge based.
Strain gauge	: Foil type, 120ohms.
Gauge factor	2
Weights	: 100gms – 10 Nos.
Beam material	: Mild steel.
Beam width	: 41mm.
Beam thickness	: 2.85mm.

STRAIN INDICATOR

Display	: 3 ½ digital, LED displays.
Accuracy	: 1.
Resolution	: 1 s.
Connection	: Through 4 cores shielded cable.
Power required	: 230V, 50hz

PANEL CETAELS

POWER ON: Rocker switch which switches on the supply of the instrument, with red light indication.

ZERO: Ten turn potentiometer. The display can be adjusted to read Zero when no force is applied.

CAL: Single turn potentiometer. The output of the amplifier is adjusted by this potentiometer such that the display gives full scale for given range of sensor.

TO SENSOR: Sensor is connected to the indicator through a four core cable with core male pins at both ends and respective color connections at the other end to connect the instrument.

FUNCTION: Three position rotary switches is provided to select GF position READ position and CAL position. In READ position display will read directly Micro strain which load applied on the cantilever beam. In CAL position display will read maximum calibrated point i.e. 1000. In GF position display gauge factor i.e. 500

ARM: selector switch is to select the ARM are provided on the panel i.e. 4, 2 & 1.

MAINS INPUT: Power cable. Power cable to be connected to the mains supply of 230V 50Hz.

FUSE: 500 mA cartridge fuse with holder located on the rear side of the instrument to protect the instrument from internal electrical shorting.

CAUTION: Do not remove the fuse cap with power cable plugged to the mains supply.

PROCEDURE:

STRAIN MEASUREMENT IN FOUR ARM MODES (FULL BRIDGE)

1. Switch on the instrument and leave 5 minutes to warm up.
2. Connect the sensor (Cantilever beam) to instrument by 4 core cable with respective colored pins.
3. Keep the ARM selector switch to 4 positions.
4. Select the FUNCTION switch to GF position and adjust the display to read 500 by GF pot.
5. Select the FUNCTION switch to READ position and adjust the display to read zero by zero pot.
6. Select the FUNCTION switch to CAL position and adjust the display to read 1000 by CAL pot.
7. Apply the load on cantilever beam, in steps of 100 grams and note down the readings.

TABULAR COLUMN FOR FULL BRIDGE

Sl. No	Load Applied W (N)		Strain Indicator Reading ϵ – micro strain	Measured Strain $\epsilon_m = \epsilon * 10^{-6}$ /	Bending stress. $\sigma = 6wl / bh^2$	Modulus of elasticity. $E = \sigma / \epsilon_m$ (N/nm ²)
	W	N				

STRAIN MEASUREMENT IN TWO ARM MODES (HALF BRIDGE)

1. Switch on the instrument and leave 5 minutes to warm up.
2. Connect the sensor (Cantilever beam) to instrument by 4 core cable with respective colored pins.
3. Keep the ARM selector switch to 4 positions.
4. Select the FUNCTION switch to GF position and adjust the display to read 500 by GF pot.
5. Select the FUNCTION switch to READ position and adjust the display to read zero by zero pot.
6. Select the FUNCTION switch to CAL position and adjust the display to read 1000 by CAL pot.
7. Apply the load on cantilever beam, in steps of 100 grams and note down the readings.

TABULAR COLUMN FOR HALF BRIDGE

Sl. No	Load Applied W (N)		Strain Indicator Reading ϵ – micro strain	Measured Strain $\epsilon_m = \epsilon * 10^{-6} / 2$	Bending stress. $\sigma = 6wl / bh^2$	Modulus of elasticity. $E = \sigma / \epsilon_m$ (N/nm ²)
	W	N				

STRAIN MEASUREMENT IN ONE ARM MODES (QUARTER BRIDGE)

1. Switch on the instrument and leave 5 minutes to warm up.
2. Connect the sensor (Cantilever beam) to instrument by 4 core cable with respective colored pins.
3. Keep the ARM selector switch to 4 positions.
4. Select the FUNCTION switch to GF position and adjust the display to read 500 by GF pot.
5. Select the FUNCTION switch to READ position and adjust the display to read zero by zero pot.
6. Select the FUNCTION switch to CAL position and adjust the display to read 1000 by CAL pot.
7. Apply the load on cantilever beam, in steps of 100 grams and note down the readings.

TABULAR COLUMN FOR QUATER BRIDGE

Sl. No	Load Applied W (N)		Strain Indicator Reading ϵ – micro strain	Measured Strain $\epsilon_m = \epsilon * 10^{-6} / 1$	Bending stress. $\sigma = 6wl / bh^2$	Modulus of elasticity. $E = \sigma / \epsilon_m$ (N/nm ²)
	W	N				

VIVA QUESTIONS

5. CALIBRATION OF THERMOCOUPLE FOR TEMPERATURE MEASUREMENT

Objective: To Find out the Temperature of A Given Experiment

Out Come: Will Be Able to Analyze How to Measure the Temperature of a Give Experiment

Aim:

To calibrate the given thermocouple using thermometer

APPARATUS:

Thermocouple, a heating coil to heat the water in the water bath, thermometer and a digital indicator to indicate the temperature of thermocouple.

THEORY:

The common electrical method of temperature measurement uses the thermocouple, when two dissimilar metal wires are joined at both ends, an emf will exist between the two junctions, if the two junctions are at different temperatures. This phenomenon is called Setback effect. If the temperature of one junction is known then the temperature of the other junction may be easily calculated using the thermoelectric properties of the materials. The known temperature is called reference temperature and is usually the temperature of ice. Potential (emf) is also obtained if a temperature gradient along the metal wires. This is called Thomson effect and is generally neglected in the temperature measuring process. If two materials are connected to an external circuit in such a way that current is drawn, an emf will be produced. This is called as Peltier effect. In temperature measurement, setback emf is of prime concern since it is dependent on junction temperature.

The thermocouple material must be homogeneous. A list of common Thermocouple materials in decreasing order of emf chrome, iron and copper platinum – 10% rhodium, platinum, alumel and constantan (60% copper and 40% nickel). Each material is thermoelectrically positive with respect to the below it and negatives with respect those above.

The material used in the Thermocouple probe is:

1. Iron – Constantan (Type J)
2. Copper – Constantan (Type T)
3. Chromyl – Alumel (Type K)

SETUP:

Setup comprises of thermometer as a reference and three types of Thermocouples as mentioned above, to be calibrated. The entire sensor can be placed in a hot bath where the water can be heated up to boiling temperature through heating coil. Heater of capacity 500 watts is provided which will be connected to the 230V, 50Hz. power supply through three-pin mains cord.

DIGITAL TEMPERATURE INDICATOR:

Temperature indicators for thermocouples are provided in a unit with digital display. For thermocouples, the output of the sensor (i.e. in mV) is amplified through electronic circuits. Calibration provision is provided out to calibrate any sensor required. RTD sensor is calibrated and the output in terms temperature in degree centigrade is displayed.

PANEL DETAILS:

POWER ON: Rocker switch which switches on the supply of the instrument, with red light indication.

MIN: Single turn potentiometer. The display can be adjusted to read minimum temperature, when no voltage output from the sensor is measured.

MAX: Single turn potentiometer. The output of the amplifier is adjusted by this pot such that the display reads same as in the given reference temperature. i.e. Thermometer temperature reading.

SELECTOR: Two-position selector switches to select Temperature or mV output of the sensor.

SELECTOR: Three- position selector switches to select J-type / K-type / T-type thermocouples.

TERMINALS: Screw type terminals are provided to connect the given thermocouples.

MAINS SUPPLY: Power cable. Power cable to be connected to the mains supply of 230V, 50Hz.

FUSE: 500 mA cartridge fuse with holder located on the rear side of the instrument to protect the instrument from internal electrical shorting.

CAUTION: Do not remove the fuse cap with power cable plugged to the mains supply.

PROCEDURE:

1. Turn the type selector to the desire position according to the given T.C probe.
2. Connect the given thermocouple to the temperature display unit.
3. Place the thermocouple and the thermometer into a beaker containing water at room temperature.
4. Connect the power supply to the temperature indicator.
5. Record the room temperature from the thermometer.
6. Adjust the MIN setting knob of the temperature indicator until the display shows the room temperature.
7. Connect the power supply to heating coil and heat the water in the bath.
8. Set the temperature of thermocouple to the thermometer reading when the water is boiling, using MAX knob.
9. Now the given thermocouple is calibrated with reference to thermometer. Record the thermometer reading and the temperature indicator reading simultaneously at regular intervals.

OBSERVATION AND TABULAR COLUMN:

Material for thermocouple wires =

Sl. no	Temp. of Water by Thermometer, T_a °C	Temp. of Water by Thermocouple, T_m °C	Correction $T_a - T_m$	Error $T_m - T_a$	% Error $(T_m - T_a) / T_m$

GRAPHS:

Draw the following graphs:

1. T_m Vs T_a
2. Correction Vs T_m
3. % Error Vs T_m

VIVA QUESTIONS

1. What is the working principle of a thermocouple?
2. What is a thermocouple & how does it work?
3. What are the major advantages of a thermocouple?
4. What are the major disadvantages of a thermocouple?
5. What is a piezoelectric transducer?
6. What is the principle of Thermocouple?
7. What is calibration?
8. How Thermocouple used for Temperature measurement and what is the range of thermocouples?
9. What are the advantages of Thermocouple?

6. MEASUREMENT OF ANGULAR DISPLACEMENT USING CAPACITIVE TRANSDUCER

Objective: To Find Out the angular displacement of A Given Experiment

Out Come: Will Be Able to Analyze How to Measure the angular displacement of a Give Experiment

AIM:

Measurement of angular displacement using capacitive transducer

APPARATUS:

Capacitive transducer & Angular displacement indicator

THEORY:

Capacitance is well known to be a function of effective area of the conductors, separation between them, and the dielectric strength of the material in the separation. Capacitive transducers convert the physical quantity to be measured into a change of capacitance which is processed by the measuring circuit of the transducer. The capacitance of a parallel plate capacitor may be changed by varying the separation between the plates, varying the effective area of the plates or varying the dielectric.

Capacitive type transducers are used essentially for displacement or positioning measurements. But they are more susceptible to environmental factors such as dust or moisture in the atmosphere than inductive type transducers.

The meshing area between two stator and rotor plates of the capacitor goes on changing as the shaft capacitor is rotated. The arrangement is used to demonstrate the measurement of angular displacement.

The transducer is mounted on to the face of a protractor which indicates the angle of displacement and the readout display the amount of displacement.

PROCEDURE:

Connect the power card to the 230V AC mains & switch on the instrument.

Connect the capacitive transducer to the angular displacement indicator with proper color codes of the pins.

Rotate the transducer knob to zero position. Now display shows the zero.

Rotate the transducer knob to any angle (Ex. 90 deg) and the reading of the display should be same. If not, then adjust by rotating the CAL POT.

TABULAR COLUMN:

Sl. no	The displacement protractor reading	Measured displacement meter reading	Deviation

GRAPH: Plot a graph using the true displacement on X axis & measured displacement on Y axis.

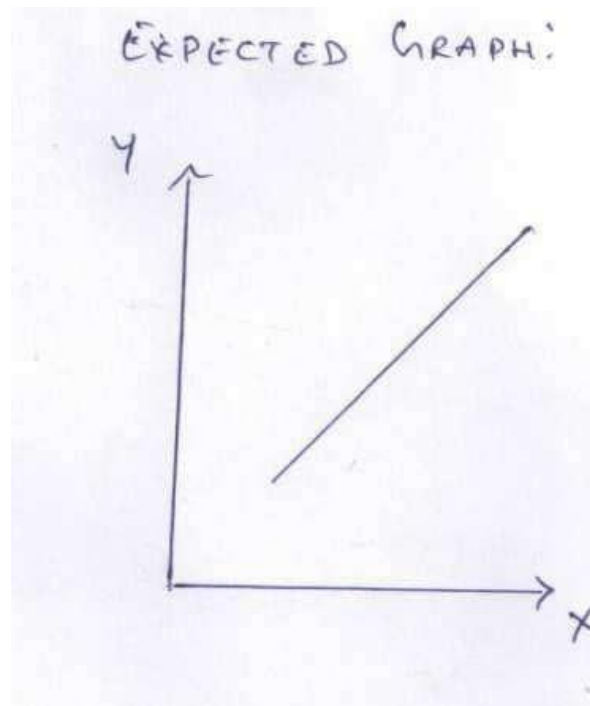

VIVA QUESTIONS

1. Angular displacement is defined by units (revolution/radian)
2. One radian is equal to an angle of 57.3°
3. One revolution is equal to an angle of 360°
4. For very small values of angles, angular displacement is a vector quantity
5. Rate at which angular displacement changes with time is called angular velocity
6. In the SI system, angular velocity is measured in radians per second
7. Revolution per minute is the SI unit of angular velocity
8. What is calibration?
9. How is a capacitive transducer used for displacement measurement?
10. What is the principle of working of a capacitive transducer?
11. What are the advantages of a capacitive transducer?
12. What is the replacement for displacement measurement if a capacitive transducer is not there?
- 13.
- 14.
- 15.
- 16.
- 17.
- 18.
- 19.
- 20.
- 21.
- 22.
- 23.
- 24.
- 25.
- 26.
- 27.
- 28.
- 29.
- 30.

7 . STUDY AND CALIBRATION OF PHOTO AND MAGNETIC SPEED PICKUPS FOR THE MEASUREMENT OF SPEED

Objective: To Find Out the magnetic & photo speed of A Given Experiment

Out Come: Will Be Able To Analyze How to Measure the magnetic & photo speed of a Give Experiment.

The measurement of rotational velocity is more common. For velocity (speed) measurement the most convenient calibrator scheme uses a combination of toothed wheel, a simple magnetic proximity pickup a photo couple sensor and an electronic indicator to measure the speed. The angular rotation is provided by some adjustable speed drive of adequate stability. The toothed wheel mounted with iron rods while passing under magnetic and photo pickup produces an electric pulse. These pulse are fed to signal conditioner unit and displays reading visually. The stability of the rotational drive is easily checked by observing the variation of display reading.

CONTROL AND OPERATION:

Speed measurement system is provided with display or signal conditioner unit and sensor unit. Sensor unit consist of magnetic and photo pick up unit with variable speed controller and a AC motor. The pulses generated by pickup sensor is sensed by signal conditioner.

Refer the front panel of the instrument, it is provided with toggle switch to select the mode of display reading by magnetic or photo pickup display reads the speed in RPM.

Also provided with sensor socket for connecting magnetic and photo pickup units. Back panel of the instrument is provided with power on switch, fuse holder and power chord for connecting AC supply.

OPERATION:

1. Connect the indicator to 230V AC main and motor to variac.
2. Arrange the sensor (magnetic & photo) suitable so that it is mounted properly to sense the pulses.
3. Connect the sensor to instrument.
4. Switch ON the instrument and note the reading in display in no velocity mode the display has to be zero.
5. Vary the speed of motor by variac and note the reading in digital display.
6. By selecting toggle switch we can note the speed reading of either magnetic or photo pickup sensors.

TABULAR COLUMN:

SNo	MAGNETIC SPEED PICK UP	PHOTO SPEED PICK UP	SPEED MEASURED BY TACHOMETER	ERROR OF MAGNETIC SPEED PICK UP	ERROR PHOTO SPEED PICK UP

VIVA QUESTIONS

1. What is a photoelectric pickup & how does it work?
2. How does a photoelectric pickup work?
3. What is Torque?
4. What is a torque meter?
5. How does a torque meter work?
6. What is the formula of photoelectric pickup?

7. What is the Principle of Stroboscope?
8. What are the applications of Stroboscope?
9. Specifications of Stroboscope?
10. What are the Applications of Stroboscope?
11. What are the advantages and disadvantages of Stroboscope?

8. CALIBRATION OF THERMISTER AND RTD

Objective: To Find Out the Temperature of A Given Experiment

Out Come: Will Be Able To Analyze How to Measure the Temperature of a Give Experiment

AIM:

To calibrate the given Thermister & RTD by using Thermometer

APPARATUS

Temperature sensor (Thermister & RTD), Heating coil to heat water in water bath, Digital temperature Indicator & Thermometer

THEORY:

A Thermister is a type of resistor whose resistance varies significantly with temperature, more so than in standard resistors. The word is a portmanteau of thermal and resistor. Thermister are widely used as inrush current limiters, temperature sensor, self-resetting over current protectors and self-regulating heating elements. Thermister differ from resistance temperature detectors (RTD) in that the material used in a Thermister is generally a ceramic or polymer, while RTD's use pure metals. The temperature response is also different, RDT's are useful over larger temperature ranges, while Thermister typically achieve a higher precision within a limited temperature range (usually – 90 °C to 130 °C).

Assuming, as a first order approximation, that the relationship between and temperature is linear, then

$$\Delta R = k \Delta T$$

Where,

ΔR = change in resistance

ΔT = change in temperature

k = first order temperature co-efficient of resistance

Thermister can be classified into two types, depending on the sign of k. if k is positive, the resistance increases with increasing temperature, and the device is called a positive temperature co-efficient (PTC) Thermister or posistor. If k is negative, the resistance decreases with increasing temperature, and the device is called a negative temperature co-efficient (NTC) thermistor. Resistors that are not thermistor are designed to have a k as close to zero as possible, so that their resistance remains nearly constant over a wide temperature range.

RESISTANCE TEMPERATURE DETECTOR (RTD):

Resistance thermometers, also called **resistance temperature detectors or resistive thermal devices (RTD)**, are temperature sensors that exploit the predictable change in electrical resistance of some materials with changing temperature. As they are almost invariably made of platinum, they are often called **platinum resistance thermometers (PTR)**. They are slowly replacing the use of thermocouples in many industrial applications below 600°C, due to higher accuracy and repeatability. There are many categories like carbon resistors, film and wire wound types are the most widely used.

Carbon resistors are widely available and are very inexpensive. They have very reproducible results at low temperatures. They are the most reliable from at extremely low temperatures. They generally do not suffer from significant hysteresis or strain gauge effects.

Film thermometer have a layer of platinum on a substrate, the layer may be extremely thin, perhaps one micrometer. Advantage of this type is relatively low cost and fast response. Such devices have improved performance although the different expansion rates of the substrate and platinum give “strain gauge” effects and stability problems.

Wire – wound thermometers can have greater accuracy, especially for wide temperature ranges.

Coil elements have largely replaced wire wound elements in industry. This design has a wire coil which can expand freely over temperature, held in place by some mechanical support which lets the coil keep its shape.

ADVANTAGES:

High accuracy

Low drift

Wide operating range

Suitable for precision applications.

PANEL DETALIS:

POWER ON: Rocker switch which switches on the supply of the instrument, with red light indication.

MIN: Single turn potentiometer. The display can be adjusted to read minimum temperature, when no voltage output from the sensor is measured.

MAX: Single turn potentiometer. The output of the amplifier is adjusted by this pot such that the display reads same as in the given reference temperature. i.e. Thermometer temperature reading.

SELECTOR: Two-position selector switches to select thermistor or RTD sensor.

TERMINALS: Screw type terminals are provided to connect the given Thermister & RTD sensor.

MAINS SUPPLY: Power cable. Power cable to be connected to the mains supply of 230V, 50Hz

FUSE: 500 mA cartridge fuse with holder located on the rear side of the instrument to protect the instrument from internal electrical shorting.

CAUTION: Do not remove the fuse cap with power cable plugged to the mains supply.

PROCEDURE:

1. Turn the selector switch to the desire position according to the given sensor probe (Thermister / RTD).
2. Connect the given sensor to the temperature display unit.
3. Place the sensor probe and the thermometer into a beaker containing water at room temperature.
4. Connect the power supply to the temperature indicator.
5. Record the room temperature from the thermometer.

6. Adjust the MIN setting knob of the temperature indicator until the display shows the room temperature.
7. Connect the power supply to heating coil and heat the water in the bath.
8. Set the temperature of thermocouple to the thermometer reading when the water is boiling, using MAX knob.
9. Now the given thermocouple is calibrated with reference to thermometer. Record the thermometer reading and the temperature indicator reading simultaneously at regular intervals.

OBSERVATION AND TABULAR COLUMN:

Thermister and Thermometer

Sl. no	Temp. of Water by Thermometer, T_a °C	Temp. of Water by Thermister, T_m °C	Correction $T_a - T_m$	Error $T_m - T_a$	% Error $(T_m - T_a) / T_m$

RTD and Thermometer

Sl. no	Temp. of Water by Thermometer, T_a °C	Temp. of Water by Thermister, T_m °C	Correction $T_a - T_m$	Error $T_m - T_a$	% Error $(T_m - T_a) / T_m$

GRAPHS:

Draw the following graphs:

T_m v/s T_a

Correction v/s T_m

% Error v/s T_m

VIVA QUESTIONS

1. what is RTD and thermister?
2. Are RTDs and thermocouples intrinsically safe?
3. What are the major differences between a thermocouple and an RTD?
4. What are the major advantages of RTD?
5. What is a thermocouple & how does it work?

9 .CALIBRATION OF ROTAMETER

AIM :

To measure rate of flow of liquid using Rotameter.

APPARATUS:

1. Rotameter.
2. Fluid source (Pipe line), Outlet pipe, Valve, Container.
3. Rotameter tab with engraved scale.
4. Scale range 0 to 0.05 m³ / min or 50 lit / min.
5. Least count of scale – 2 lit / min.
6. Suitable for measuring liquids.
7. Float material – Stainless steel or any non-Corrosive metal.
8. Suitable arrangement for inlet and outlet connections with valves on both the sides.

Theory:

The rotameter is the most popular flowmeter. It consists essentially of a plummet or float which is free to move up or down in a vertical slightly tapered tube having its small end down. The fluid enters the lower end of the tube and causes the float to rise until the annular area between the tube and the float is such that the pressure drop across this construction is just sufficient to support the float. Typically, the tapered tube is of glass and carries etched upon it a nearly linear scale on which the position of the float may be usually noted as an indication of the flow.

Rotameter have proved satisfactory both for gasses and for liquids at high and low pressures. Rotameter required straight runs of pipe before or after the point of installation. Pressure losses are substantially constant over the whole flow range. In experimental work, for greatest precision, a rotameter should be calibrated with the fluid which is to be entered. However, most modern rotameters are precision-mode such that their performance closely corresponds to a mater calibration plate for the type in question.

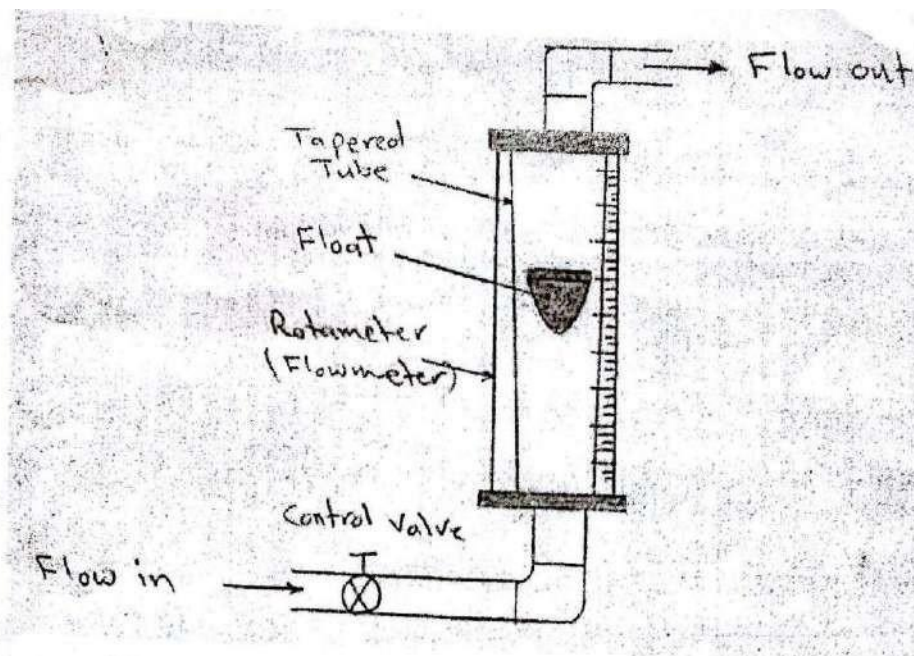

Fig. (1). Rotameter.

Procedures:

1. Select a rate of fluid flow through the rotameter.
2. Opening the inlet valve till the float reaches the selected flow rate.
3. Estimating the time required to fill a fixed volume of output water.
4. The rotameter reading indicates the rotameter flow rate ($Q_{rot.}$) in (L/min); while the volume selected divided by the time measured indicates the actual flow rate ($Q_{act.}$) in (L/sec).
5. Repeating the procedures from 1 to 3 for other selecting flow rate.

Calculation and Results:

The actual volume flow rate is found from dividing the selected volume of water by the time required to accumulate that volume,

$$Q_{act.} = \frac{V}{t} = \frac{A \times h}{t} = \frac{0.277 \times h}{t} \quad \text{in (m}^3/\text{s)} \quad (1)$$

Where

V : is the volume of the water output accumulated in the storage tank, m^3 .

t : is the time it takes to fill the selected volume, sec.

A : is the cross-section area of the storage tank,

h : is the height of water in the storage tank, m.

$$1\text{LPM} = 0.000017 \text{ m}^3/\text{sec}$$

Record the selected value of rotameter and estimated value of actual flow rate in a table as shown in table below.

No.	Q_{rot} (m^3/sec)	h (cm)	t (sec)	V (m^3)	$Q_{act.}$ (m^3/sec)	$C_f = Q_{rot} / Q_{act.}$
1.						
2.						
3.						
4.						
5.						
6.						

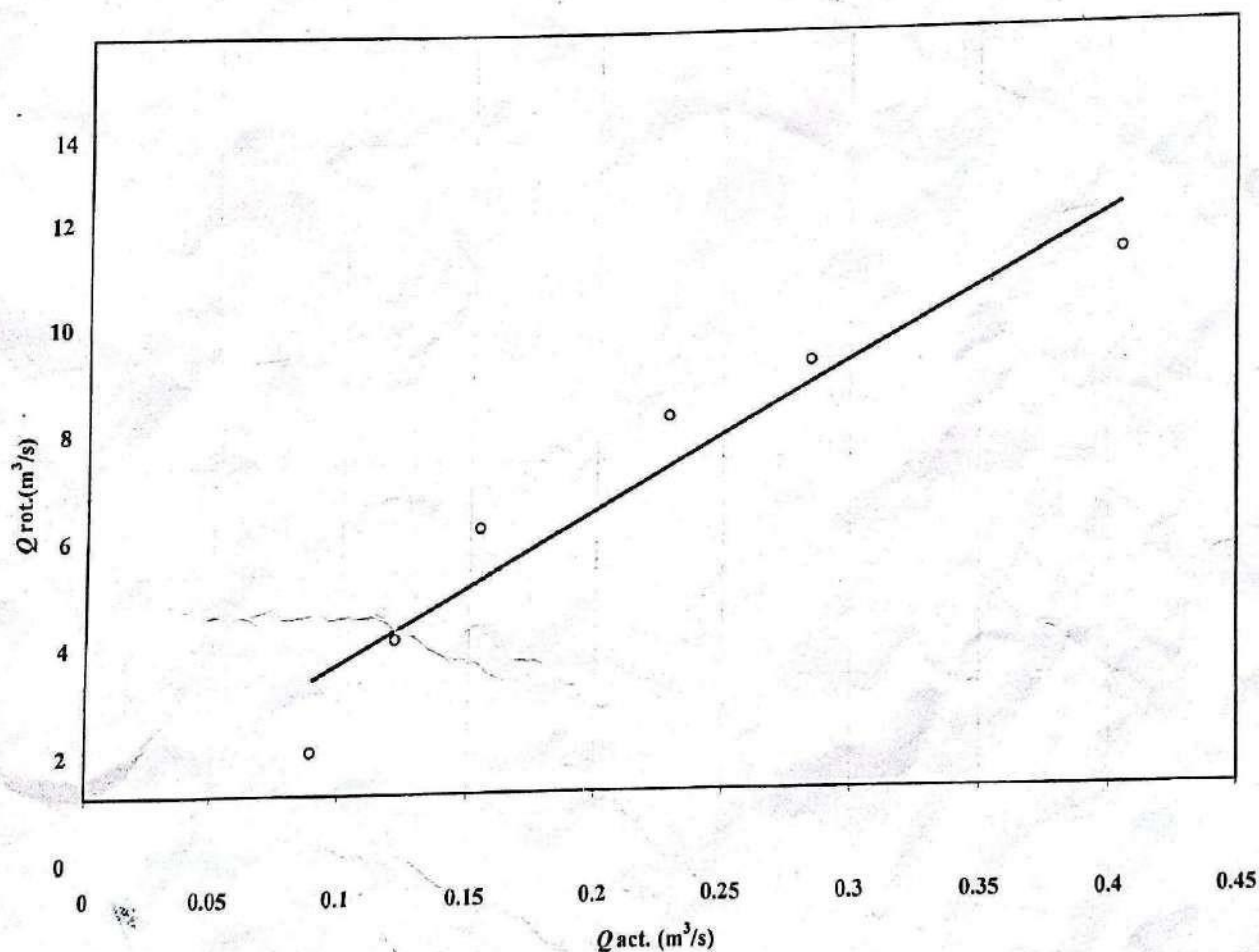

Fig. (2). Calibration curve for rotameter.

Calculating correction factor (C_f), which is the ratio between the rotameter reading ($Q_{rot.}$) divided by the actual volume flowrate ($Q_{act.}$), for each reading, and then finding the average value of the correction factor.

Draw the calibration curve, the reading of the rotameter (on y-axis) against the measured actual volume flowrate (on x-axis). Also, find the average correction factor from Fig. (2) shown below, by finding the slope of the line.

Discussion:

Discuss the relation between actual volume flow rate and rotameter reading. Also, compare between the average correction factor obtained from table and that obtain from the figure.

Objective: To Find Out the discharge of A Given Experiment

Out Come: Will Be Able to know How to Measure the discharge of a Give Experiment

VIVA QUESTIONS

1. What is meant by coefficient of discharge
2. Applications of rotometer
3. What are the advantages of rotometer
4. What are the forces acting on the float of the rotameter
5. What are the limitations of rotameter

10. CALIBRATION OF VIBRATION SETUP

Objective: To Find Out the vibration of A Given Experiment

Out Come: Will Be Able To know How to Measure the vibration of a Give Experiment

INTRODUCTION:

Mechanical vibration is something which, people usually like to avoid if they can except in some places where artificial vibration are purposely generated to speed up processes this mechanical vibration, if not within limits may cause damage to the materials, components or structure associated with it under some circumstance such as in transport, on machine floors where the vibration is inevitable, the components associated have withstand these vibrations. If such vibrations can be artificially generated on the components, their stability, reliability etc at the end of the test can be studied. One such device to generate artificial vibrations is called VIBRATION EXCITER or VBRATION GENERATOR.

The study and measurement of vibration in any structure or machine is of paramount importance for the following reasons:

1. Undesirable vibration is a waste of energy and causes wear and tear and subsequent breakdown resulting in high maintenance costs.
2. The noise produced due to vibrating bodies or structures cause human fatigue resulting in reduced efficiency.
3. Undamped vibration transmitted to structures (like bridges) might excite vibrations at natural frequency and cause permanent damage.

The instrument along with the above mentioned sensors can be employed for the following application:

1. Studying damping qualities of solids and road surface materials.
2. Monitoring vibrations on structures and machines.
3. Checking vibration severity on machines according to standards.
4. Used for institute balancing of rotors in machines.
5. Used with dampers to isolate vibrations of machines to their foundations and structures.

Specifications

Vibration exciter

- | | | |
|-------------------------------|---|-------------------|
| 1. Peak Sine force | : | 100 Newton's |
| 2. Peak velocity at resonance | : | 1 m/sec. 100m/sec |
| 3. Maximum displacement | : | 8mm peak to peak |
| 4. Power required | : | 200vA |
| 5. Weight | : | 30kg (normal). |

Power amplifier

- | | | |
|---------------------------|---|--------------------------|
| 1. Maximum output voltage | : | 20 V peak to peak |
| 2. Frequency response | : | 1Hz to within \pm 1KHz |
| 3. Harmonic distortion | : | less than 1% |

- | | | |
|---------------------|---|-------------------|
| 4. Input impedance | : | 10K Ohms (normal) |
| 5. Output impedance | : | 0.1 Ohms (normal) |
| 6. Gain at 1KHz | : | 20dB \pm 1dB |

Oscillator

- | | | |
|------------------------------|---|--------------------------------|
| 1. Output | : | Sinusoidal. |
| 2. Frequency range | : | 1Hz to 1KHz in 3 decade ranges |
| 3. Total Harmonic distortion | : | less than 1% |
| 4. Frequency indication | : | on a Analog panel meter |
| 5. Indication accuracy | : | \pm 2% of the range |
| 6. Frequency response | : | within \pm 1dB |

General

- | | | |
|-----------------------------|---|-----------------------------------|
| 1. Operating temperature | : | + 10°C to 45°C |
| 2. Power supply requirement | : | 230V, \pm 10% 50Hz single phase |
| 3. Power consumption | : | 300VA (normal) |

Vibration analyzer**Measuring functions and range:**

- | | | |
|---------------------|---|---|
| Displacement | : | 10 mm max |
| Velocity | : | 100mm/sec max |
| Acceleration | : | 1g max |
| Resolution | : | one part in 100 or better |
| Linearity | : | \pm 2% of full scale |
| Frequency response | : | 10Hz 2000Hz within 1dB while measuring velocity |
| D.C. output | : | 100mV(normal) full scale in velocity range. |
| Working temperature | : | \pm 10°C to \pm 50°C |
| Input A.C. mains | : | 230V 50Hz |
| Size | : | 300mm(W)*130mm(H)*340(D). |
| Weight | : | 5kgs |
| Number | : | single channel, mains operated |

Description

Vibration exciter is an electro dynamic type of device. It consists of a powerful magnet placed centrally surrounding which is suspended the exciter coil. This assembly is enclosed by high permeability magnetic circuit for optimum performance and enough design care has been observed to minimize the leakage magnetic flux at the top of the vibration table.

When an electrical current is passed through the exciter coil a magnetic field is created around the coil. This field interacts with the field due to the central permanent magnet and this result in the upward or downward movement of the suspended coil depending coil depending upon the direction of current flow in the coil. If an alternating current is injected into the coil, the coil moves up and down continuously. Thus controlling the frequency of the coil current of coil current, the frequency of vibration is controlled. By controlling the amount of the coil current, the amplitude of vibration is controlled.

Power oscillator model is the control unit for the exciter this unit consist of a tunable sine wave oscillator, a power amplifier to inject current into exciter coil.

A tunable sine wave oscillator is designed around a voltage controlled oscillator using an integrated circuit which develops triangular wave oscillations basically a special circuit called diode sine shapers is used to convert the triangular wave to sine wave suitable buffer amplifiers are incorporated to produce distortion less sine wave output with good amplitude stability and frequency response. The output is brought on to the front panel to feed into external circuit or to power amplifier input.

The power amplifier uses all silicon transistors circuitry for stable & trouble free operation. Adequate heat sinking is provided for the power transistors to operate at a comfortable running temperature even when the amplifier is delivering full power for an extended period of operation.

Elaborate, fast acting protection circuits are employed to render the amplifier almost foolproof. The output voltage is continuously monitored & when the level exceeds a preset limit, OVER VOLTAGE protection circuit operates cutting off the input to the amplifier. Similarly the output current (load current) is monitored and indicated on the panel ammeter in amperes when the preset safe limit is exceeded, 'OVER CURRENT' protection circuit outs off the amplifier input.

The temperature of the heat sink is sensed and when it raises beyond comfortable operating limit, OVER TEMPERATURE protection circuit functions to switch off the input to amplifier. Thus the power oscillator is designed with almost care to render better and trouble free service to the user.

Controls of vibrations analyzer:

- | | | |
|-----------------------|---|---|
| 1. POWER ON | : | Racher switch |
| Position ON | : | Red light glows. |
| Position OFF | : | instrument is switched OFF |
| 2. SELECTOR SWITCH | : | 4 pole 3 way switch is to select the vibration Parameters |
| Position DISPLACEMENT | : | Instrument indicates displacement of vibration |
| Position VELOCITY | : | Instrument indicates velocity of vibration |
| Position ACCELERATION | : | Instrument indicates acceleration of vibration |

3. SENSOR : Vibration sensor is plugged to this socket. A 3pin socket is to interconnect the vibration pickup and vibration analyzer
4. ANALOG METER : It is to measure the output of vibration parameters
5. FUSE : 500mA 250V slow blow fuse in the rear panel of the instrument

Controls of oscillator & power amplifier

1. POWER ON : A DPDT switch is to supply the power from mains to instrument.
2. FREQUENCY COARSE : 4 pole 3 way switch is provided to select the required range of frequency i.e., 10/100 & 1000Hz
 - : 1Hz to 10Hz range
 - : 1Hz to 100Hz range
 - : 1Hz to 1000Hz range
3. FREQUENCY FINE : 10K 10 turn pot is to adjust the required frequency i.e., 0-10, 0-100 and 0-1000Hz.
4. OUTPUT : 2 nos. of PT 10 connections is to interconnect the power amplifier to vibration generator (red and green)
5. ANALOG METERS : 2nos. of analog meter is to measure amplitude and frequency.

Operation:

MOUNTING VIBRATION SENSOR

Whenever accurate measurement or continuous monitoring is required, the vibration sensor should be mounted such that the axis of the sensor is perpendicular to the direction of vibrating surface.

Whenever fast measurements and vibrations on remote points are required the sensor can be used with extension probe and should be held gently perpendicular to the direction of vibrating surface.

MEASUREMENT

Connect the vibration sensor and indicator by means of the connecting cable provided to INPUT socket. The instrument indicates velocity or displacement or frequency of vibration depending on the function switch position. The range switch indicates full scale deflection range of the parameter selected. The multiplier mentioned on the panel meter should multiply the readings.

RECORDING VIBRATIONS:

The velocity of vibration can be recorded on an oscillograph between AC output terminals. If a visual observation is required on oscilloscope scope can be connected between the same terminals. 200mV RMS signal is available for full scale deflection on velocity range.

If a D.C. recorder is available or continuous monitoring of vibration level is required the same can be connected between D.C. output terminals D.C. voltage is available in velocity and displacement positions A 100mV D.C. signal is available for full scale deflection of meter.

OPERATING PROCEDURE:

1. Connect the generator cable to power amplifier output connectors (i.e., red & green).
2. Fix the vibration pickup (i.e., piezo electric sensor) on vibrator generator shaft.
3. Keep the amplitude pot at minimum position.
4. Connect the 3 pin power cable, i.e., both power amplifier & vibration analyzer to 230V / 50Hz AC mains.
5. Connect the vibration pickup cable (red) to vibration analyzer.
6. Switch on the power on switch of both.
7. Slowly rotate the amplitude pot in clockwise direction. So the both analog meter will start show the readings.
8. First select the frequency selector switch to 100 range so that generator will start vibrating depending upon frequency and amplitude.
9. Keep amplitude constant & select the frequency from 50Hz then observe the reading of vibration parameter in vibration analyzer display (analog).
10. Observe different reading for different frequencies.
11. Before switch off the power amplifier, please keep the amplitude pot at minimum position.

DRAWINGS

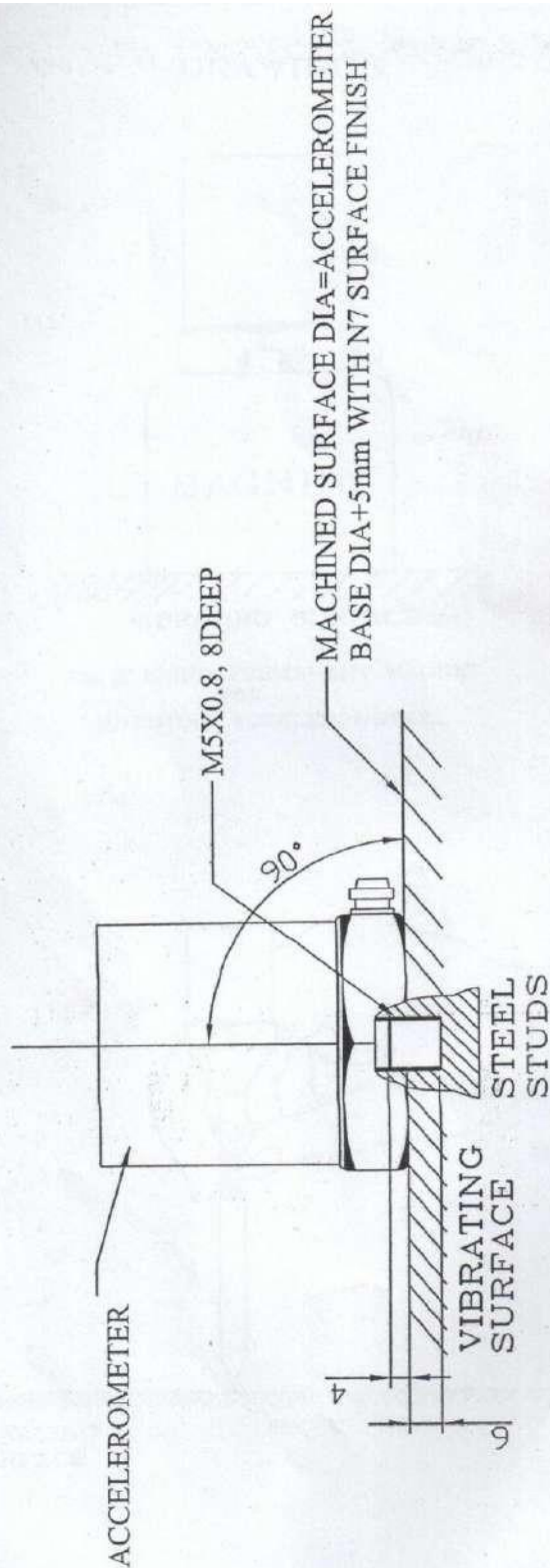

Fig.1 ACCELEROMETER MOUNTED
RIGIDLY ON
VIBRATING SURFACE

ALL DIMENSIONS ARE IN mm

LOG SHEET

Sl.no	REMARKS

VIVA QUESTIONS

1. What do you mean by vibration?
2. What is a seismic wave.
3. What are the advantages of piezoelectric transducer?
4. What is frequency?
5. What are the units for frequency?

11. CALIBRATION OF McLeod GAUGE

Objective: To Find Out the vacuum of A Given Experiment

Out Come: Will Be Able to Analyze How to Measure the vacuum error of a Give Experiment

Object : To calibrate the given vacuum cell. (Low Pressure Cell)

Apparatus : Vacuum Cell, Dial type Vacuum gauge Vacuum Chamber, Vacuum pump to develop vacuum and digital vacuum indicator.

Theory : In everyday usage, vacuum is a volume of space that is essentially empty of matter, such that its gaseous pressure is much less than atmospheric pressure. The word comes from the Latin for “empty”. A perfect vacuum would be one with no particles in it at all, which is impossible to achieve in practice. Physicists often discuss ideal test results that would occur in a perfect vacuum, which they simply call “vacuum” or “free space”, and use the term partial vacuum to refer to real vacuum. The Latin term in vacuum is also used to describe an object as being in what would otherwise be a vacuum.

Vacuum is useful in a variety of processes and devices. Its first widespread use was in the incandescent light bulb to protect the filament from chemical degradation. The chemical inertness produced by a vacuum is also useful for electron beam welding, cold welding, vacuum packing and vacuum frying. Ultra-high vacuum is used in the study of atomically clean substrates, as only a very good vacuum preserves atomic-scale clean surfaces for a reasonably long time (on the order of minutes to days). High to ultra-high vacuum removes the obstruction of air, allowing particle beams to deposit or remove materials without contamination. This is the principle behind chemical vapor deposition, physical vapor deposition, and dry etching which are essential to the fabrication of semi conductors and optical coatings, and to surface science. The reduction of convection provides the thermal insulation of thermos bottles. Deep vacuum lowers the boiling point of liquids and promotes low temperature out gassing which is used in freeze drying, adhesive preparation, distillation, metallurgy, and process purging. The electrical properties of vacuum make electron microscopes and vacuum tubes possible, including cathode ray tubes. The elimination of air friction is useful for flywheel energy storage and ultracentrifuges.

DIGITAL VACUUM INDICATOR:

Vacuum indicator comprises of inbuilt power supply which provides power for strain gauge excitation, signal conditioning and amplifying circuits. Access input from the strain gauges linearizes and amplifies the signal level. The output of the amplifier is controlled to required level and calibrated to read the vacuum in mm/in.Hg. Any stray forces on the sensor can be balanced by balancing the strain gauge bridge through potentiometer, which is provided in the front panel. This system operates by 230v Ac supply.

PANEL DETAILS:

POWER ON: Rocker switch which switches on the supply of the instrument, with red light indication.

ZERO: Ten turn potentiometer. The display can be adjusted to read Zero when no force is applied.

CAL: Single turn potentiometer. The output of the amplifier is adjusted by this potentiometer such that the display gives full scale for given range of sensor.

TO SENSOR: Sensor is connected to the indicator through a four core cable with 5 pin socket at sensor end ends and respective color connections at the other end to connect the instrument.

MAINS INPUT: Power cable. Power cable to be connected to the mains supply of 230V 50Hz.

FUSE: 500 mA cartridge fuse with holder located on the rear side of the instrument to protect the instrument from internal electrical shorting.

CAUTION: Do not remove the fuse cap with power cable plugged to the mains supply.

PROCEDURE:

Connect the vacuum cell to the vacuum indicator through given cable.

Connect the instrument to mains i.e. 230V power supply and switch on the instrument.

Adjust the zero pot on the indicator, to indicate zero.

Connect the vacuum pump to 230V AC mains.

Close the outlet valve of the vacuum chamber and open the inlet valve.

Switch on the pump.

Wait until vacuum reaches maximum level.

Now read the vacuum gauge reading and adjust the CAL pot of the digital indicator to same vacuum. Now the given vacuum cell is calibrated.

Close the inlet valve and switch of the vacuum pump.

Now solely open the outlet valve and down the reading of dial gauge and digital indicator.

Calculate the error if any and plot the graph of dial gauge reading v/s Digital reading.

TABULAR COLUMN:

Sl. no	Vacuum in Dial gauge in.Hg	Vacuum in Digital Indicator, in.Hg	Correction	Error	% Error *100

VIVA QUESTIONS

1. what is the use of pressure gauge?
2. what is angularity error?
3. what are the advantages of pressure gauge?
4. what are the disadvantages of pressure gauge?
5. what are the limitation of pressure gauge?
6. what are the zero order error? 7. what are the multiplication of error ?

VIVA QUESTIONS

1. what is the use of pressure gauge?
2. what is angularity error?
3. what are the advantages of pressure gauge?
4. what are the disadvantages of pressure gauge?
5. what are the limitation of pressure gauge?
6. what are the zero order error?
7. what are the multiplication of error ?
8. Define transducer?
9. What is the pressure transducer?
10. Give commonly used pressure sensitive devices?
11. What do you meant by transducer?
12. What is LVDT?
13. Explain the operation of LVDT.
14. Rate at which angular displacement changes with time is called angular velocity
15. In system international, angular velocity is measured in radians per second
16. Revolution per minute is system international unit of the angular velocity
17. What is accuracy
18. What is precision
19. Expand LVDT
20. What is the applications of pyrometer
21. List the applications of pressure guages
22. How are thermocouples different from thermistors
23. classify the different tachometers
24. Name a few sources of errors
25. What is hysteresis

12. Measurement And Control Of Temperature Of A Process Using Resistance Temperature Detector With SCADA

Objective: To Find out the Temperature using SCADA software of A Given Experiment

Out Come: Will Be Able to Analyze How to Measure the Temperature using the SCADA of a Give Experiment

1. Introduction:

Proportional, Integral, and Derivative controller or PID is a standard feedback loop component in industrial control applications. It measures an "output" of a process and controls an "input", with a goal of maintaining the output at a target value, which is called the "setpoint". An example of a PID application is the control of a process temperature, although it can be used to control any measurable variable which can be affected by manipulating some other process variable.

The Controller compares a measured value from a process (typically and industrial process) are as follows

Industrial processes are procedures involving chemical or mechanical steps to aid in the manufacture of an item or items, usually carried out on a large scale.

Industrial processes are the key components of heavy industry.

Most processes make the production of an otherwise rare material vastly cheaper, thus changing it into a commodity; i.e. the process makes it economically feasible for society to use the material on a large scale. One of the best examples of this is the change in aluminum from prices more expensive than silver to its use in recyclable/disposable beverage containers.

The difference (or "error" signal) is then used to calculate a new value for a manipulatable input to the process that brings the process' measured value back to its desired setpoint. Unlike simpler control algorithm, the PID controller can adjust process outputs based on the history and rate of change of the error signal, which gives more accurate and stable control. (It can be shown mathematically that a PID loop will produce accurate, stable control in cases where a simple proportional control would either have a steady state error or would cause the process to oscillates). PID controllers do not require advanced mathematics to design and can be easily adjusted (or "tuned") to the desired application, unlike more complicated control algorithms based on optimal control theory.

2. Theory:

PROPORTONAL BAND

The control algorithm that generates a linear control output proportional to deviation is called proportional action. In proportional action the amount of change in the measured value (or deviation) is expressed in percent of span that is required to cause the control output to change from 0 to 100% is called the proportional band.

$$P = K_p [SP - PV] + P_0$$

INTEGRAL TIME

With P action the measured valve will not necessarily become equal to the set the point, and a deviation will usually be present. The control algorithm that applies changes in output as long as a deviation exists, so as to bring the deviation to zero, is called integral action.

When integral action is used, the parameter that determines how fast the output will change in correspondence to some amount of deviation is referred to as integral time, and shorter the integral time, stronger the integral action (the greater the output rate of change). I action is usually used together with P action as PI action, and due only to I became equal to that due only to P action.

$$P = 1/T_i [SP - PV] + P_0$$

DERIVATIVE TIME:

If the controlled object has a large time constant or dead time, with P or PI action alone there will be cases where the response will be slow, overshoot will occur, and the control system will be unstable. In order to achieve faster response and more stable operation cases one uses derivation action (D action) to apply an output component proportional to the input (deviation) rate of change.

D action must always be used with P action time required with PD action. If a ramp input (constant rate of change input) is applied, for the output due to P action alone to become equal to that due to D action alone. The longer the derivation time, the stronger the derivation action.

$$P = T_d \frac{d}{dt} [SP - PV] + P_0$$

SPECIFICATIONS:

S.NO	Particulars	Specification
01	Heater / Boiler	3KW
02	Rotameter	100-200 LPH
03	Thyristor Drive	I/P (0-5V) DC O/P (0-230V) Capacity:3KW
04	SS Source Tank	l=250;b=250;h=250
05	Motor	Drive 55W RPM 6000 Operating at 230V AC/DC

06	Temperature Sensor	RTD-(PTD 100)
07	Interface Card	12-Bit Data Acquisition card with DAQ o/p (0-5V) through Rs-232 Serial comm. port to PC
08	Controller	PC Based PID Controller developed using LAB VIEW Software.

SYSTEM CONFIGURATION

1. System Overview:

The Temperature process controller can be individually classified under four heads namely

- a. The System Overview
- b. The PID controller
- c. Process control Software

The System Overview:

The Overall system is a metallic structure, and it accommodates the multi-output DC power supply, (RTD) temperature transmitter, measuring instruments and inlet sockets for AC main.

PID CONTROLLER:

When all three control effects proportional, integral and derivative are combines together, we obtain the benefits of each control action. A three mode controller contains the “Stability” of proportional control and the “ability” to provide an immediate correction for the Magnitude of a disturbance because of rate control. In this trainer computer (PC) acts a PID controller. PID controller is comprised of two units, namely.

- a) PC based PID controller software.
- b) Temperature Loop controller Trainer.

PROCESS CONTROL SOFTWARE:

Process control software is indigenous software designed using the LABVIEW software for the temperature

process. The software package for temperature control application is very simple and powerful, general purpose which measures the process variable, displays it on the screen.

The software is organized to explain all the control action available for the ON/OFF control, proportional control (P), proportional plus integral control (PI), proportional plus derivative control (PD) and proportional plus integral plus derivative control (P+I+D).

Note:

Temperature process is generally a very slow process compared to other process. Usually proportional integral and derivative control is preferred for temperature control.

Some of the key features of the software are,

1. User feedable process parameter
2. Facility to store the data being processed as a separate file on the disk which can be used for future analysis.
3. A complete display of the process
4. Display all the graphical parameters both numerically and graphically.
5. Simultaneous graphical display the process variable.
6. Analyze the stored data.
7. Tune the control parameter for PID
8. To perform a historical trend of the process.

2. Overall Panel Block Diagram:

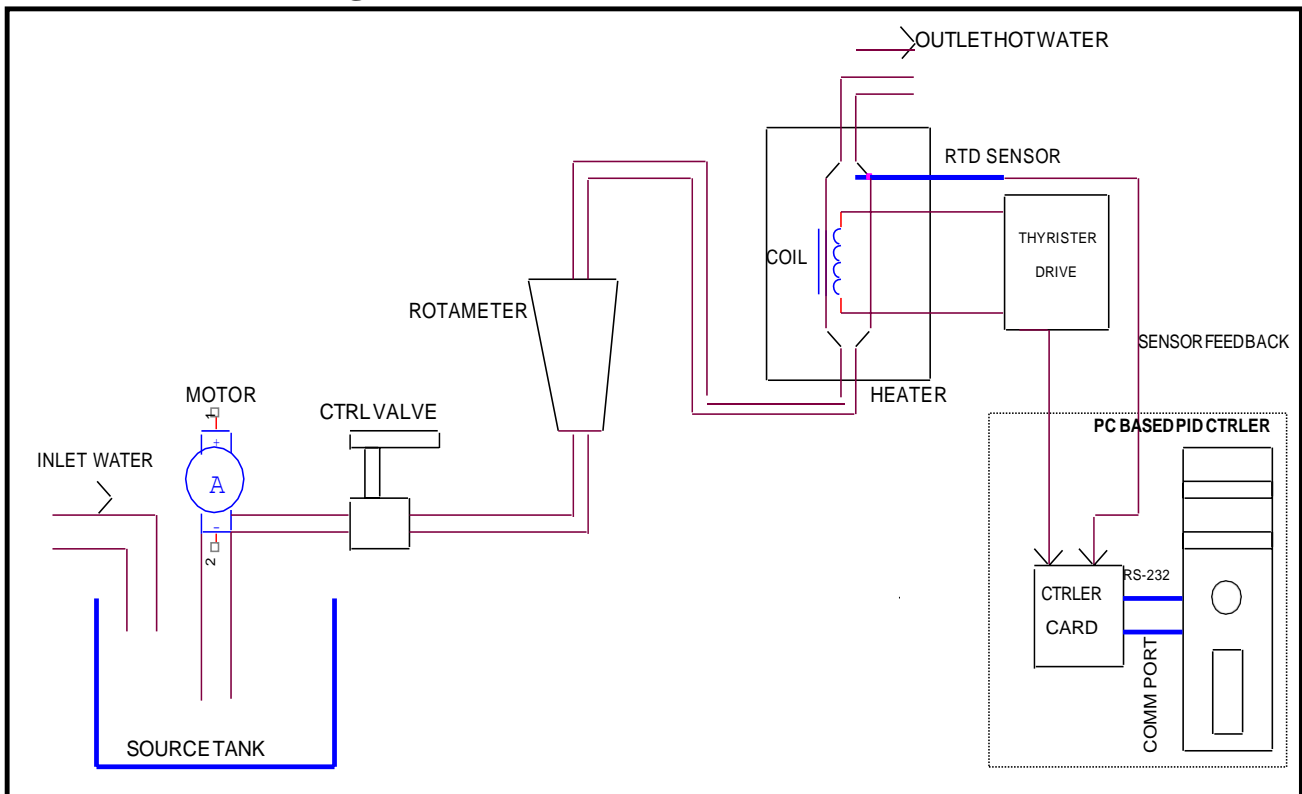

Electrical Connection for Temperature Loop Controller-PID

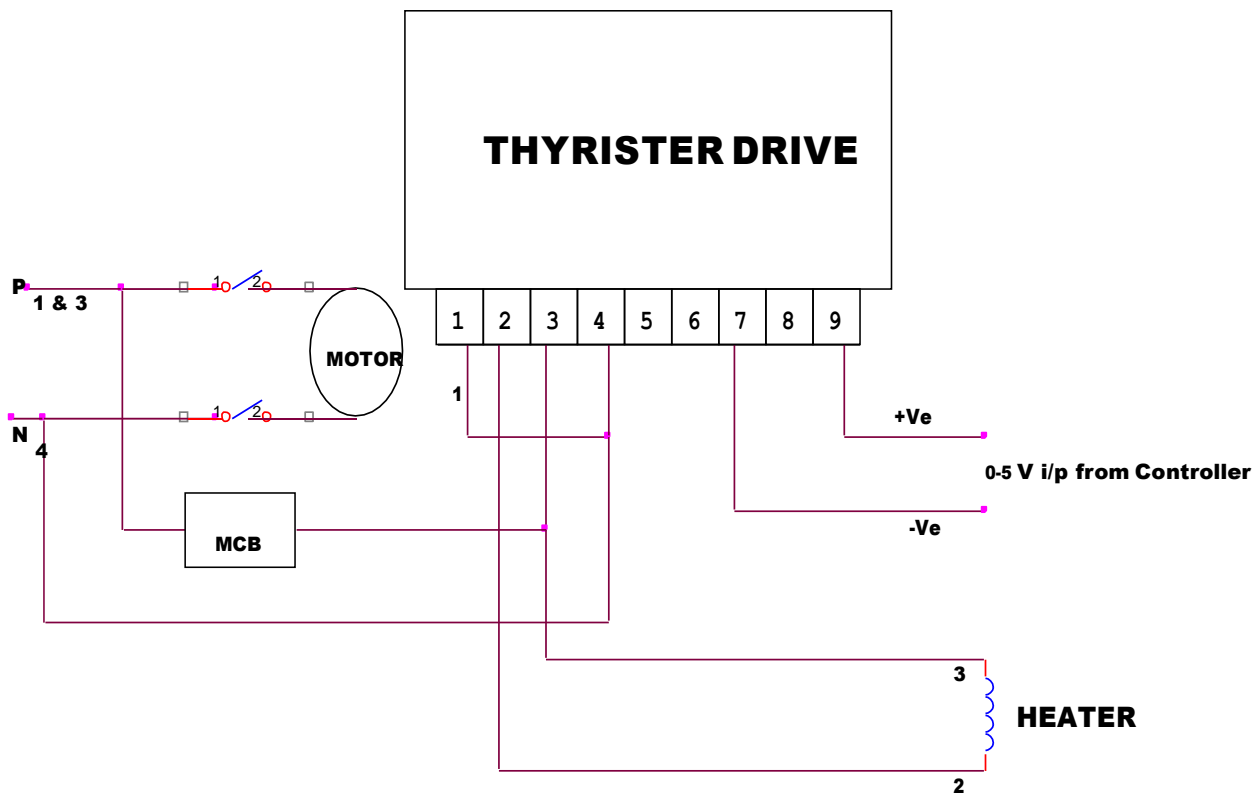

3.

SYSTEM OPERATION

1. Operating Procedure:

Primary Connection:

1. Connect the power supply 230V / 15A using power socket.
2. Connect the Thyristor i/p to the interface unit.
3. Connect the interface unit to RS-232 comm. port to PC.
4. Fill the source tank up to 3/4th of the capacity.
5. Source out the water line to outside to the sink.

For Water Circulation:

1. Switch ON the motor.
2. Open the control valve, so that water starts flowing through Rotameter and pump and out through the Heater/Boiler from the hot water pipe.
3. Maintain the flow rate at min (30/60lits)/hr in LPH, Ensure that the same amount of cold water is coming into the tank.

For Communication to PC:

1. Switch ON the MCB.
2. Switch ON the power supply of interface card.

- From the interface card connect the RS-232 comm. port to the PC serial port (com1 or com2).

WARNING!

The inlet cold water and outlet hot water flow rate should be matched other wise water in the tank might get over filled (or) empty; it damages the pump and also the heater.

CONNECTION DETAILS:

1. ELECTRICAL CONNECTION DETAILS:

- Connect the Power supply to the system using 3-Pin cable provided; Ensure that the power of 3KW is available.
- Connect the power supply to the signal conditioner and Controller instrument through the 3-PIN cable provided.
- Connect the 5V controller I/P from the controller instrument to the Thyrister Drive, ensure the polarity is properly matched.

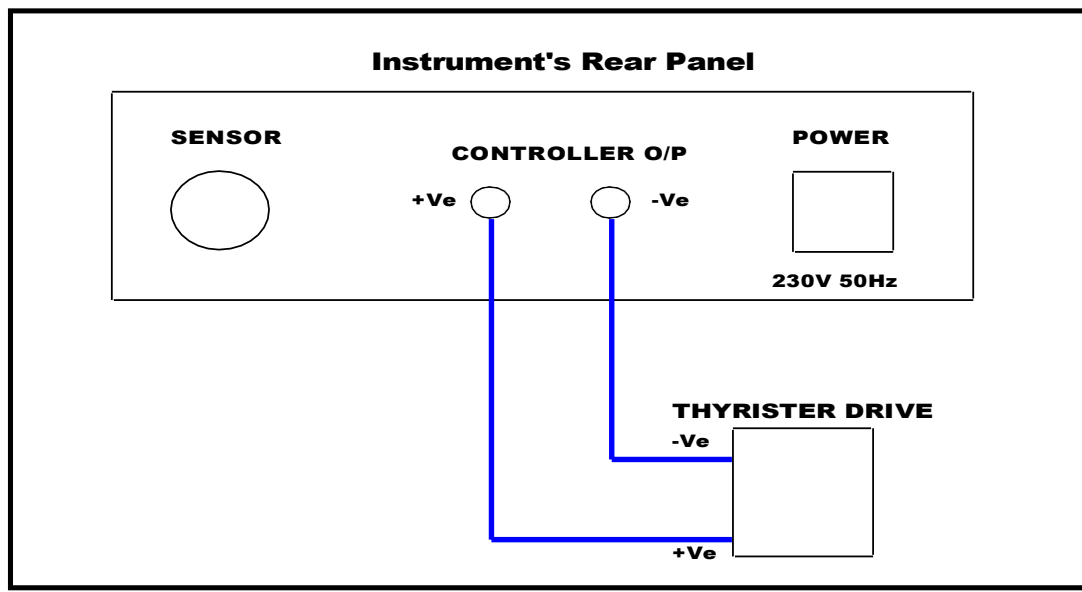

- Connect the RTD sensor to the back panel of the controller through the cable provided.

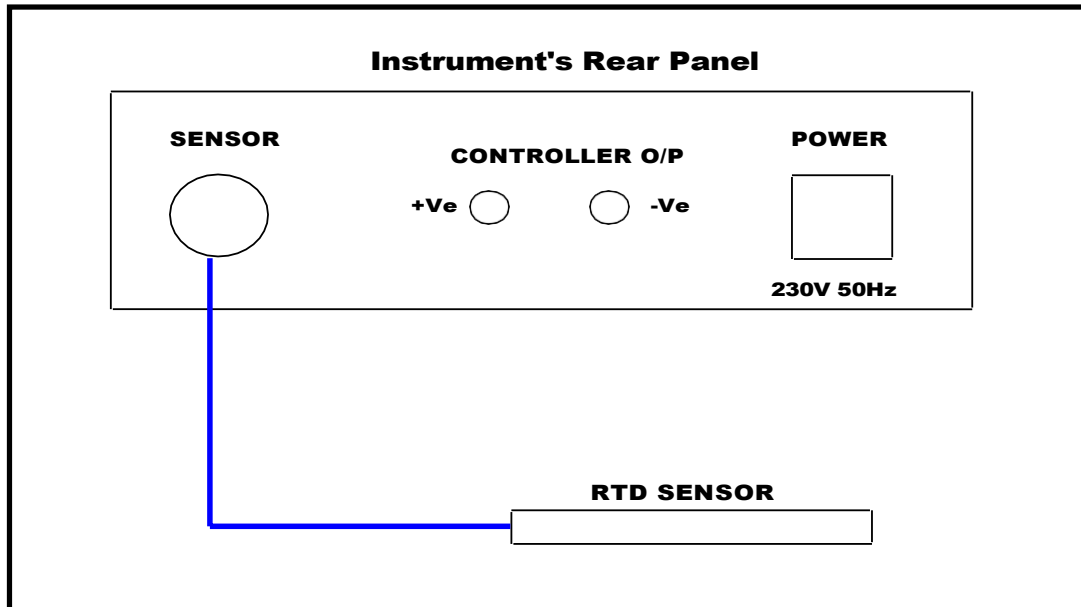

2. MECHANICAL CONNECTION DETAILS:

- Connect the input water to the Source Water Tank, ensure that the water should continuously available for the throughout the experiment.

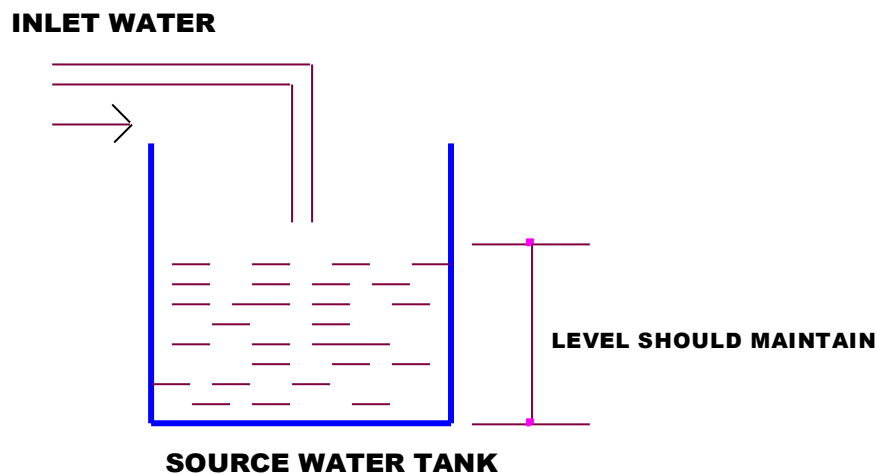

- Hot water outlet from the boiler should be drained outside.

3. PROCEDURE FOR MAINTAINING THE CONSTANT FLOW RATE:

- Switch ON the motor.
- Open the control valve so that the Rota meter shows the flow rate between 30 to 60 LPM.
- Adjust the inlet water to the SS Tank so that the intake of the water is approximately equal to the Outlet water (HOT WATER). So that the level of water in the SS tank is maintained.

EXPERIMENT SECTION FOR TEMPERATURE LOOP CONTROLLER:

EXPERIMENT-1:**STUDY OF PROPORTIONAL CONTROL USING PROCESS CONTROL SOFTWARE:****Aim:**

To study the action “**PROPORTIONAL CONTROL**” control for a Temperature process controller using process control software.

Theory:

The team ultimate was attached to this method because its use requires the determination of the ultimate proportional band and ultimate period. The Ultimate proportional band, P_u is the minimum allowable value of proportional band (for a controller with only proportional mode) for which the system continuously oscillating at constant amplitude. The ultimate period (T_u) is the period of response with the proportional band set to its ultimate value. To determine the ultimate proportional band and ultimate period the proportional band of the controller (with all integral and derivative action turned off) is gradually reduced until the process cycles continuously.

Experiment steps:

1. Check all the connections for the instrument.
2. Ensure the sufficient water level in the tank, and maintain the level as explained above (in Procedure)
3. Switch ON the Temperature Loop Trainer Instrument.
4. Switch On the Thyristor Drive.
5. Start PID CONTROLLER software in the PC.
6. Select online when prompted and then enter the file name for which the Datas to be stored.
7. And then click the CONTINUE TEST button option in the Tool bar of the PID Software.
8. The Controller starts data-logging automatically and starts controlling process based on the preset P,I,D Values.

For ‘P’ (Proportional Control):-

For controlling the ‘P’ Value, keep the ‘I’ and ‘D’ value ‘0’ (zero).

EXPERIMENT-2:**STUDY OF P+I CONTROL USING PROCESS CONTROL SOFTWARE:****Aim:**

To study the action “**PROPORTIONAL PLUS INTEGRAL CONTROL**” control for a Temperature process controller using process control software.

Theory:

The team ultimate was attached to this method because its use requires the determination of the ultimate proportional band and ultimate period. The Ultimate proportional band, P_{BU} is the minimum allowable value of proportional band (for a controller with only proportional mode) for which the system continuously oscillating at constant amplitude. The ultimate period (T_u) is the period of response with the proportional band set to its ultimate value. To determine the ultimate proportional band and ultimate period the proportional band of the controller (with all integral and derivative action turned off) is gradually reduced until the process cycles continuously.

Experiment steps:

1. Check all the connections for the instrument.
2. Ensure the water level in the tank.
3. Start the Temperature Loop Trainer Instrument.
4. Switch On the Motor.
5. Adjust the FLOW RATE at 30-60 lit/hr.
6. Switch On the Thyristor Drive.
7. Start PID CONTROLLER software in the PC.
8. Select online prompted and then enter the file name for which the Datas to be stored.
9. And then click the CONTINUE TEST option in the Tool bar of the PID Software.
10. The Controller starts data-logging automatically and starts controlling process based on the preset P,I,D Values.

For ‘PI’ Control:

For controlling the ‘PI’ value, keep the ‘D’ value as ‘0’ (zero)

EXPERIMENT-3:**STUDY OF P+D CONTROL USING PROCESS CONTROL SOFTWARE:****Aim:**

To study the action “**PROPORTIONAL PLUS DERIVATIVE CONTROL**” control for a Temperature process controller using process control software.

Theory:

The team ultimate was attached to this method because its use requires the determination of the ultimate proportional band and ultimate period. The Ultimate proportional band, P_u is the minimum allowable value of proportional band (for a controller with only proportional mode) for which the system continuously oscillating at constant amplitude. The ultimate period (T_u) is the period of response with the proportional band set to its ultimate value. To determine the ultimate proportional band and ultimate period the proportional band of the controller (with all integral and derivative action turned off) is gradually reduced until the process cycles continuously.

Experiment steps:

1. Check all the connections for the instrument.
2. Ensure the water level in the tank.
3. Start the Temperature Loop Trainer Instrument.
4. Switch On the Motor
5. Adjust the FLOW RATE at 30-60 lit/hr
6. Switch On the Thyristor Drive.
7. Start PID CONTROLLER software in the PC.
8. Select online prompted and then enter the file name for which the Datas to be stored.
9. And then click the CONTINUE TEST option in the Tool bar of the PID Software.
10. The Controller starts data-logging automatically and starts controlling process based on the preset P,I,D Values.

For ‘P+D’ Control:

For controlling the ‘PD’ value, keep the ‘I’ value as ‘0’ (zero)

EXPERIMENT-4:

STUDY OF P+I+D CONTROL USING PROCESS CONTROL SOFTWARE:**Aim:**

To study the action “**PROPORTIONAL PLUS INTEGRAL PLUS DERIVATIVE CONTROL**” control for a Temperature process controller using process control software.

Theory:

The team ultimate was attached to this method because its use requires the determination of the ultimate proportional band and ultimate period. The Ultimate proportional band, P_{BU} is the minimum allowable value of proportional band (for a controller with only proportional mode) for which the system continuously oscillating at constant amplitude. The ultimate period (T_u) is the period of response with the proportional band set to its ultimate value. To determine the ultimate proportional band and ultimate period the proportional band of the controller (with all integral and derivative action turned off) is gradually reduced until the process cycles continuously.

Experiment steps:

1. Check all the connections for the instrument.
2. Ensure the water level in the tank.
3. Start the Temperature Loop Trainer Instrument.
4. Switch On the Motor
5. Adjust the FLOW RATE at 30-60 lit/hr
6. Switch On the Thyristor Drive.
7. Start PID CONTROLLER software in the PC.
8. Select online prompted and then enter the file name for which the Datas to be stored.
9. And then click the CONTINUE TEST option in the Tool bar of the PID Software.
10. The Controller starts data-logging automatically and starts controlling process based on the preset P,I,D Values.

For ‘PID’ control:

For controlling the ‘PID’ value, SET all the values.

Ultimate (Ziegler and Nicholas) method)**Theory:**

The team ultimate was attached to this method because its use requires the determination of the ultimate proportional band and ultimate period. The Ultimate proportional band, P_{BU} is the minimum allowable value of proportional band (for a controller with only proportional mode) for which the system continuously oscillating at constant amplitude. The ultimate period (T_u) is the period of response with the proportional band set to its ultimate value. To determine the ultimate proportional band and ultimate period the proportional band of the controller (with all integral and derivative action turned off) is gradually reduced until the process cycles continuously.

Experiment steps:

- Start the Temperature Loop Trainer Instrument.

- Switch On the Motor
- Adjust the FLOW RATE at 30-60 lit/hr
- Switch On the Thyristor Drive.
- Start PID CONTROLLER software in the PC.
- Select online prompted and then enter the file name for which the Datas to be stored.
- And then click the CINTINUE TEST in the Tool bar of the PID software.
- The Controller starts data-logging automatically and starts controlling process based on the preset P,I,D Values.

a. For 'P' Control:

For controlling the 'P' Value, keep the 'I' and 'D' value '0' (zero).

b. For 'PI' Control:

For controlling the 'PI' value, keep the 'D' value as '0' (zero)

c. For 'PID' control:

For controlling the 'PID' value, SET all the values.

Note: Keep the 'P' value approx around	100 to 150
Keep the 'I' value approx around	1
Keep the 'D' value approx around	0.2

Tuning of Controller:

1. Give a step change approx (10%) to the set value and absorb the process response.
2. If the system is over damped reduce the proportional band.
3. If the system is under damped increase the proportional band.
4. Note the proportional band at which the process response just starts continuously cycling with constant amplitude.
period required for one cycle.

By Ziegler Nicholas method:

Mode	Proportional	Integral	Derivation
P	2PBu		
P+I	2.2PBu	Tu/1.2	
P+D	1.65PBu		Tu / 8.0
P+I+D	1.65 PBu	0.5 Tu	Tu / 8.0

Select mode to study and use PID valves from above

BILL OF MATERIALS FOR TEMPERATURE LOOP CONTROL TRAINER:

1. Loop control stand.
2. S.S tank 250x250x300
3. Heater
4. Rotameter 300 LPH.
5. Pump 350 LPH
6. Thyristor Drive
7. Brass control valve (1/2")
8. Brass Control valve (1/4")
9. Brass Nipple (1/2")
10. S.S Bend (1/2")
11. Adapter (1/2").
12. Tube clamp
13. M.C.B (16Amps)
14. Toggle Switch.
15. Power supply cover.
16. Spring sleeve.
17. Power supply cable.
18. 'L' bend.
19. Thyristor Drive cover
20. Three pin Industrial plug (16Amps)
21. Water tube.
22. Hot water tube.
23. RTD sensor
24. Stand Legs
25. PID Controller software CD.
26. Signal conditioner interface connector.

Experiment 13

13. Measurement And Control Of Flow Of A Process Using SCADA Systems

1. Introduction:

FLOW MEASUREMENT SYSTEM is basically a closed loop system having Orifice with DPT setup to measure the flow rate in LPH used as Feed back to control the flow rate. The system is self-contained with a water tank and Orifice with DPT fitted on the panel. The sensors are connected with ½” piping. A FHP monoblock pump is fitted to circulate the water. Controlling of flow is made through control valve fitted. The whole system is housed on a table top powder coated metal box.

Proportional, Integral, and Derivative controller or PID is a standard feedback loop component in industrial control applications. It measures an "output" of a process and controls an "input", with a goal of maintaining the output at a target value, which is called the "set point". An example of a PID application is the control of a process temperature, although it can be used to control any measurable variable which can be affected by manipulating some other process variable.

The Controller compares a measured value from a process (typically any industrial process) is as follows

Industrial processes are procedures involving chemical or mechanical steps to aid in the manufacture of an item or items, usually carried out on a large scale.

Industrial processes are the key components of heavy industry.

Most processes make the production of an otherwise rare material vastly cheaper, thus changing it into a commodity; i.e. the process makes it economically feasible for society to use the material on a large scale. One of the best examples of this is the change in aluminum from prices more expensive than silver to its use in recyclable/disposable beverage containers.

Theory:**PROPORTIONAL BAND**

The control algorithm that generates a linear control output proportional to deviation is called proportional action. In proportional action the amount of change in the measured value (or deviation) is expressed in percent of span that is required to cause the control output to change from 0 to 100% is called the proportional band.

$$P = K_p [SP - PV] + P_0$$

INTEGRAL TIME

With P action the measured value will not necessarily become equal to the set point, and a deviation will usually be present. The control algorithm that applies changes in output as long as a deviation exists, so as to bring the deviation to zero, is called integral action.

When integral action is used, the parameter that determines how fast the output will change in correspondence to some amount of deviation is referred to as integral time, and shorter the integral time, stronger the integral action (the greater the output rate of change). I action is usually used together with P action as PI action, and due only to I became equal to that due only to P action.

$$P = I/T_i [SP - PV] + P_0$$

DERIVATIVE TIME:

If the controlled object has a large time constant or dead time, with P or PI action alone there will be cases where the response will be slow, overshoot will occur, and the control system will be unstable. In order to achieve faster response and more stable operation cases one uses derivation action (D action) to apply an output component proportional to the input (deviation) rate of change.

D action must always be used with P action time required with PD action. If a ramp input (constant rate of change input) is applied, for the output due to P action alone to become equal to that due to D action alone. The longer the derivation time, the stronger the derivation action.

$$P = T_d \frac{d}{dt} [SP - PV] + P_o$$

SPECIFICATIONS

FLOW METER	: Orifice with DP Sensor
RANGE	: 300LPH.
PUMP	: FHP monoblock pump
SENSOR	: Orifice plate with DPT
SENSOR O/P	: 4-20mA
CONTROL VALVE	: ½” Glove Valve (Linear) 15mm stem Travel.
ACTUATOR	: Pneumatic Actuator (input 3-15 PSI)
I to P	: Input 4-20mA output 3-15PSI
DATA LOGGER	: 16 bit ADC 8 Channel with 12 Bit DAC interfaced with PC through RS-232 Serial port.
CONTROLLER OUTPUT	: 4 – 20mA
POWER	: 230V 50Hz. Power supply to drive the monoblock pump.

NOTE: Customer has to provide necessary Air Supply through a Compressor at 6 to 8Kg/cm² Pressure. Water supply needed to run the process should be provided.

SYSTEM CONFIGURATION

1. System Overview:

The Flow Loop Trainer controller can be individually classified under two heads namely

- d. The System Overview
- e. Process control Software

A The System Overview:

The Overall system is a metallic structure, and it accommodates the, Orifice Plate with DP Transmitter to measure the Flow Rate. SS Source tank is fitted to store the water. To circulate the water ½ HP mono blocks Pump is used. Control Valve with Pneumatic Actuator is used to control the flow rate. The Pneumatic Actuator is controlled through I to P converter which gives out 3 to 15 PSI pressure required to open and close the control valve by accepting 4 to 20mA as input from a PID controller. The whole system is a Table top model which occupies very less place in the Laboratory with all industrial grade materials fitted on a Powder Coated Metal Frame.

B. PROCESS CONTROL SOFTWARE:

Process control software is indigenous software designed using the LABVIEW software for the Flow process. The software package for Flow control application is very simple and powerful, general purpose which measures the process variable, displays it on the screen.

The software is organized to explain all the control action available for the ON/OFF control, proportional control (P), proportional plus integral control (PI), proportional plus derivative control (PD) and proportional plus integral plus derivative control (P+I+D).

Some of the key features of the software are,

9. User feedable process parameter
10. Facility to store the data being processed as a separate file on the disk which can be used for future analysis.
11. A complete display of the process
12. Display all the graphical parameters both numerically and graphically.
13. Simultaneous graphical display the process variable.
14. Analyze the stored data.
15. Tune the control parameter for PID
16. To perform a historical trend of the process.

EXPERIMENT SECTION FOR FLOW LOOP CONTROLLER:**EXPERIMENT-1:****STUDY OF PROPORTIONAL CONTROL USING PROCESS CONTROL SOFTWARE:****Aim:**

To study the action “**PROPORTIONAL CONTROL**” control for a Flow process controller using process control software.

Theory:

The team ultimate was attached to this method because its use requires the determination of the ultimate proportional band and ultimate period. The Ultimate proportional band, P_{BU} is the minimum allowable value of proportional band (for a controller with only proportional mode) for which the system continuously oscillating at constant amplitude. The ultimate period (T_u) is the period of response with the proportional band set to its ultimate value. To determine the ultimate proportional band and ultimate period the proportional band of the controller (with all integral and derivative action turned off) is gradually reduced until the process cycles continuously.

Experiment steps:

9. Check all the connections for the instrument.
10. Ensure that the water is adequate in the Source tank for experimentation.
11. Ensure that the Bypass Valve is not in closed position.
12. Switch on the Flow loop instrument.
13. Start PID control software in the PC.
14. Enter the Name, Batch and Press ‘Start Test’ button.
15. Select Set point type as Manual and then click the ‘RECORD’ button option.
16. The Controller starts data-logging automatically and starts controlling process based on the preset P, I, D Values.

For ‘P’ (Proportional Control):-

For controlling the ‘P’ Value, keep the ‘I’ and ‘D’ value ‘0’ (zero).

**EXPERIMEN
T-2:**

STUDY OF P+I CONTROL USING PROCESS CONTROL SOFTWARE:**Aim:**

To study the action “**PROPORTIONAL PLUS INTEGRAL CONTROL**” control for a Temperature process controller using process control software.

Theory:

The team ultimate was attached to this method because its use requires the determination of the ultimate proportional band and ultimate period. The Ultimate proportional band, P_{BU} is the minimum allowable value of proportional band (for a controller with only proportional mode) for which the system continuously oscillating at constant amplitude. The ultimate period (T_u) is the period of response with the proportional band set to its ultimate value. To determine the ultimate proportional band and ultimate period the proportional band of the controller (with all integral and derivative action turned off) is gradually reduced until the process cycles continuously.

Experiment steps:

11. Check all the connections for the instrument.
12. Ensure that the water is adequate in the Source tank for experimentation.
13. Ensure that the Bypass Valve is not in closed position.
14. Switch on the Flow loop instrument.
15. Start PID CONTROLLER software in the PC.
16. Click the ‘RECORD’ option provided at the Top right corner of the window in PID Software. Give the file name in which the Data has to be saved.
17. The Controller starts data-logging automatically and starts controlling process based on the preset P,I,D Values.

For ‘PI’ Control:

For controlling the ‘PI’ value, keep the ‘D’ value as ‘0’ (zero)

EXPERIMENT-3:**STUDY OF P+D CONTROL USING PROCESS CONTROL SOFTWARE:****Aim:**

To study the action “**PROPORTIONAL PLUS DERIVATIVE CONTROL**” control for a Temperature process controller using process control software.

Theory:

The team ultimate was attached to this method because its use requires the determination of the ultimate proportional band and ultimate period. The Ultimate proportional band, P_{BU} is the minimum allowable value of proportional band (for a controller with only proportional mode) for which the system continuously oscillating at constant amplitude. The ultimate period (T_u) is the period of response with the proportional band set to its ultimate value. To determine the ultimate proportional band and ultimate period the proportional band of the controller (with all integral and derivative action turned off) is gradually reduced until the process cycles continuously.

Experiment steps:

1. Check all the connections for the instrument.
2. Ensure that the water is adequate in the Source tank for experimentation.
3. Ensure that the Bypass Valve is not in closed position.
4. Switch on the Flow loop instrument.
5. Start PID CONTROLLER software in the PC.
6. Click the ‘RECORD’ option provided at the Top right corner of the window in PID Software. Give the file name in which the Data has to be saved.
7. The Controller starts data-logging automatically and starts controlling process based on the preset P,I,D Values.

For ‘P+D’ Control:

For controlling the ‘PD’ value, keep the ‘I’ value as ‘0’ (zero)

EXPERIMENT-4:**STUDY OF P+I+D CONTROL USING PROCESS CONTROL SOFTWARE:****Aim:**

To study the action “**PROPORTIONAL PLUS INTEGRAL PLUS DERIVATIVE CONTROL**” control for a Flow process controller using process control software.

Theory:

The team ultimate was attached to this method because its use requires the determination of the ultimate proportional band and ultimate period. The Ultimate proportional band, P_{BU} is the minimum allowable value of proportional band (for a controller with only proportional mode) for which the system continuously oscillating at constant amplitude. The ultimate period (T_u) is the period of response with the proportional band set to its ultimate value. To determine the ultimate proportional band and ultimate period the proportional band of the controller (with all integral and derivative action turned off) is gradually reduced until the process cycles continuously.

Experiment steps:

1. Check all the connections for the instrument.
2. Check all the connections for the instrument.
3. Ensure that the water is adequate in the Source tank for experimentation.
4. Ensure that the Bypass Valve is not in closed position.
5. Switch on the Flow loop instrument.
6. Start PID CONTROLLER software in the PC.
7. Click the ‘RECORD’ option provided at the Top right corner of the window in PID Software. Give the file name in which the Data has to be saved.
8. The Controller starts data-logging automatically and starts controlling process based on the preset P,I,D Values.

For ‘PID’ control:

For controlling the ‘PID’ value, SET all the values.

Ultimate (Ziegler and Nicholas) method)**Theory:**

The team ultimate was attached to this method because its use requires the determination of the ultimate proportional band and ultimate period. The Ultimate proportional band, P_{BU} is the minimum allowable value of proportional band (for a controller with only proportional mode) for which the system continuously oscillating at constant amplitude. The ultimate period (T_u) is the period of response with the proportional band set to its ultimate value. To determine the ultimate proportional band and ultimate period the proportional band of the controller (with all integral and derivative action turned off) is gradually reduced until the process cycles continuously.

Experiment steps:

1. Check all the connections for the instrument.
2. Check all the connections for the instrument.
3. Ensure that the water is adequate in the Source tank for experimentation.
4. Ensure that the Bypass Valve is not in closed position.
5. Switch on the Flow loop instrument.
6. Start PID CONTROLLER software in the PC.
7. Click the 'RECORD' option provided at the Top right corner of the window in PID Software. Give the file name in which the Data has to be saved.
8. The Controller starts data-logging automatically and starts controlling process based on the preset P,I,D Values.

a. For 'P' Control:

For controlling the 'P' Value, keep the 'I' and 'D' value '0' (zero).

b. For 'PI' Control:

For controlling the 'PI' value, keep the 'D' value as '0' (zero)

c. For 'PID' control:

For controlling the 'PID' value, SET all the values.

Note: Keep the 'P' value approx around	5.0 to 10.0
Keep the 'I' value approx around	0.0015
Keep the 'D' value approx around	0.0001

Tuning of Controller:

5. Give a step change approx (10%) to the set value and absorb the process response.
6. If the system is over damped reduce the proportional band.
7. If the system is under damped increase the proportional band.
8. Note the proportional band at which the process response just starts continuously cycling with constant amplitude. Note period required for one cycle.

By Ziegler Nicholas method:

Select mode to study and use PID valves from above

Mode	Proportional	Integral	Derivation
P	0.13PBu		
P+I	0.13PBu	0.8Tu	
P+I+D	0.15 PBu	0.5 Tu	0.12Tu

BILL OF MATERIALS FOR FLOW LOOP CONTROL TRAINER:

1. Loop control stand.
2. S.S Tank 250X250X300
3. Air Regulator
4. I to P Converter
5. Control Valve with pneumatic Actuator (1/2")
6. DP Transmitter
7. Pump 1/4PH (Monoblock)
8. Gauge 2.1 KG / cm²
9. Gauge 0 to 100 PSI
10. Orifice.
11. Blue nipples 1/4"
12. Brass 'T' bends 1/2"
13. Brass 'T' bend 1/4"
14. Brass bends 1/2"
15. Adapter 1/2"
16. Nipple 1/2"
17. Nipple 1/2" thread
18. Brass control valve.
19. Toggle switch
20. Power supply cover
21. Water Tube.
22. Stand legs.

Exp-14

14. Measurement And Control Of Level In A Tank Using Capacitive Transducer with SCADA

1. Introduction:

Proportional, Integral, and Derivative controller or PID is a standard feedback loop component in industrial control applications. It measures an "output" of a process and controls an "input", with a goal of maintaining the output at a target value, which is called the "setpoint". An example of a PID application is the control of a process temperature, although it can be used to control any measurable variable which can be affected by manipulating some other process variable.

2. Theory:**PROPORTIONAL BAND**

The control algorithm that generates a linear control output proportional to deviation is called proportional action. In proportional action the amount of change in the measured value (or deviation) is expressed in percent of span that is required to cause the control output to change from 0 to 100% is called the proportional band.

$$P = K_p [SP - PV] + P_0$$

INTEGRAL TIME

With P action the measured value will not necessarily become equal to the set the point, and a deviation will usually be present. The control algorithm that applies changes in output as long as a deviation exists, so as to bring the deviation to zero, is called integral action.

When integral action is used, the parameter that determines how fast the output will change in correspondence to some amount of deviation is referred to as integral time, and shorter the integral time, stronger the integral action (the greater the output rate of change). I action is usually used together with P action as PI action, and due only to I became equal to that due only to P action.

$$P = 1/T_i [SP - PV] + P_0$$

DERIVATIVE TIME:

If the controlled object has a large time constant or dead time, with P or PI action alone there will be cases where the response will be slow, overshoot will occur, and the control system will be unstable. In order to achieve faster response and more stable operation cases one uses derivation action (D action) to apply an output component proportional to the input (deviation) rate of change.

D action must always be used with P action time required with PD action. If a ramp input (constant rate of change input) is applied, for the output due to P action alone to become equal to that due to D action alone. The longer the derivation time the stronger the derivation action.

$$P = T_d \frac{d}{dt} [SP - PV] + P_0$$

SPECIFICATIONS

SENSOR	:	Level Sensor/ Transmitter.
MEASURING TANK	:	Acrylic tank of 30cms length.
MEASURING RANGE	:	30 cms.
WATER PUMP	:	FHP vertical pump
SOURCE TANK	:	SS Tank
EXCITATION	:	5 V DC
CONTROL VALVE	:	½” Globe Valve (Linear) 15mm stem Travel.
ACTUATOR	:	Pneumatic Actuator (input 3-15 PSI)
I to P	:	Input 4-20mA output 3-15PSI
DATA LOGGER	:	16 bit ADC 8 Channel with 12 Bit DAC interfaced with PC through RS-232 Serial port.
CONTROLLER OUTPUT	:	4 – 20mA
POWER	:	230V 50Hz. Power supply to drive the mono-block pump.

SYSTEM CONFIGURATION

1. System Overview:

1) LEVEL LOOP TRAINER

The circuit comprises of three parts:

- a. Air operated Globe valve
- b. Level tank
- c. I/P converter.

2. PROCESS CONTROL SOFTWARE:

Process control software is indigenous software designed using the SCADA (DELTA) software for Level process. The software package for Level control application is very simple and powerful, general purpose which measures the process variable, displays it on the screen.

The software is organized to explain all the control action available for the ON/OFF control, proportional control (P), proportional plus integral control (PI), proportional plus derivative control (PD) and proportional plus integral plus derivative control (P+I+D).

Some of the key features of the software are,

17. User feedable process parameter
18. Facility to store the data being processed as a separate file on the disk which can be used for future analysis.
19. A complete display of the process
20. Display all the graphical parameters both numerically and graphically.
21. Simultaneous graphical display the process variable.
22. Analyze the stored data.
23. Tune the control parameter for PID
24. To perform a historical trend of the process.

2. Overall Panel Block Diagram:

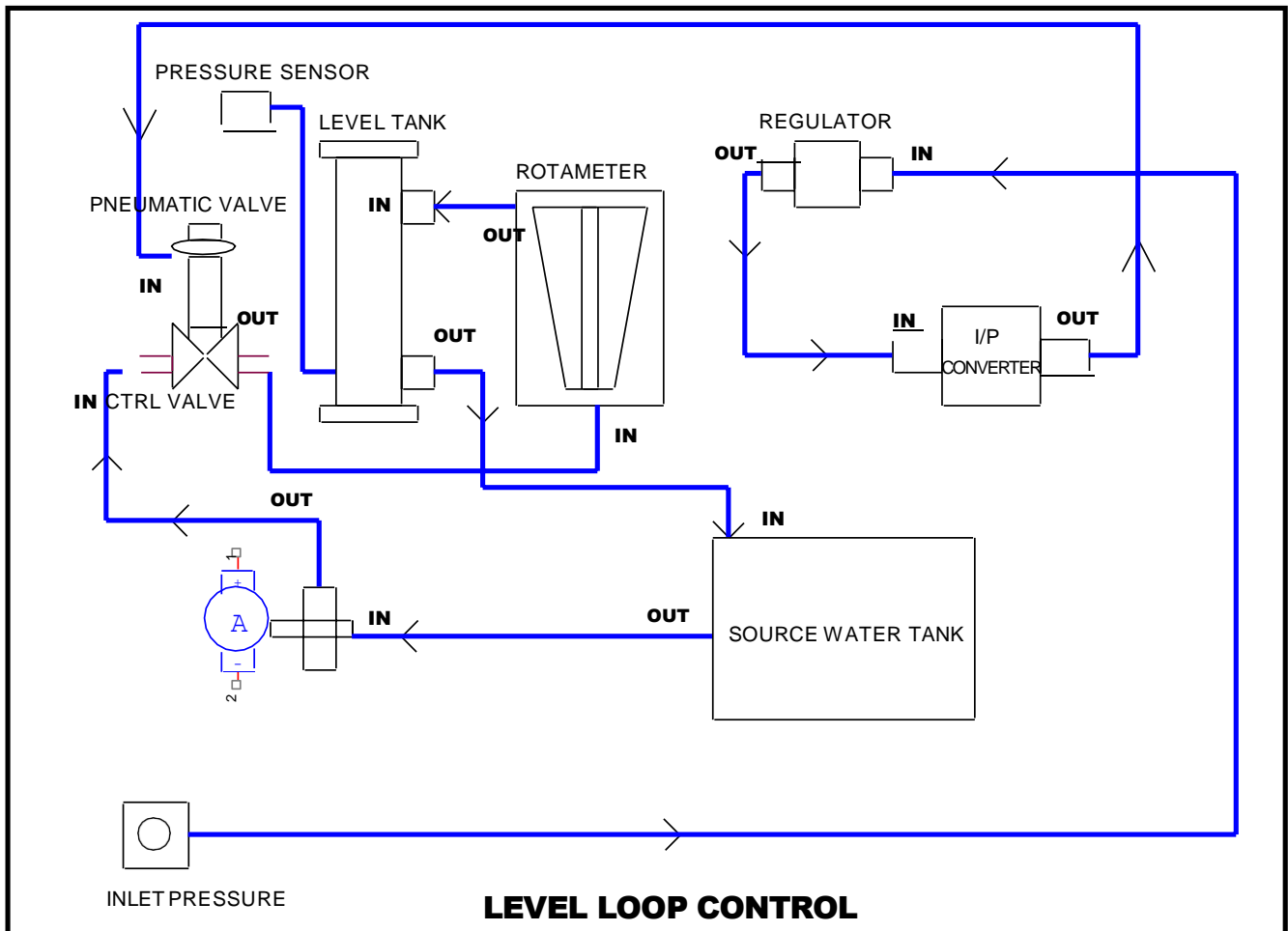

CONNECTION DETAILS:

FOR COMMUNICATION TO PC:

4. Switch ON the power supply of interface card.
5. From the interface card connect the RS-232 comm. port to the PC serial port (com3).

SOFTWARE DETAILS:

This PID software is user friendly software, which is mainly provided for the purpose to analyse, calibrate, monitor, and capture the process loop control data (Level). Through this we can understand the real time applications of the PID process Loop controller respectively. The software is developed using DELTA SCADA software.

EXPERIMENT SECTION FOR LEVEL LOOP CONTROLLER:**EXPERIMENT-1:****STUDY OF PROPORTIONAL CONTROL USING PROCESS CONTROL SOFTWARE:****Aim:**

To study the action “**PROPORTIONAL CONTROL**” control for a Level process controller using process control software.

Theory:

The team ultimate was attached to this method because its use requires the determination of the ultimate proportional band for controller. The Proportional component depends only on the difference between the Set point and the process variable. This difference is referred to as the Error term. The Proportional gain (K_c) determines the ratio of output response to the error signal. Ex. if the error term has a magnitude of 10, a proportional gain of 5 would produce a proportional response of 50. In general increasing the proportional gain will increase the speed of the control system response. But if the Proportional gain is too large, the process variable will begin to oscillate and if increased further the oscillation will become larger and the system will become unstable and may even oscillate out of control. The Ultimate proportional band, P_{Bu} is the minimum allowable value of proportional band (for a controller with only proportional mode) for which the system continuously oscillating at constant amplitude. The ultimate period (T_u) is the period of response with the proportional band set to its ultimate value. To determine the ultimate proportional band and ultimate period the proportional band of the controller (with all integral and derivative action turned off) is gradually reduced until the process cycles continuously.

Experiment steps:

17. Check all the connections for the instrument.
18. Ensure the sufficient water level in the tank, and maintain the level as explained above (in Procedure)
19. Switch ON the Level Loop Trainer Instrument.
20. Switch On the Water Pump.
21. Start PID CONTROLLER software in the PC.
22. Select online when prompted and then enter the file name for which the Datas to be stored.
23. And then click the CONTINUE TEST button option in the Tool bar of the PID Software.
24. The Controller starts data-logging automatically and starts controlling process based on the preset P,I,D Values.

For ‘P’ (Proportional Control):-

For controlling the ‘P’ Value, keep the ‘I’ and ‘D’ value ‘0’ (zero).

EXPERIMENT-2:**STUDY OF P+I CONTROL USING PROCESS CONTROL SOFTWARE:****Aim:**

To study the action “**PROPORTIONAL PLUS INTEGRAL CONTROL**” control for a Level process controller using process control software.

Theory:

The team ultimate was attached to this method because its use requires the determination of the ultimate proportional band and ultimate Integral time for control. The ultimate period (T_u) is the period of response with the proportional band set to its ultimate value. The Ultimate proportional band, P_{Bu} is the minimum allowable value of proportional band (for a controller with only proportional mode) for which the system continuously oscillating at constant amplitude. The integral component sums the error term over time. The result is that even a small error term will cause the integral component to increase slowly. The integral response will continually increase over time unless the error is zero, so the effect is to drive the steady-state error to zero. Steady-State error is the final difference between the process variable and set point. To determine the ultimate proportional band of the controller (with all integral and derivative action turned off) is gradually reduced (K_c) until the process cycles continuously.

Experiment steps:

1. Check all the connections for the instrument.
2. Ensure sufficient water in the tank, and maintain the level as explained above (in Procedure)
3. Switch ON the Level Loop Trainer Instrument.
4. Switch On the Water Pump.
5. Start PID CONTROLLER software in the PC.
6. Select online when prompted and then enter the file name for which the Data to be stored.
7. And then click the CONTINUE TEST button option in the Tool bar of the PID Software.
8. The Controller starts data-logging automatically and starts controlling process based on the preset P,I,D Values.

For ‘PI’ Control:

For controlling the ‘PI’ value, keep the ‘D’ value as ‘0’ (zero)

EXPERIMENT-3:**STUDY OF P+D CONTROL USING PROCESS CONTROL SOFTWARE:****Aim:**

To study the action “**PROPORTIONAL PLUS DERIVATIVE CONTROL**” control for a Level process controller using process control software.

Theory:

The team ultimate was attached to this method because its use requires the determination of the ultimate proportional band and ultimate period. The ultimate period (T_u) is the period of response with the proportional band set to its ultimate value. The derivative component causes the output to decrease if the process variable is increasing rapidly. The derivative response is proportional to the rate of change of the process variable. Increasing the derivative time (T_d) parameter will cause the control system to react more strongly to changes in the error term and will increase the speed of the overall control system response. Most practical control systems use vary small derivative time (T_d), because the Derivative Response is highly sensitive to noise in the process variable signal. If the sensor feedback signal is noisy or if the control loop rate is too slow, the derivative response can make the control system unstable. To determine the ultimate proportional band and ultimate Derivative period of the controller (with Integral action turned off) is gradually reduced until the process cycles continuously.

Experiment steps:

1. Check all the connections for the instrument.

For ‘PI’ Control:

For controlling the ‘PI’ value, keep the ‘D’ value as ‘0’ (zero)

Ensure the sufficient water level in the tank, and maintain the level as explained

above (in Procedure)

3. Switch ON the Level Loop Trainer Instrument.
4. Switch On the Water Pump.
5. Start PID CONTROLLER software in the PC.
6. Select online when prompted and then enter the file name for which the Data to be stored.
7. And then click the CONTINUE TEST button option in the Tool bar of the PID Software.
8. The Controller starts data-logging automatically and starts controlling process based on the preset P,I,D Values.

For ‘P+D’ Control:

For controlling the ‘PD’ value, keep the ‘I’ value as ‘0’ (zero)

EXPERIMENT-4:**STUDY OF P+I+D CONTROL USING PROCESS CONTROL SOFTWARE:****Aim:**

To study the action “**PROPORTIONAL PLUS INTEGRAL PLUS DERIVATIVE CONTROL**” control for a Level process controller using process control software.

Theory:

The team ultimate was attached to this method because its use requires the determination of the ultimate proportional band and ultimate Integral period and ultimate Derivative period for the controller. The gains of a PID controller can be obtained by trial and error method. Once an engineer understands the significance of each gain parameter, this method becomes relatively easy. In this method, the I and D terms are set to zero first and the proportional gain is increased until the output of the loop oscillates. As one increases the proportional gain, the system becomes faster, but care must be taken not make the system unstable. Once P has been set to obtain a desired fast response, the integral term is increased to stop the oscillations. The integral term reduces the steady state error, but increases overshoot. Some amount of overshoot is always necessary for a fast system so that it could respond to changes immediately. The integral term is tweaked to achieve a minimal steady state error. Once the P and I have been set to get the desired fast control system with minimal steady state error, the derivative term is increased until the loop is acceptably quick to its set point. Increasing derivative term decreases overshoot and yields higher gain with stability but would cause the system to be highly sensitive to noise. Often times, engineers need to tradeoff one characteristic of a control system for another to better meet their requirements.

Experiment steps:

1. Check all the connections for the instrument.
2. Ensure the sufficient water level in the tank, and maintain the level as explained above (in Procedure)
3. Switch ON the Level Loop Trainer Instrument.
4. Switch On the Water Pump.
5. Start PID CONTROLLER software in the PC.
6. Select online when prompted and then enter the file name for which the Data to be stored.
7. And then click the CONTINUE TEST button option in the Tool bar of the PID Software.
8. The Controller starts data-logging automatically and starts controlling process based on the preset P,I,D Values.

For ‘PID’ control:

For controlling the ‘PID’ value, SET all the values.

Ultimate (Ziegler and Nicholas) method)**Theory:**

The team ultimate was attached to this method because its use requires the determination of the ultimate proportional band and ultimate period. The Ultimate proportional band, P_{BU} is the minimum allowable value of proportional band (for a controller with only proportional mode) for which the system continuously oscillating at constant amplitude. The ultimate period (T_u) is the

period of response with the proportional band set to its ultimate value. To determine the ultimate proportional band and ultimate period the proportional band of the controller (with all integral and derivative action turned off) is gradually reduced until the process cycles continuously.

Experiment steps:

2. Check all the connections for the instrument.
3. Ensure the sufficient water level in the tank, and maintain the level as explained above (in Procedure)
4. Switch ON the Level Loop Trainer Instrument.
5. Switch On the Water Pump.
6. Start PID CONTROLLER software in the PC.
7. Select online when prompted and then enter the file name for which the Data to be stored.
8. And then click the CONTINUE TEST button option in the Tool bar of the PID Software.
9. The Controller starts data-logging automatically and starts controlling process based on the preset P,I,D Values.

a. For 'P' Control:

For controlling the 'P' Value, keep the 'I' and 'D' value '0' (zero).

b. For 'PI' Control:

For controlling the 'PI' value, keep the 'D' value as '0' (zero)

c. For 'PID' control:

For controlling the 'PID' value, SET all the values.

Note: Keep the 'P' value approx around	100 to 150
Keep the 'I' value approx around	1
Keep the 'D' value approx around	0.2

Tuning of Controller:

9. Give a step change approx (10%) to the set value and absorb the process response.
10. If the system is over damped reduce the proportional band.
11. If the system is under damped increase the proportional band.
12. Note the proportional band at which the process response just starts continuously cycling with constant amplitude. Note period required for one cycle.

By Ziegler Nicholas method:

Mode	Proportional	Integral	Derivation
P	0.13PBu		
P+I	0.13PBu	0.8Tu	
P+I+D	0.15 PBu	0.5 Tu	0.12Tu

Select mode to study and use PID valves from above

BILL OF MATERIALS FOR LEVEL LOOP CONTROL TRAINER:

1. Loop control stand.
2. S.S tank 250X250X300.
3. Control Valve.
4. I/P converter.
5. Regulator.
6. Pump 700-500 LPH.
7. Gauge 2.1 K.G / cm²
8. Gauge (100 PSI).
9. Acrylic Level Tank.
10. Blue Nipple (1/4").
11. Brass 'T' bends (1/4").
12. Brass 'T' bends (1/2").
13. Brass S.S bends (1/2").
14. Brass Nipple (1/4").
15. Brass Nipple (1/2").
16. Releasing Valve (1/4").
17. Adaptor (1/2").
18. Adapter (1/4").
19. 'L' Bends.
20. Water Tube.
21. Blue tube 6mm.
22. Toggle Switch.
23. Power cable.
24. Power supply cover.
25. Stand Legs.

Exp-15

15. Measurement and Control of Pressure Using SCADA System

Objective: To Find out the Pressure Loop using SCADA software of A Given Experiment

Out Come: Will Be Able to Analyze How to Measure the Pressure Loop using the SCADA of a Give Experiment

1. Introduction:

Proportional, Integral, and Derivative controller or PID is a standard feedback loop component in industrial control applications. It measures an "output" of a process and controls an "input", with a goal of maintaining the output at a target value, which is called the "setpoint". An example of a PID application is the control of a process temperature, although it can be used to control any measurable variable which can be affected by manipulating some other process variable.

The Controller compares a measured value from a process (typically and industrial process) are as follows

Industrial processes are procedures involving chemical or mechanical steps to aid in the manufacture of an item or items, usually carried out on a large scale.

Industrial processes are the key components of heavy industry.

Most processes make the production of an otherwise rare material vastly cheaper, thus changing it into a commodity; i.e. the process makes it economically feasible for society to use the material on a large scale. One of the best examples of this is the change in aluminum from prices more expensive than silver to its use in recyclable/disposable beverage containers.

An *industrial process* differs from a craft, workshop or laboratory process by the scale or investment required. Most of the processes are complex and require large capital investments in machinery, or a substantial amount of raw materials, in comparison to batch or craft processes. Production of a specific material may involve more than one type of process.

The difference (or "error" signal) is then used to calculate a new value for a manipulatable input to the process that brings the process' measured value back to its desired setpoint. Unlike simpler control algorithm, the PID controller can adjust process outputs based on the history and rate of change of the error signal, which gives more accurate and stable control. (It can be shown mathematically that a PID loop will produce accurate, stable control in cases where a simple proportional control would either have a steady state error or would cause the process to oscillates). PID controllers do not require advanced mathematics to design and can be easily adjusted (or "tuned") to the desired application, unlike more complicated control algorithms based on optimal control theory.

2. Theory:**PROPORTIONAL BAND**

The control algorithm that generates a linear control output proportional to deviation is called proportional action. In proportional action the amount of change in the measured value (or deviation) is expressed in percent of span that is required to cause the control output to change from 0 to 100% is called the proportional band.

$$P = K_p [SP - PV] + P_0$$

S.NO	Particulars	Specification
01	Pneumatic Valve	1/2 " Globe valve with Pneumatic Actuator
02	Pressure Chamber	MS Air chamber
03	Pressure sensor	Capacity : 5 bar Excitation : 10V O/P : 4-20mA
04	Air Regulator	Input 30 to 100 PSI
05	I/P Converter	Input 30 to 100PSI and 4-20mA Output 3 – 15 PSI
06	Interface Card	16-Bit Data Acquisition card with DAQ o/p (4-20mA) through RS-232 Serial comm. port to PC
07	Interface Controller	PC Based PID Controller developed using LAB VIEW Software.

INTEGRAL TIME

With P action the measured value will not necessarily become equal to the set the point, and a deviation will usually be present. The control algorithm that applies changes in output as long as a deviation exists, so as to bring the deviation to zero, is called integral action.

When integral action is used, the parameter that determines how fast the output will change in correspondence to some amount of deviation is referred to as integral time, and shorter the integral time, stronger the integral action (the greater the output rate of change). I action is usually used together with P action as PI action, and due only to I became equal to that due only to P action.

$$P=1/T_i [SP-PV]$$

DERIVATIVE TIME:

If the controlled object has a large time constant or dead time, with P or PI action alone there will be cases where the response will be slow, overshoot will occur, and the control system will be unstable. In order to achieve faster response and more stable operation cases one uses derivation action (D action) to apply an output component proportional to the input (deviation) rate of change.

D action must always be used with P action time required with PD action. If a ramp input (constant rate of change input) is applied, for the output due to P action alone to become equal to that due to D action alone. The longer the derivation time, the stronger the derivation action.

$$P=T_d \frac{d}{dt} [SP-PV]+P_o$$

SPECIFICATIONS:
SYSTEM CONFIGURATION**1. System Overview:**

The Pressure process controller can be individually classified under four heads namely

- f. The System Overview
- g. Process control Software

The System Overview:

The Overall system is a metallic structure on which a MS metal chamber is mounted in which Pressure has to be maintained. The Air supply is directly connected to the pressure chamber through a ball valve. The other opening of the pressure chamber is connected to a control valve with pneumatic actuator. The output of the I to P converter is connected to Pneumatic actuator which accepts 3 to 15 PSI for opening and closing valve. Since the Control valve is connected to the output of the pressure chamber the control process is reversed. ie. the 20mA of the PID controller is to close the valve and 4mA of the PID controller is for opening of the control valve. The pressure inside the pressure chamber is sensed by a Pressure transmitter which give out 0 to 5V for 0 to 100 PSI pressure. The whole system is mounted on a Table Top, powder coated, MS frame.

PROCESS CONTROL SOFTWARE:

Process control software is indigenous software designed using the LABVIEW software for the pressure process. The software package for pressure control application is very simple and powerful, general purpose which measures the

process variable, displays it on the screen.

The software is organized to explain all the control action available for the ON/OFF control, proportional control (P), proportional plus integral control (PI), proportional plus derivative control (PD) and proportional plus integral plus derivative control (P+I+D).

Note:

Usually proportional integral and derivative control is preferred for Pressure control.

Some of the key features of the software are,

25. User feedable process parameter
26. Facility to store the data being processed as a separate file on the disk which can be used for future analysis.
27. A complete display of the process
28. Display all the graphical parameters both numerically and graphically.
29. Simultaneous graphical display the process variable.
30. Analyze the stored data.
31. Tune the control parameter for PID
32. To perform a historical trend of the process.

2. Overall Panel Block Diagram:

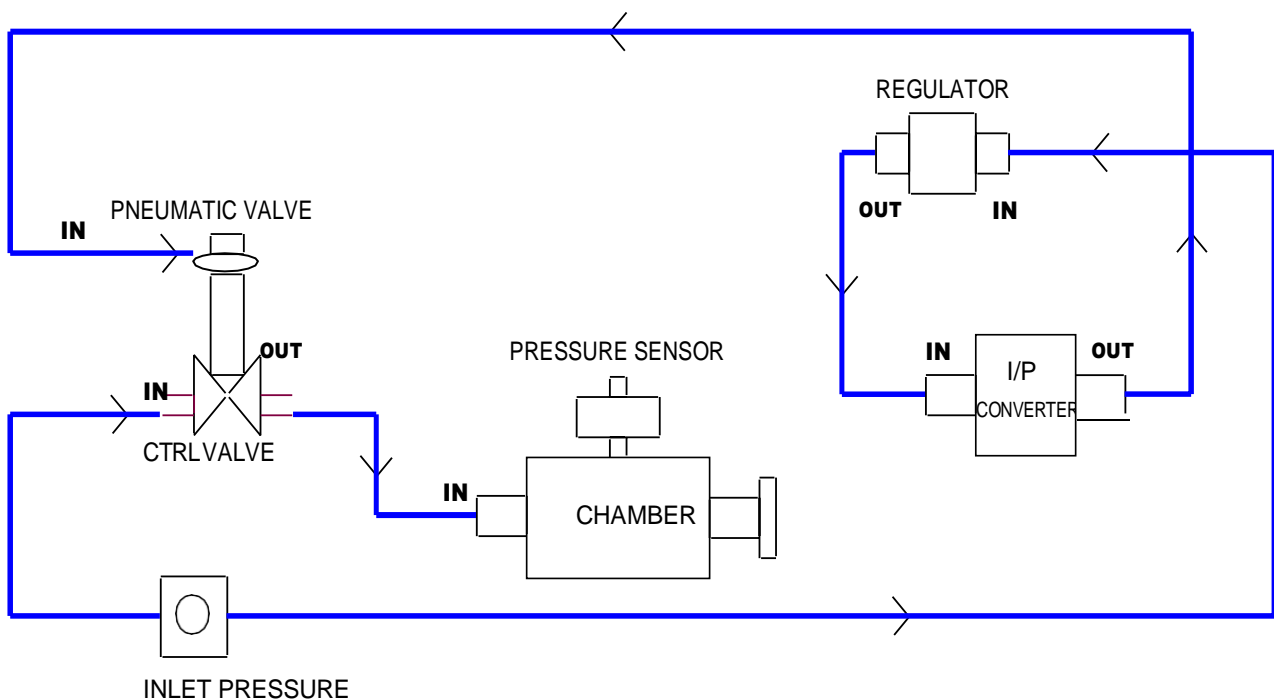

PRESSURE LOOP CONTROL

SYSTEM OPERATION

1. Operating Procedure:

Primary Connection:

6. Connect the power supply 230V / 15A using power socket.
7. Connect the pressure transmitter o/p to the interface unit.
8. Connect the interface unit to RS-232 comm. port to PC.

For Communication to PC:

6. Switch ON the power supply of interface card.
7. From the interface card connect the RS-232 comm. port to the PC serial port (com1 or com2).

EXPERIMENT SECTION FOR PRESSURE LOOP CONTROLLER:

EXPERIMENT-1:

STUDY OF PROPORTIONAL CONTROL USING PROCESS CONTROL SOFTWARE:

Aim:

To study the action “**PROPORTIONAL CONTROL**” control for a Pressure process controller using process control software.

Theory:

The team ultimate was attached to this method because its use requires the determination of the ultimate proportional band and ultimate period. The Ultimate proportional band, P_u is the minimum allowable value of proportional band (for a controller with only proportional mode) for which the system continuously oscillating at constant amplitude. The ultimate period (T_u) is the period of response with the proportional band set to its ultimate value. To determine the ultimate proportional band and ultimate period the proportional band of the controller (with all integral and derivative action turned off) is gradually reduced until the process cycles continuously.

Experiment steps:

25. Check all the connections for the instrument.
26. Ensure that the Pressure in the compressor is above 5 bar.
27. Switch ON the Pressure Loop Trainer Instrument.
28. Open the Ball valve little so that the air starts filling the Pressure chamber.
29. Start PID CONTROLLER software in the PC.
30. Select online when prompted and then enter the file name for which the Datas to be stored.
31. And then click the CONTINUE TEST button option in the Tool bar of the PID Software.
32. The Controller starts data-logging automatically and starts controlling process based on the preset P,I,D values.

For ‘P’ (Proportional Control):-

For controlling the ‘P’ Value, keep the ‘I’ and ‘D’ value ‘0’ (zero).

STUDY OF P+I CONTROL USING PROCESS CONTROL SOFTWARE:**Aim:**

To study the action “**PROPORTIONAL PLUS INTEGRAL CONTROL**” control for a Pressure process controller using process control software.

Theory:

The team ultimate was attached to this method because its use requires the determination of the ultimate proportional band and ultimate period. The Ultimate proportional band, P_{BU} is the minimum allowable value of proportional band (for a controller with only proportional mode) for which the system continuously oscillating at constant amplitude. The ultimate period (T_u) is the period of response with the proportional band set to its ultimate value. To determine the ultimate proportional band and ultimate period the proportional band of the controller (with all integral and derivative action turned off) is gradually reduced until the process cycles continuously.

Experiment steps:

18. Check all the connections for the instrument.
19. Ensure the Air compressor pressure is maintained above 5Kg/cm² in the tank is adequate.
20. Start the Pressure Loop Trainer Instrument.
21. Open the Ball valve little so that the air starts filling the Pressure tank.
22. Start PID CONTROLLER software in the PC.
23. Select online prompted and then enter the file name for which the Datas to be stored.
24. And then click the CONTINUE TEST option in the Tool bar of the PID Software.
25. The Controller starts data-logging automatically and starts controlling process based on the preset P,I,D Values.

For 'PI' Control:

For controlling the 'PI' value, keep the 'D' value as '0' (zero)

EXPERIMENT-3:**STUDY OF P+D CONTROL USING PROCESS CONTROL SOFTWARE:****Aim:**

To study the action “**PROPORTIONAL PLUS DERIVATIVE CONTROL**” control for a pressure process controller using process control software.

Theory:

The team ultimate was attached to this method because its use requires the determination of the ultimate proportional band and ultimate period. The Ultimate proportional band, P_{BU} is the minimum allowable value of proportional band (for a controller with only proportional mode) for which the system continuously oscillating at constant amplitude. The ultimate period (T_u) is the period of response with the proportional band set to its ultimate value. To determine the ultimate proportional band and ultimate period the proportional band of the controller (with all integral and derivative action turned off) is gradually reduced until the process cycles continuously.

Experiment steps:

11. Check all the connections for the instrument.
12. Ensure the Air compressor pressure is maintained above 5Kg/cm² in the tank is adequate.
13. Start the Pressure Loop Trainer Instrument.
14. Open the Ball valve little so that the air starts filling the Pressure tank.
15. Start PID CONTROLLER software in the PC.
16. Select online prompted and then enter the file name for which the Datas to be stored.
17. And then click the CONTINUE TEST option in the Tool bar of the PID Software.
18. The Controller starts data-logging automatically and starts controlling process based on the preset P,I,D Values.

For ‘P+D’ Control:

For controlling the ‘PD’ value, keep the ‘I’ value as ‘0’ (zero)

EXPERIMENT-4:**STUDY OF P+I+D CONTROL USING PROCESS CONTROL SOFTWARE:****Aim:**

To study the action “**PROPORTIONAL PLUS INTEGRAL PLUS DERIVATIVE CONTROL**” control for a Pressure process controller using process control software.

Theory:

The team ultimate was attached to this method because its use requires the determination of the ultimate proportional band and ultimate period. The Ultimate proportional band, P_{BU} is the minimum allowable value of proportional band (for a controller with only proportional mode) for which the system continuously oscillating at constant amplitude. The ultimate period (T_u) is the period of response with the proportional band set to its ultimate value. To determine the ultimate proportional band and ultimate period the proportional band of the controller (with all integral and derivative action turned off) is gradually reduced until the process cycles continuously.

Experiment steps:

11. Check all the connections for the instrument.
12. Ensure the Air compressor pressure is maintained above 5Kg/cm² in the tank is adequate.
13. Start the Pressure Loop Trainer Instrument.
14. Open the Ball valve little so that the air starts filling the Pressure tank.
15. Start PID CONTROLLER software in the PC.
16. Select online prompted and then enter the file name for which the Datas to be stored.
17. And then click the CONTINUE TEST option in the Tool bar of the PID Software.
18. The Controller starts data-logging automatically and starts controlling process based on the preset P,I,D Values.

For ‘PID’ control:

For controlling the ‘PID’ value, SET all the values.

Ultimate (Ziegler and Nicholas) method)**Theory:**

The team ultimate was attached to this method because its use requires the determination of the ultimate proportional band and ultimate period. The Ultimate proportional band, P_{BU} is the minimum allowable value of proportional band (for a controller with only proportional mode) for which the system continuously oscillating at constant amplitude. The ultimate period (T_u) is the period of response with the proportional band set to its ultimate value. To determine the ultimate proportional band and ultimate period the proportional band of the controller (with all integral and derivative action turned off) is gradually reduced until the process cycles continuously.

Experiment steps:

- Start the Pressure Loop Trainer Instrument.
- Ensure the Air compressor pressure is maintained above 5Kg/cm^2 in the tank is adequate.
- Start the Pressure Loop Trainer Instrument.
- Open the Ball valve little so that the air starts filling the Pressure tank.
- Start PID CONTROLLER software in the PC.
- Select online prompted and then enter the file name for which the Datas to be stored.
- And then click the CINTINUE TEST in the Tool bar of the PID software.
- The Controller starts data-logging automatically and starts controlling process based on the preset P,I,D Values.

a. For 'P' Control:

For controlling the 'P' Value, keep the 'I' and 'D' value '0' (zero).

b. For 'PI' Control:

For controlling the 'PI' value, keep the 'D' value as '0' (zero)

c. For 'PID' control:

For controlling the 'PID' value, SET all the values.

Note: Keep the 'P' value approx around	100 to 150
Keep the 'I' value approx around	1
Keep the 'D' value approx around	0.2

Tuning of Controller:

13. Give a step change approx (10%) to the set value and absorb the process response.
14. If the system is over damped reduce the proportional band.
15. If the system is under damped increase the proportional band.
16. Note the proportional band at which the process response just starts continuously cycling with constant amplitude. Note period required for one cycle.

By Ziegler Nicholas method:

Mode	Proportional	Integral	Derivation
P	2PBu		
P+I	2.2PBu	Tu/1.2	
P+D	1.65PBu		Tu / 8.0
P+I+D	1.65 PBu	0.5 Tu	Tu / 8.0

Select mode to study and use PID valves from above

BILL OF MATERIALS FOR PRESSURE LOOP CONTROL TRAINER:

1. Loop Control stand.
2. Legs
3. Control valve ½” with Pneumatic Actuator.
4. I/P converter
5. Pressure Regulator
6. Pressure Transmitter (0 -5kg/cm²)
7. Pressure chamber
8. Gauge 2.1 Kg / cm²
9. Gauge 0 to 100 PSI
10. ¼” Ball Valve
11. Blue nipples ½”
12. Brass ‘T’ bends ¼”
13. Brass adapter ¼”
14. Pressure sensor
15. Blue tube.

Exp: 4 Viva Questions

1. What are the different types of strain gauges?
2. What is the principle of mechanical torsion meter
3. How do you measure strain?
4. What is gauge factor of strain gauge?
5. How does a Wheatstone bridge strain gauge work?
6. Bonding element in a strain gauge must have _____
7. Dynamic strain measurements use _____
8. Explain the working of a bourdon tube pressure gauge.
9. Electrical strain gauge works on the principle of _____
10. What is systematic error?
11. What is strain gauge load cell?
12. Gauge factor in a strain gauge must be _____
13. Strain gauges are used for _____
14. How do you calculate gauges?
15. Resistance of the strain gauge must be _____
16. What is bonded strain gauge?
17. Define the term calibration.
18. What is the working principle of strain gauge?
19. What is meant by primary calibration?
20. List two deflection type instruments.
21. What is a power operated instrument?
22. Define force
23. List the various measurement methods and explain them.
24. Draw the block diagram of a generalized measurement system
25. Briefly explain the applications of measuring instruments.
26. Commonly used elements for wire strain gauges are _____
27. Classify various errors and explain them in detail.
28. Explain how strain gauges are calibrated.
29. Discuss on calibration, error and correction curves.
30. What is gauge rosette?
31. List the materials used for fine wire strain gauges
32. Commonly used electrical strain gauge is _____
33. What is piezo-resistivity?
34. Resistance wire gauges come in _____
35. Define humidity
36. Define dry air
37. Strain gauges are classified into _____
38. What is moist air?
39. Bonded resistance wire strain gauge is of _____
40. Proper bonding causes errors in strain gauges.
41. Mechanical gauges measure the _____
42. Cement is classified under _____
43. Gauge factor is given by the relation _____
44. Define resistance strain gauge?
45. How do you calibrate a strain gauge?
46. What is a strain gauge amplifier?
47. What does strain gauge measure?
48. What is strain explain?
49. How does needle size affect gauge?
50. What is foil type strain gauge?

Exp-5 Viva Questions

1. Define the term transducer.
2. What is meant by loading?
3. What is a thermocouple?
4. State two limitations of a total radiation pyrometer.
5. Differentiate atmospheric pressure and absolute pressure.
6. List two instruments used to measure low pressure.
7. What are the limitations of thermistor?
8. Explain the basic principle on which the bimetallic thermometer works.
9. List the common metals used in bimetallic strips.
10. What are pyrometers?
11. Define temperature.
12. List three areas where temperature measurement is important.
13. State the basic principle behind a resistance potentiometer.
14. What is a pressure thermometer?
15. List various transducers used for displacement measurement.
16. Differentiate gauge pressure and vacuum pressure.
17. What is an electric transducer?
18. Differentiate analog and digital transducers.
19. What is an elastic transducer?
20. List a few applications of pressure measurement.
21. Explain the calibration procedure for inductive transducer.
22. Design a measurement system for displacement measurement using LDR (Light dependent resistor) as sensor.
23. Explain the temperature measurement by thermocouples
24. How do you measure the pressure with the help of U-tube manometer and micro-manometer?
25. What is J type thermocouple?
26. How is thermocouple voltage measured?
27. Differentiate between rare metal thermocouples and base metal thermocouples
28. Explain the construction and working of a photo-electric transducer.
29. What is a hot junction?
30. List electrical transducers for measurement of linear and angular displacement.
31. What color is type K thermocouple wire?
32. How cold junction compensation is done in thermocouple?
33. What is cold junction in thermocouple?
34. How accurate is a thermocouple?
35. Why do thermocouples have two metals?
36. Define calibrate a thermocouple?
37. What color is type K thermocouple wire?
38. What causes a thermocouple to fail?
39. Compare a primary transducer with secondary transducer.
40. Explain absolute, gauge and vacuum pressure
41. Describe the construction, theory and applications of different types of Diaphragm pressure gauges.
42. Give examples for active and passive transducers.
43. Why do thermocouples need to be connected with special wire?
44. How is thermocouple voltage measured?
45. Differentiate atmospheric pressure and absolute pressure
46. Differentiate analog and digital transducers.
47. What is reference junction thermocouple?
48. How does a type J thermocouple work?
49. Explain the construction and working principle of Ionization pressure gauge.
50. What is a thermopile?

Exp- 6 Viva Questions

1. How does capacitive displacement sensor work?
2. What is the basic principle of capacitive transducer?
3. Define the term transducer.
4. What is meant by loading?
5. Compare a primary transducer with secondary transducer.
6. Give examples for active and passive transducers.
7. How does a displacement sensor work?
8. What is an elastic transducer?
9. Differentiate analog and digital transducers.
10. What is the function of transducer?
11. What is an electric transducer?
12. What is a mechanical transducer?
13. What is capacitive pressure sensor?
14. What is meant by displacement measurement?
15. List various transducers used for displacement measurement.
16. State the basic principle behind a resistance potentiometer.
17. How does a soil moisture sensor work?
18. List three areas where temperature measurement is important.
19. Define temperature.
20. Explain the basic principle on which the bimetallic thermometer works.
21. What is transducer and its types?
22. List the common metals used in bimetallic strips.
23. What is a pressure thermometer?
24. What are the limitations of thermistor?
25. What is resistive transducer?
26. State two limitations of a total radiation pyrometer.
27. What is meant by inductive transducer?
28. Differentiate atmospheric pressure and absolute pressure.
29. What is transducer give example?
30. Differentiate gauge pressure and vacuum pressure.
31. What are pyrometers?
32. List a few applications of pressure measurement.
33. What is the working principle of transducer?
34. List two instruments used to measure low pressure.
35. What is a thermocouple?
36. Define Piezo-electric
37. Explain speaker a transducer?
38. Define Capacitance
39. Define Ionization
40. Distinguish between RTD and Thermistor
41. How does LVDT measure displacement?
42. Explain absolute, gauge and vacuum pressure
43. State and explain the three laws of thermocouples.
44. What is a thermopile?
45. Explain the working of a total radiation pyrometer.
46. How an elastic diaphragm gauge is used to measure pressure?
47. Explain the bellows gauge used to measure gauge pressure.
48. How can a strain gauge be used to measure pressure?
49. What do capacitive sensors detect?
50. How does a capacitive soil moisture sensor work?

Exp- 7 VIVA QUESTIONS

1. Define Vibration
2. What is piezo – electric effect?
3. State any three mechanical tachometers used to measure angular velocity
4. Write the list of various contactless electrical tachometers
5. Write any three measurement devices for measurement of linear velocity
6. Define strain
7. What is bonded strain gauge?
8. What is self temperature compensation?
9. Write various instruments which are used for measuring vibrations
10. State the basic principle behind tachogenerators
11. What is gauge rosette?
12. List the materials used for fine wire strain gauges
13. Define strain gauge
14. What is piezo-resistivity?
15. What is gauge factor?
16. Define humidity
17. What is moist air?
18. What is Poisson's ratio?
19. Define saturated air
20. State the basic principle on which a seismic displacement sensing accelerometer works
21. What is absolute humidity?
22. Define dry air
23. What is relative humidity?
24. Define humidity ratio
25. What is the principle of mechanical torsion meter
26. What is wet bulb depression?
27. Define dew point temperature
28. Write two examples for closed-loop control system
29. What is percentage humidity?
30. State the basic principle on which a strain gauge accelerometer works
31. Define humidity ratio
32. What is the principle of optical torsion meter
33. Define photo-electric transducer.
34. How does a transducer work?
35. What is the principle of optical torsion meter
36. What are electrical transducers?
37. Define LDR and its function?
38. What is meant by LVDT?
39. Why are transducers important?
40. Define power
41. How is LDR measured?
42. What is pressure transducer used for?
43. What is photoconductivity physics?
44. Classification of photo electric transducer?
45. What is the principle of mechanical torsion meter
46. What is photoconductive transducer?
47. What is the principle of electrical torsion meter
48. Define torque
49. Define force
50. What is meant by measurement?

Exp- 8 VIVA QUESTIONS

1. Commonly used elements for wire strain gauges are _____
2. Classify various errors and explain them in detail.
3. Explain how strain gauges are calibrated.
4. Discuss on calibration, error and correction curves.
5. What is gauge rosette?
6. List the materials used for fine wire strain gauges
7. Commonly used electrical strain gauge is _____
8. What is piezo-resistivity?
9. Resistance wire gauges come in _____
10. Define humidity
11. Define dry air
12. Strain gauges are classified into _____
13. What is moist air?
14. What is an electric transducer?
15. List various transducers used for displacement measurement.
16. State two limitations of a total radiation pyrometer.
17. Define temperature.
18. How does pt100 RTD work?
19. What are mechanical instruments?
20. What is RTD
21. What is a thermopile?
22. how it works RTD
23. What is difference between pt100 and RTD?
24. Define applications for RTD?
25. What is a pressure thermometer?
26. How many types of RTD are there?
27. List two deflection type instruments.
28. What is RTD wire?
29. What is the difference between an RTD and a thermostat?
30. What is a power operated instrument?
31. Explain the elements of control system
32. How control systems are classified?
33. Explain four examples of control system applications
34. Define Block diagram
35. Define system error
36. What is percentage humidity?
37. Explain open-loop control system
38. Explain the block diagram of the feedback control system
39. Differentiate the terms 'accuracy' and 'precision'.
40. Define reference input
41. Explain briefly two examples of open-loop control systems
42. What is a pressure thermometer?
43. Define actuating signal
44. Differentiate between pneumatic and hydraulic control systems
45. What is chaotic error?
46. What is a mechanical transducer?
47. What are the limitations of thermistor?
48. Define disturbance
49. Enumerate the deficiencies of Routh's criterion
50. Explain Routh stability criterion

EXP-9 VIVA QUESTIONS

1. What is liquid level?
2. Why flow measurement is important?
3. What are secondary or rate meters?
4. Write the two kinds of velocity
5. State any one linear velocity transducer
6. Write the principle of working of a magnetic flow meter?
7. Describe the construction of bubbler level indicator
8. Explain the use of rota meter for flow measurement.
9. How can gamma rays be used to measure liquid level?
10. Define Hook level indicator
11. Describe the working of a rota meter.
12. Explain in Bubbler level indicator
13. How rate flow is measured using a pitot tube?
14. Explain the working of a magnetic flow meter
15. Explain the working principle of ultrasonic flow meter
16. How many types of rota meter are there?
17. Why flow meter is used?
18. Explain any one float operated liquid level gauge.
19. Explain in Ultrasonic level method
20. What is an electric transducer?
21. How does rota meter usually get damaged?
22. Explain a device using a float – rheostat to measure liquid level.
23. Define humidity ratio
24. Define Turbine flow meter
25. What is the application of rota meter?
26. How is a venture flow meter used to measure flow?
27. Explain the construction and working of a flow nozzle.
28. What is the difference between flow meter and flow transmitter?
29. How does a flow meter work?
30. Explain the basic principle behind electric liquid level sensors.
31. Define strain
32. What is bonded strain gauge?
33. What is gauge factor?
34. What is gauge rosette?
35. Explain in Capacitive level method
36. What is self temperature compensation?
37. Define humidity
38. Explain a capacitive liquid level sensor used to measure liquid level.
39. What is piezo-resistivity?
40. On what basic principle does an obstruction meter work?
41. Define Cryogenic fuel method
42. What is Poisson's ratio?
43. Define strain gauge
44. Explain the construction and working of an orifice meter.
45. Where are magnetic flow meters used?
46. List the materials used for fine wire strain gauges
47. Explain any one purge system to measure liquid level.
48. What is an ultrasonic flow meter?
49. Define Velocity
50. What is the difference between direct and indirect liquid level measuring devices?

Exp- 10 Viva Questions

1. Define Vibration
2. Explain Inductive pickup and stroboscope tachometer
3. List the specifications of vibration exciter?
4. Define mounting vibration sensor?
5. Explain controls of vibrations analyzer?
6. Write any three measurement devices for measurement of linear velocity
7. Difference between controls of oscillator and power amplifier?
8. Define oscillator?
9. Explain centrifugal tachometer
10. State any three mechanical tachometers used to measure angular velocity
11. Define accelerometer
12. What are the units for frequency?
13. Define DC and AC Tachogenerator
14. What is calibration accuracy?
15. Explain with working of slipping clutch?
16. Difference between calibration & validation?
17. What is calibration of instrument?
18. What is balance calibration?
19. How is calibration done?
20. State the basic principle behind tachogenerators.
21. What is calibration and its types?
22. What is servomechanism?
23. Write various instruments which are used for measuring vibrations
24. What is synchro?
25. What do you meant by vibration?
26. Define closed loop control system.
27. Explain absolute gauge and vacuum pressure
28. What is frequency?
29. Define open loop control system.
30. Write the list of various contactless electrical tachometers
31. What are the two major types of control system?
32. State the basic principle on which a strain gauge accelerometer works
33. What are the components of feedback control system?
34. What is control system?
35. Define transfer function.
36. What is a seismic wave.
37. Explain commutated capacitor tachometer
38. What are the basic elements used for modeling mechanical translational system?
39. How do you identify resistor color codes?
40. What is piezo – electric effect?
41. What are the types of validation?
42. How do you calculate tolerance?
43. Name two types of electrical analogous for mechanical system.
44. Define photo electric and capacitor tachometer
45. What is block diagram?
46. What are the principles of calibration?
47. What is a signal flow graph?
48. What is the difference between an RTD and a thermostat?
49. What are the advantages of piezoelectric transducer?
50. Explain working of vibrating reed and drag cup tachometer?

Exp-11 Viva Questions

1. What is the use of pressure gauge?
2. What is the principle of McLeod gauge?
3. Explain the McLeod gauge
4. Applications of McLeod gauge
5. How does a thermocouple vacuum gauge work?
6. What is a Torr gauge?
7. Write the elements of a control system
8. Define an indirectly controlled variable
9. Write the classification of control systems
10. Define strain
11. Define a controlled variable
12. Write the elements of open-loop control system
13. What is wet bulb depression?
14. Sketch the open-loop control system
15. Define system error
16. What is angularity error?
17. Define torque
18. Define power
19. Define open-loop control system.
20. What is the principle of mechanical torsion meter
21. Define strain gauge
22. What is meant by loading?
23. Define the term transducer
24. What are the advantages of pressure gauge?
25. State the basic principle behind a resistance potentiometer.
26. List the common metals used in bimetallic strips
27. How do you measure vacuum McLeod gauge?
28. Define limitations of McLeod gauge?
29. Define dry air
30. What is the multiplication error?
31. Define saturated air
32. What is moist air?
33. Explain in Bubbler level indicator
34. What are the objectives of control?
35. What are the disadvantages of pressure gauge?
36. Define control techniques?
37. Differentiate gauge pressure and vacuum pressure.
38. What are types of control system?
39. What is meant by measurement?
40. Give two examples for primary measurement.
41. What are pressure gauge units?
42. What is the zero order error?
43. Define errors of pressure gauge
44. What is a primary sensing element?
45. Differentiate the terms 'accuracy' and 'precision'
46. What is a vacuum gauge called?
47. What is loading error?
48. How does a Penning gauge work?
49. What is absolute humidity?
50. What are the limitations of pressure gauge?

Exp-12 VIVA QUESTIONS

1. Define SCADA
2. What is Scada and how does it work?
3. What are the components of SCADA?
4. Applications of SCADA.
5. What are the units for frequency?
6. What Is Plc?
7. What is CMS?
8. Define end systolic pressure volume?
9. List two deflection type instruments
10. What is meant by PLC and Scada?
11. Define a level loop?
12. What is a power operated instrument?
13. What is Programmable Logic Controllers
14. What is an electric transducer?
15. List two instruments used to measure low pressure.
16. Define PID
17. Define Velocity
18. Explain the 3 types of loops?
19. What are the applications of PLC?
20. What is a Scada server?
21. What is piezo – electric effect?
22. Define the term transducer
23. Applications Of Plc?
24. Write the two kinds of velocity
25. What is a control loop in instrumentation?
26. Explain what are different components in PLC?
27. Define pressure
28. What is Data Acquisition? .
29. Differentiate the terms ‘accuracy’ and ‘precision’.
30. What is the difference between PLC and Scada?
31. What is the principle of RTD?
32. What is calibration?
33. How RTD used for Temperature measurement
34. What are the advantages RTD?
35. What is the replacement for temperature measurement ?
36. What is the principle of Thermocouple?
37. What is calibration?
38. How Thermocouple used for Temperature measurement and what is the range of thermocouples?
39. What are the advantages of Thermocouple
40. What is the principle of Thermistor?
41. What is calibration?
42. How Thermistor used for Temperature measurement?
43. What are the advantages of Thermistor?
44. What is the replacement for temperature measurement if Thermistor is not there?
45. Define saturated air
46. What is systematic error?
47. Define Loop level and types?
48. What is a flow control loop?
49. How do you measure strain?
50. Define temperature.

